

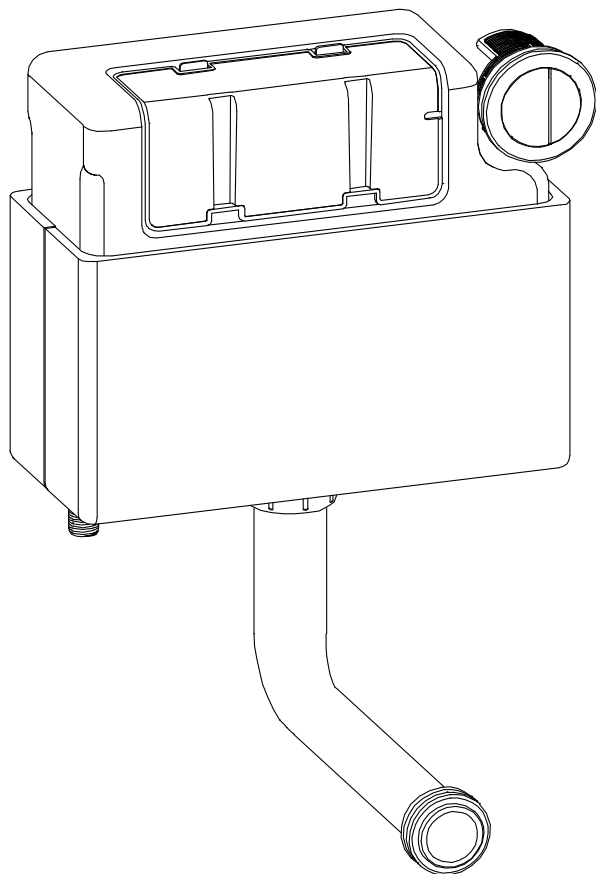

Concealed Cistern



Fitting Instructions

Please follow them carefully and
leave this manual with end user

Before you begin:

1. **We recommend that this product is installed by a qualified tradesperson.** Victorian Plumbing Ltd. accept no liability for products incorrectly installed, or where the correct testing procedures have not been adhered to, thus resulting in the escape of water and consequential damage.
2. **Check the chosen wall space for any pipes/cables prior to drilling the wall.**
3. Ensure the incoming mains water supply is switched off prior to commencing the installation.
4. Observe all local plumbing and building codes & regulations.
5. Unpack the product then read these instructions before proceeding. Inspect the product for damage. If any damage is found, contact our Customer Relations team.

Parts:

Fixing components:

1. Flush Valve (x1)
2. Fill Valve (x1)
3. Tank (x1)
4. Seal (x1)
5. Plastic Washer (x1)
6. Flush Connection Nut (x1)
7. Flush Connection Pipe (x1)
8. Gasket (x1)
9. Push Button (x1)
10. Screw (x2)

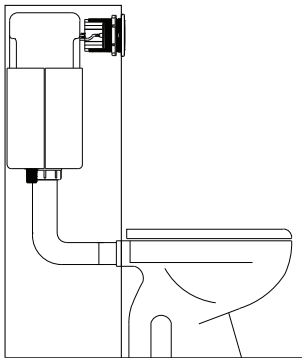
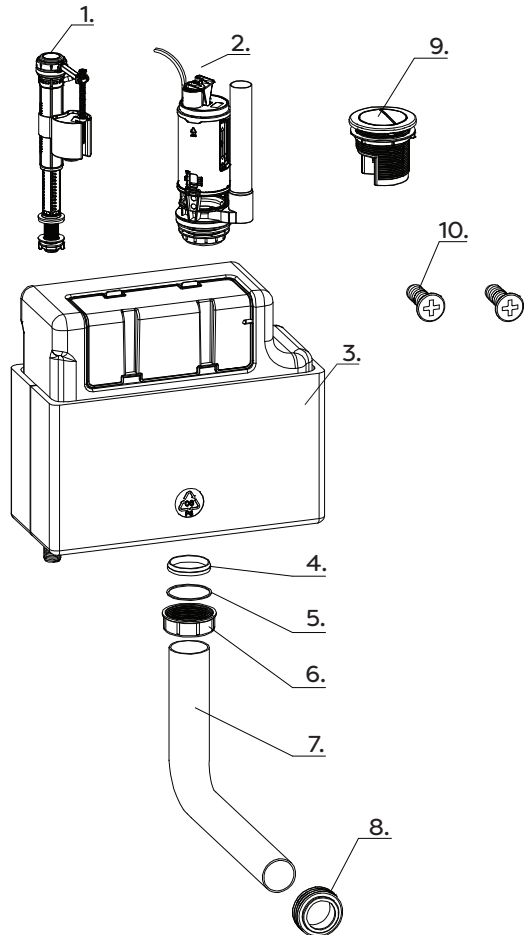

Diagrams are for illustration purposes only. Your cistern may superficially differ from these drawings however the installation guide steps still apply.

Tools required for installation (not supplied)



Pencil

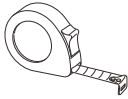

Tape Measure



Drill



Screw Driver



Spirit Level



Adjustable Wrench



Silicone Sealant

Cleaning

To maintain the surface finish of your product, wipe the toilet regularly using a clean damp cloth, a mild detergent mixture can be used. Do not use abrasive cleaning agents or materials which can strip and scratch the surface.

Fitting Installation

Diagrams are for illustration purposes only. Your cistern may superficially differ from these drawings however the installation guide steps still apply.

Fill Valve:

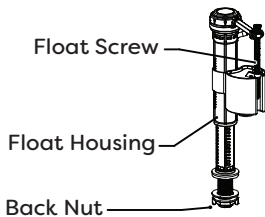

Flush Valve:

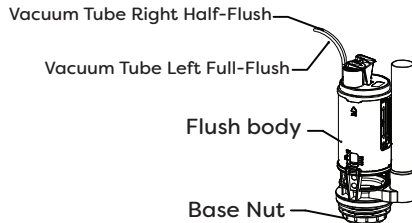

(Note: Flush valve may be colour coded indicating Half and Full flush)

Water level and fill valve maintenance

- To get the best flush performance while saving water at the same time, you may need to adjust the fill valve level.
- As shown in Below Illustration, Screw the float screw with a Cross/Phillips screwdriver to move the float up and down to achieve the appropriate water level in the tank. Turning the float screw anti-clockwise (A) will lower the water level, and turning the float screw clockwise (B) will increase the water level.

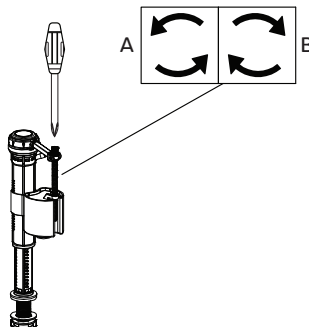

Step 1:

- Insert the fill valve into the cistern tank. Secure the fill valve in place by screwing the back nut to the underside of the cistern.

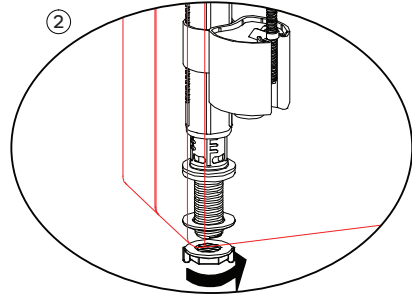
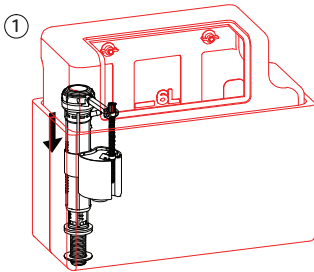

Step 2:

- Insert the flush valve down into the flush pipe hole, then secure into place by screwing the base nut to the underside of the cistern flush hole.

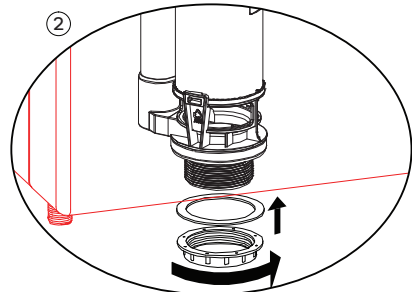
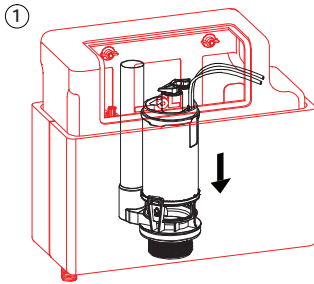

Step 3:

- Connect the flush connection pipe to the under side of the flush valve. Screw the flush connection nut to the pipe to secure it in place.

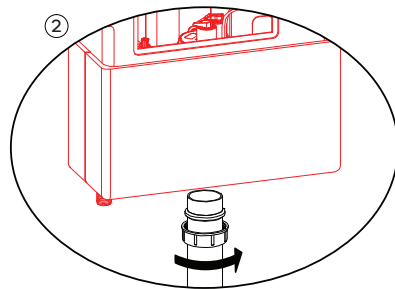
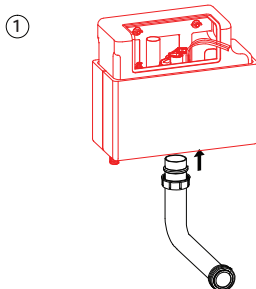

Installation

Step 1:

- Unscrew the plastic caps inside the back of the cistern to release the mounting bracket (be careful not to lose the plastic hex screws). Position the mounting bracket within the appropriately sized cabinet at the correct height, and mark the holes ready for drilling.

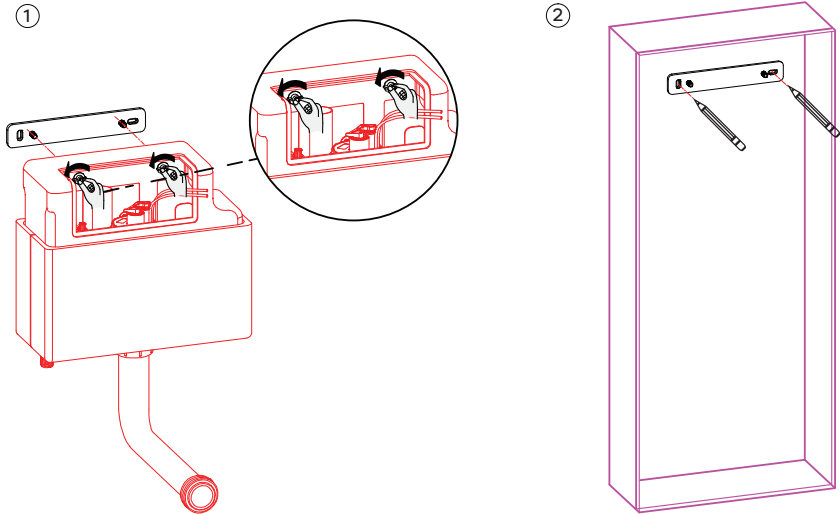

Step 2:

- Using an appropriately sized drill bit carefully drill the cabinet. Fix the mounting bracket to the cabinet using the screws provided.

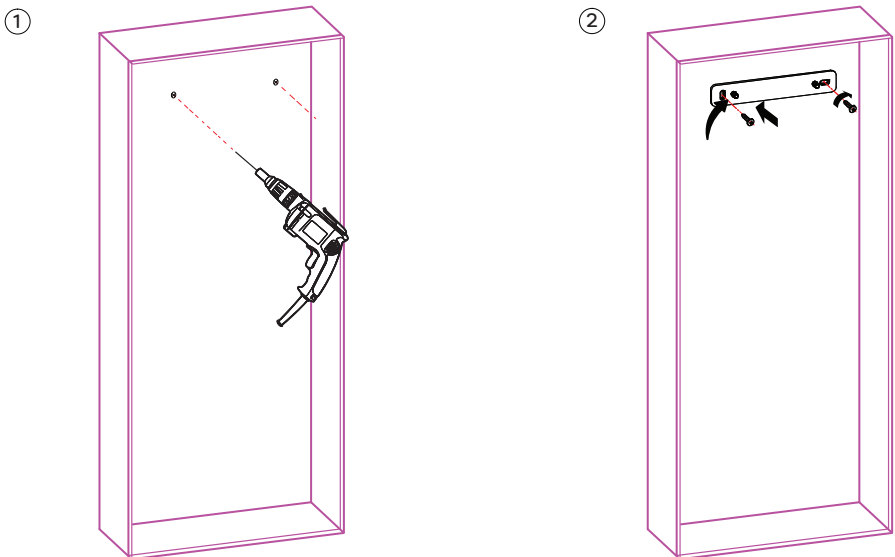

Step 3:

- Mount the cistern back onto the bracket and screw the plastic caps to the plastic threads. (Ensure that the cistern is securely fixed to the cabinet.) Clip the cover plate into position with the vacuum pipes threaded through the hole ready for connection.
- Connect the inlet pipe to the threaded tail of the fill valve on the underside of the cistern.

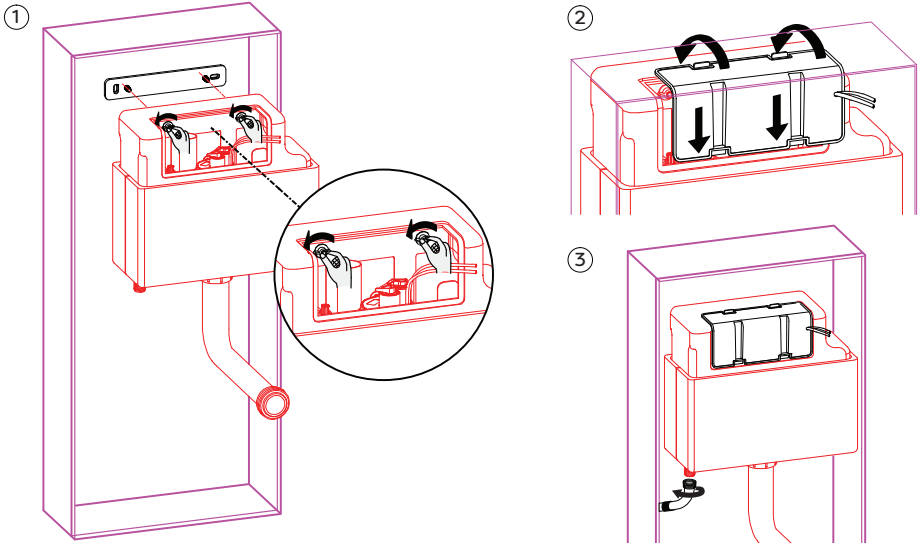

Step 4:

- Unscrew the back nut from the flush button, then place the flush button into the pre-drilled hole in the cabinet door (make sure the hole is the correct size for the flush button). Secure into place with the back nut.
- Connect the vacuum tubes to the back of the flush button, ensuring that the tubes are connected to the correct push button.

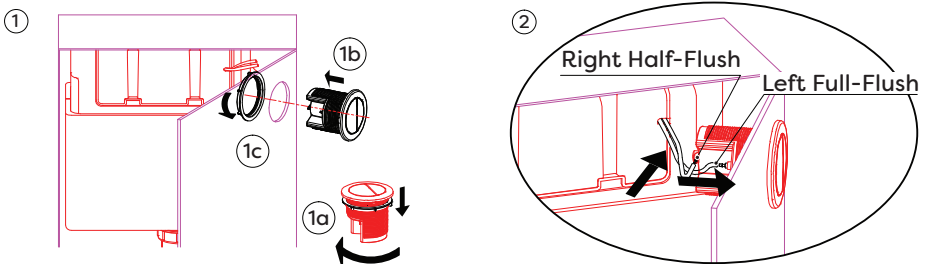

Step 5:

- Prepare the cabinet ready to accept the toilet pan. Refer to their respective installation instructions for guidance if needed.
- Once assembly is completed, turn on the water supply, check for leaks and check the flush operation.

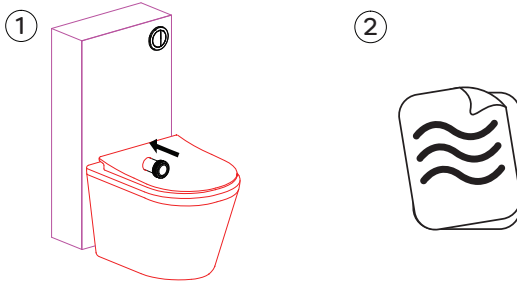

Troubleshooting

Please note: It is recommended to turn off the water supply before carrying out any internal maintenance.

Water continues to run into the toilet pan:

- Check the fill valve is closing when reaching the correct recommended water level. Ensure the float mechanism is not being obstructed and causing the cistern to continually fill thus causing an overflow into the toilet pan.

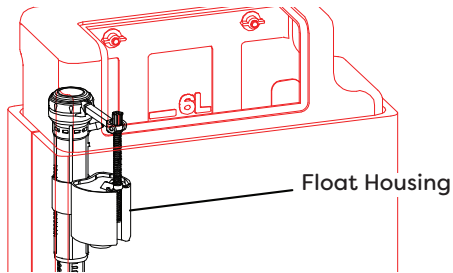

Insufficient or too much water entering the cistern tank:

- Adjust the fill valve by turning the float screw, until the desired level is reached. Turning the float screw anti-clockwise (A) will lower the water level, and turning the float screw clockwise (B) will increase the water level.

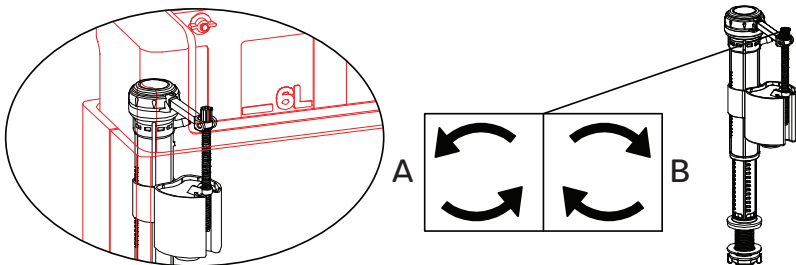

No flush operation when the push button is pressed:

- Remove the cabinet panel and press the two buttons on the flush plate. Check that the buttons engages the flush valve properly (that the vacuum tubes are properly connected). If the cistern flushes 'normal', ensure the flush plate is fitted in the correct orientation.

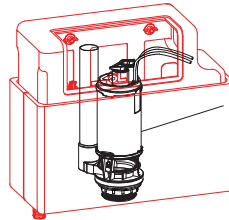
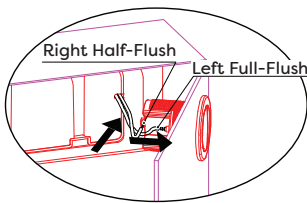

If the Flush valve does not flush when engaged, replace the flush valve.

Maintenance

Please note: Turn off the water supply and flush the toilet to drain away the water in the tank, it is also recommended to have a bucket under the tank to catch the draining water.

All of the maintenance measures resulting from troubleshooting above requires you to access the internals of the cistern tank and for the water supply to be turned off. Depending on the toilet design you may need to remove the toilet pan from its location to access the Inlet pipe, fill valve and flush valve.

To replace the Fill valve:

- Disconnect the inlet supply pipe from the fill valve, then remove the fill valve by unscrewing the nut on threaded tail. Remove the fill valve from the cistern tank. Once replaced, ensure all components are re-fitted.

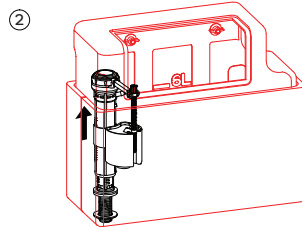
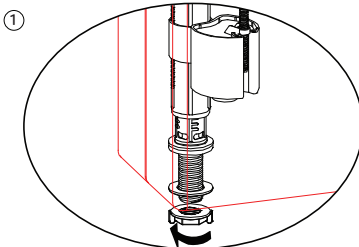

To replace the Flush Valve:

- Disconnect the vacuum pipes from the flush plate. Remove the flush valve from the cistern by unscrewing the flush connection pipe and base nut. Upon replacing, ensure the flush valve is in the correct orientation.

