

# Technical Details

## Schematic Diagram

**YW-MIRO02**

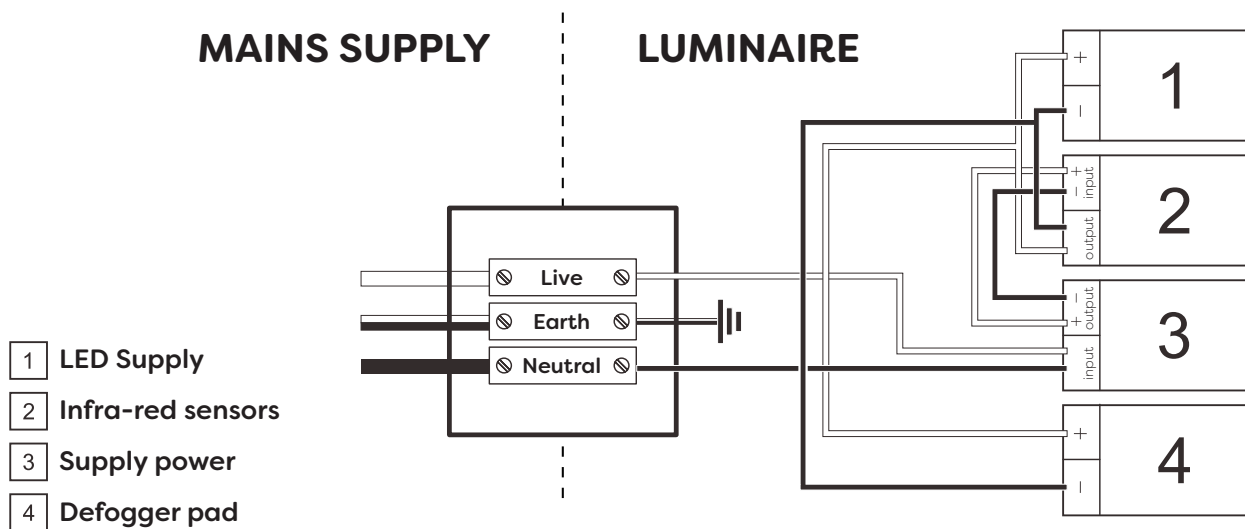

Mirror Weight (kg)	7.45kg
Mirror+Box Weight (kg)	9.65kg
Light Source	LED
Light source average span	50K HOURS
Total Rated Wattage (W)	33W
Lumens (Lm)	1024
Kelvins (K)	6000K

<b>FEATURES</b>
SENSOR SWITCH
DEMISTER
SHAVER SOCKET
MAGNIFYER

# Technical Details

## Data Reference

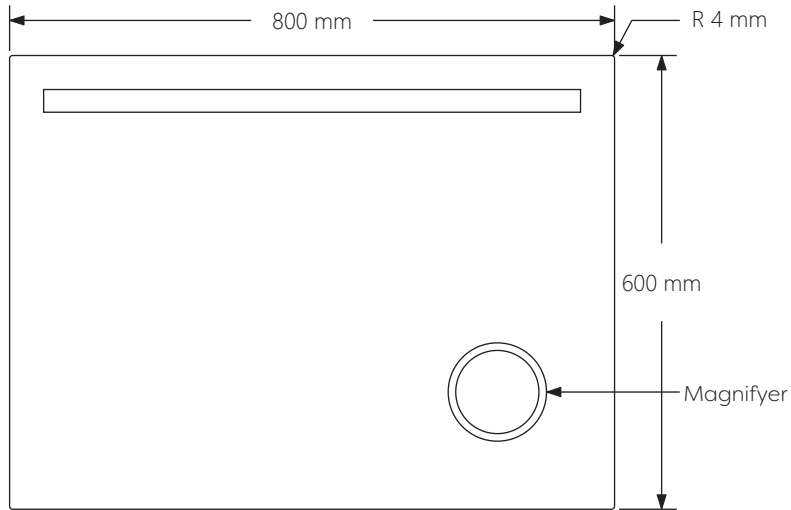

Front view

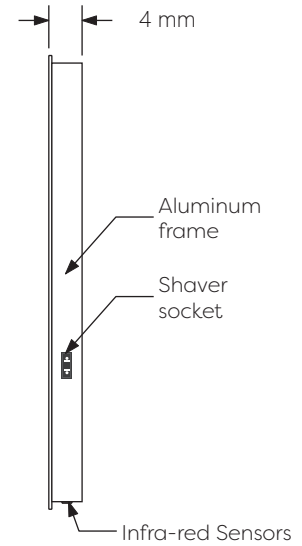

Side view

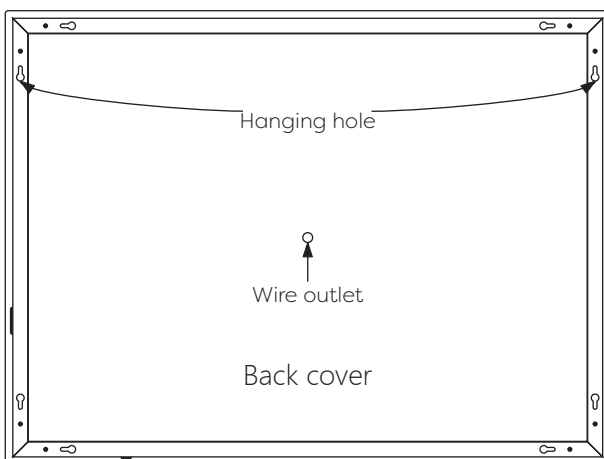

Back view

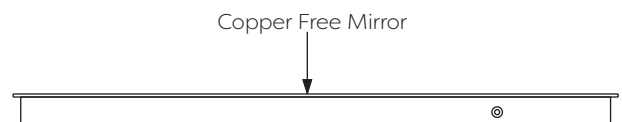

Bottom view