

TRITON

THAMES
**Dual control Thermostatic built-in
mixer shower with diverter**

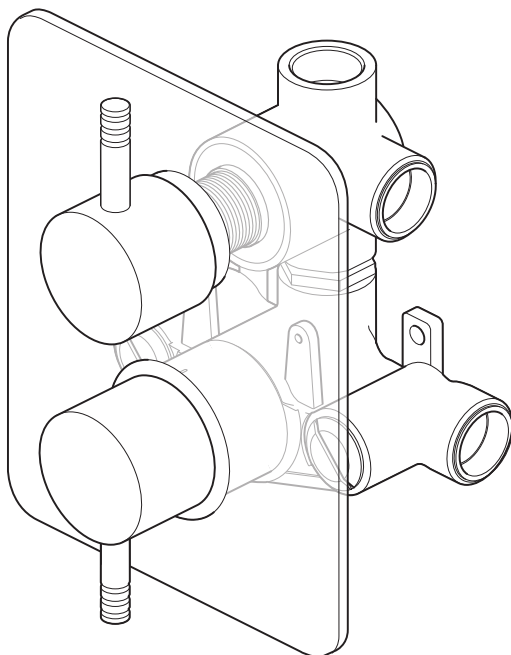

**Installation and
operating instructions**

INSTALLERS PLEASE NOTE THESE INSTRUCTIONS ARE TO BE LEFT WITH THE USER

CONTENTS	Page
MAIN COMPONENTS	1
INTRODUCTION.....	2
SITE REQUIREMENTS	2
SAFETY WARNINGS	2
PLUMBING REQUIREMENTS	3
WATER SYSTEM REQUIREMENTS	3
TYPICAL DOMESTIC INSTALLATIONS	4 - 5
INSTALLATION.....	6 - 11
BUILT-IN FITTING	7 - 8
Installation in a solid wall.....	7
Installation in a hollow wall	8
Installation in a panel wall or cubicle.....	8
FITTING THE MIXER	9
FITTING THE BULKHEAD PIPEWORK.....	9
LEAK TESTING	10
MAKING GOOD	10
BULKHEAD ASSEMBLY	10 - 11
To fit flow regulators.....	11
ANTI-SCALD PROTECTION	11
Recommended outlet temperatures.....	11
Fitting the coverplate.....	11
FITTING THE KNOBS	12
COMMISSIONING.....	12
ADJUSTING THE MAXIMUM TEMP SETTING	13
OPERATING THE SHOWER	13
APPROVALS	14
FLOW CHART	14
DIMENSIONS	15
SPARE PARTS.....	16
MAINTENANCE	17
FAULT FINDING.....	18 - 19
Guarantee, service policy, etc.	rear cover

To check the product suitability for commercial and multiple installations, please contact Triton's specification advisory service before installation.

Telephone: 0844 980 0730

Facsimile: 0844 980 0744

E mail: technical@tritonshowers.co.uk

MAIN COMPONENTS

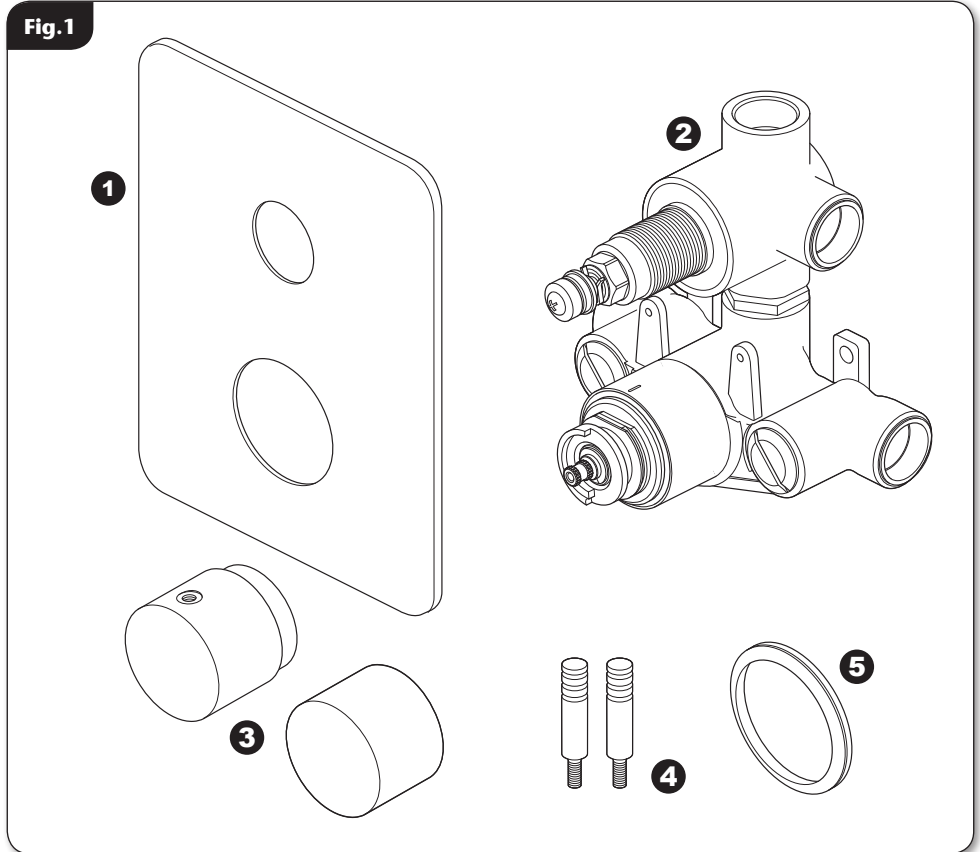

Ref. Description

1. Coverplate
2. Mixer shower body
3. Knobs X2
4. Levers X2
5. Coverplate seal X1

Note: water inlet and outlet fittings are **NOT** supplied with this product.

Water inlets require **x2 3/4" BSP fittings.**

Water outlet requires **x1 1/2" BSP fitting.**

All dimensions listed in this fitting book regarding the product and installation are approximate.

*All kits are for illustration purposes only and are not supplied unless otherwise stated.

INTRODUCTION

This book contains all the necessary fitting and operating instructions for your mixer shower. Please read them carefully and read through the whole of this book before beginning your installation.

The shower installation must be carried out by a suitably competent person and in sequence of this instruction book.

Care taken during the installation will give a long and trouble free life from your mixer shower.

SITE REQUIREMENTS

The installation must be in accordance with water supply (water fittings) regulation 1999 and/or local Bylaws.

Water pressure requirements

Running water pressure:

Low pressure*	- 0.5 bar min. 1.0 bar max.
High pressure	- 0.5 bar min. 5.0 bar max.

Maximum static water pressure:

Low & High pressure	- 10 bar
---------------------	----------

*This mixer shower is designed for high pressure systems found in the UK, but can be installed with low pressure gravity water systems with reduced flow rates.

For effective operation of the internal seals, the maximum static pressure must not be exceeded.

Pressure reducing valve

On sites where the running pressure is above 5 bar, the use of a suitably sized pressure reducing valve fitted in the cold mains supply pipe work can provide nominally equal pressures at the mixer shower.

Water minimum flow rate

For best performance within the specified running pressure range a minimum flow of 8 litres per minute should be available to both inlets.

Water temperature requirements

Recommended maximum:	= 65°C
Minimum hot water temperature:	= 55°C
Maximum cold water temperature:	= 25°C

A stored water temperature of 60°C is considered sufficient to meet all normal requirements and will minimise the effects of scale in hard water areas.

Water temperature adjustment and thermal safety

The mixed water temperature can be adjusted from cold through to a top limit which must be preset during installation with full anti-scald protection throughout the range (35°C to 40°C) providing the hot water temperature at the inlet remains 10°C above the outlet temperature.

Should there be a loss of flow to either incoming supply then- water from the shower will stop or be reduced until both supplies are restored.

SAFETY WARNINGS

- DO NOT** choose a position where the shower could become frozen.
- DO NOT** connect this mixer shower to any form of tap or fitting not recommended by the manufacturer.
- DO NOT** allow the inlet pressure or flow rates to operate outside the guidelines laid out in 'site requirements'.
- DO NOT** connect the mixer shower to a gravity hot supply and a mains cold supply (or vice versa).

Replacement parts can be ordered from Customer Service. See 'spare parts' for details and part numbers.

PLUMBING REQUIREMENTS

DO NOT use jointing compounds on any pipe fittings for the installation.

DO NOT solder fittings near the mixer unit as heat can transfer along the pipework and damage the mixer valve.

DO NOT subject the unit to a water temperature above 80°C during installation, use, maintenance or disinfection.

IMPORTANT:

- The layout and sizing of pipework **MUST** be such that nominally equal inlet supply pressures are achieved and the effects of other draw-offs are minimised.
- The pipe-work should be installed such that other taps and appliances being operated elsewhere on the premises do not significantly affect the flow.
- When connecting pipe-work avoid using tight 90° elbows; swept or formed bends will give the best performance.
- The hot water pipe entry **MUST** be made to the left-hand side inlet, marked HOT, 'H' or with a red/orange label.
- Suitable isolating valves (complying with Water Regulations and Bylaws) **MUST** be fitted on the hot and cold water supplies to the shower as an independent means of isolating the water supplies should maintenance or servicing be necessary.
- It is preferable to flush the pipe-work to clear the system of debris and check for leaks before connecting to the mixer.
- The mixer inlets contain removable filters that may become blocked if debris is not flushed through before fitting.

(Commercial applications)

- Triton recommends for all commercial applications that, easily accessible, in-line filters are used to aid maintenance.

Hard water areas

- a. If it is intended to operate the shower in areas of hard water (above 200-ppm temporary hardness), a scale inhibitor may have to be fitted. For advice on the scale inhibitor, please contact Customer Service.
- b. For best performance the showerhead **MUST** be regularly cleaned to remove scale and debris.

WATER SYSTEM REQUIREMENTS

This mixer shower is suitable for:

- Gravity water systems.
- Pumped gravity systems.
- Fully modulating type combination boilers.
- Multi-point hot water heaters.
- Thermal storage.
- Unvented systems.

When installing this mixer with a Combination or multi-point boiler, it may be necessary to install flow regulation.

Check that the appliance is capable of delivering hot water at a minimum switch-on flow rate of 3 litres per minute. At flow rates between 3 and 8 litres per minute, the appliance **MUST** be capable of raising the water temperature to 52°C (minimum).

Water temperature at the inlet of the mixer valve **MUST** remain relatively constant when flow rate adjustments are made (refer to the appliance-operating manual to confirm compatibility with this mixer shower).

Where thermal store systems and instantaneous gas water heaters are used, if excessive draw-off take place the appliance may not be able to maintain an adequate output temperature. This could result in the shower temperature becoming noticeably cooler.

Flow regulators can be fitted with high-pressure water systems to reduce flow rate and assist economy.

The hot supply temperature **MUST** remain a minimum of 10°C hotter than the required blend temperature for optimum performance.

Fig.2

(diagrammatic view – not to scale)

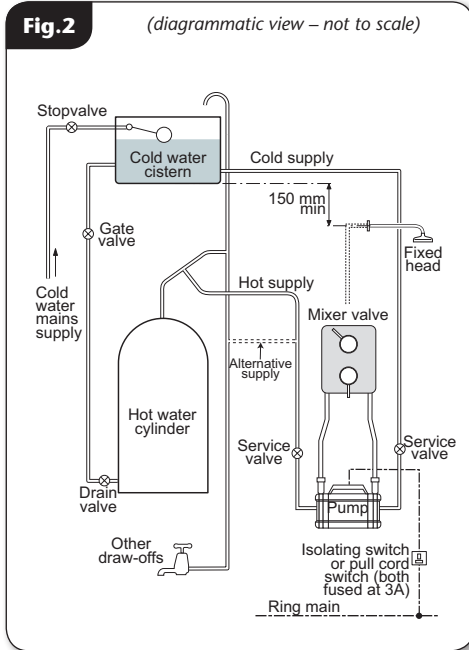

TYPICAL DOMESTIC INSTALLATIONS

Pump assisted gravity fed systems (fig.2)

The pump **MUST** be fed from a cold water cistern and hot water cylinder providing nominally equal pressures.

The shower control can be used with a gravity fed system in conjunction with a pump to boost pressures.

Refer to the pump installation guide to establish the minimum head requirements for automatic operation of the pump.

Instantaneous gas-heated systems, e.g. combination boilers (fig.3)

The shower control **MUST** be installed with a multi-point gas water heater or combination boiler of a fully modulating design (i.e. to maintain relatively stable hot water temperatures).

A drop tight pressure reducing valve **MUST** be fitted if the supply pressures exceed 5 bar running.

An expansion vessel may be fitted, and regularly maintained, to prevent the shower mixer being damaged by excess pressures. This may already be installed within the boiler (check with manufacturer) and is in addition to the normally larger central heating expansion vessel.

NOTE: In order to ensure the best performance from the shower when connected to an instantaneous water heater, the appliance must be capable of raising the temperature of the incoming water to a minimum of 52°C (125°F) and delivering a flow rate of not less than eight litres per minute. Please see pages x & x for information on installing flow regulators.

Fig.3

(diagrammatic view – not to scale)

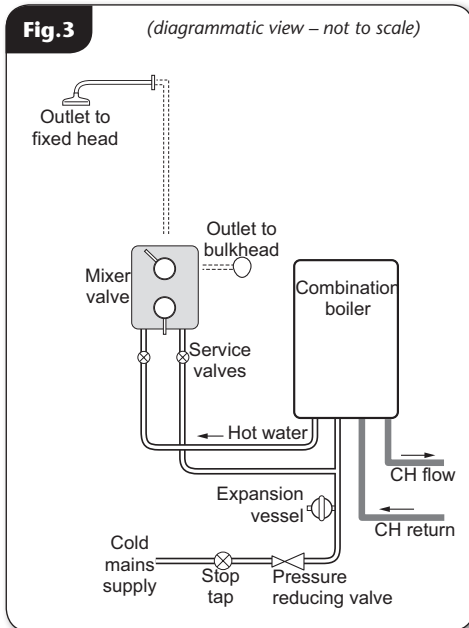

Unvented mains pressure systems (fig.4)

The shower control can be installed with an unvented, stored hot water cylinder.

For systems with no cold water take off after the appliance reducing valve, it will be necessary to fit an additional drop tight pressure-reducing valve when the mains pressure is over 5 bar. The drop tight pressure reducing valve must be set at the same value as the unvented package pressure reducing valve.

NOTE: An additional expansion vessel may be required if a second pressure-reducing valve is installed. This does not apply to packages with a cold take off after the pressure-reducing valve to the cylinder.

Mains pressurised thermal store systems (fig.5)

Packages of this type, fitted with a tempering valve (blender valve) can be used. A drop tight pressure reducing valve **MUST** be fitted if the supply pressures exceed 5 bar running.

An expansion vessel **MUST** be fitted, and regularly maintained, to ensure, the unit, is not damaged by excess pressures. This may already be installed externally or internally within the thermal store (check with thermal store manufacturer).

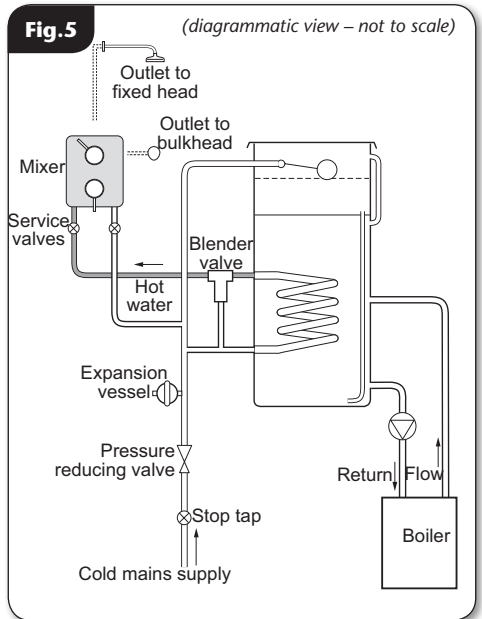
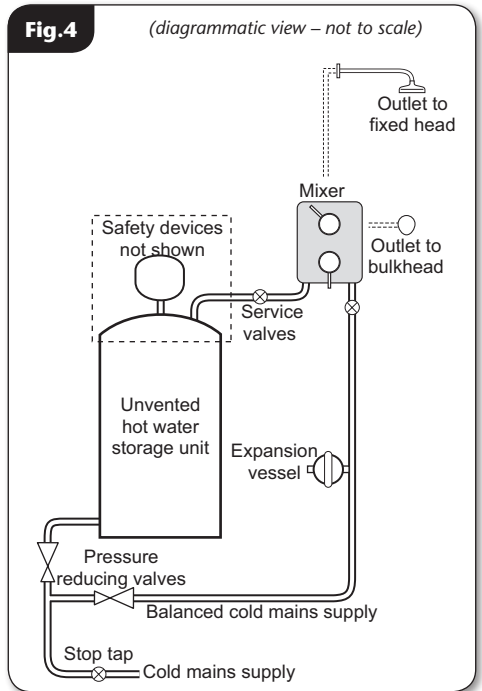
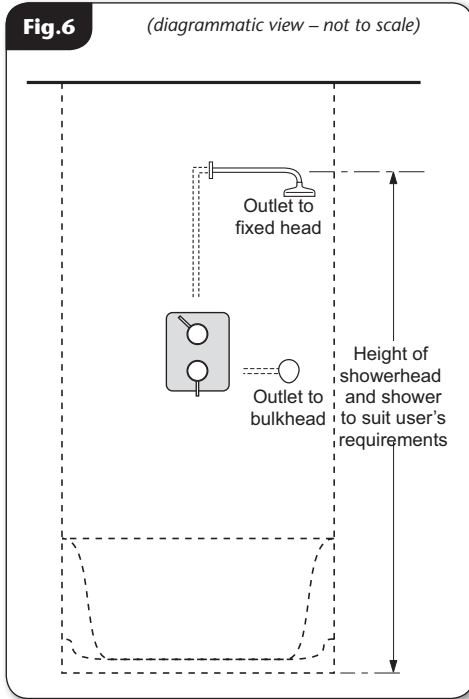

Fig.6

(diagrammatic view – not to scale)



INSTALLATION

Preparing the mixer valve

Check the contents to make sure all parts are present.

Before starting the mixer installation, make sure all the openings on the valve are carefully covered to stop ingress of any debris, etc. while routing the supply pipework.

The shower valve is suitable for built-in installation in:

- a solid wall,
- a stud partition wall
- dry lined wall
- or fixing to a shower cubicle or panel.

Siting of the shower and accessories

Refer to (fig.6) for correct siting of the shower.

The mixer valve should be positioned, as detailed, with all controls within comfortable reached of the user.

The diverter outlet from the mixer is on the right hand side.

The unit must be positioned vertically with the outlet port at the top (marked with an 'arrow' on the brass body).

Fig.7

Typical building-in dimensions

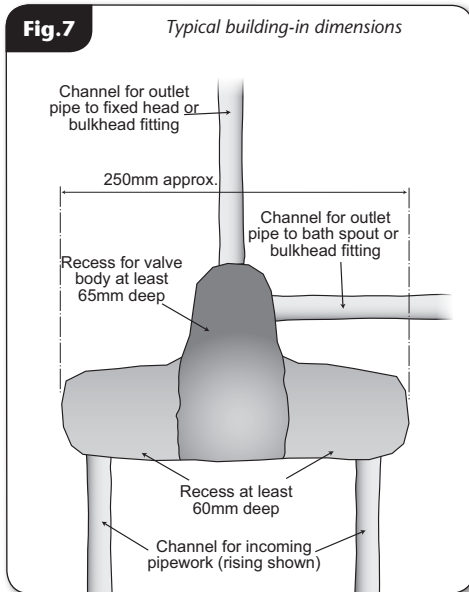

Supply pipe work

Complete the pipework to the shower area having decided on the position of the shower and direction of pipe entry (for example rising, falling or rear entry)

The hot and cold water pipes should not be permanently attached to the wall within one metre of the valve, before installation is complete, to allow for final adjustment of the valve position.

Rear entry supplies

Using a spirit level, mark the route of incoming hot and cold water supply pipes.

NOTE: The distance between centres will be determined by the fittings used (not supplied) (fig.7).

BUILT-IN FITTING

The following are typical thicknesses and are given as a guide only:

Tile	6 – 10mm
Adhesive	2 – 3mm
Plasterboard	9.5 – 12.5mm
Plaster finish	2 – 3mm

Maximum tile thickness to be 10mm.

When installing into a stud partition or other hollow wall structure, the installer may wish to consider building rear supports or other options for fitting the mounting plate. Such options are beyond the scope of this guide.

Use the cover plate as a template (**making sure that the hole is smaller than the outer dimensions of the cover plate**) when cutting the opening for installing the shower into a solid wall, stud partition or hollow wall structure.

The building-in depth for the mounting plate is given in (fig.8) from the plaster finish but this is dependent upon tile and adhesive thicknesses.

The inlet elbows allow for either rising, falling or rear entry hot and cold water supplies.

NOTE: *To ease future requirements for cleaning and maintenance of the unit, it is advisable to route both the incoming and outgoing pipework from the same direction. Access to the integral strainers will also be improved with this layout.*

Installation in a solid wall

- Decide on the shower position and determine whether the hot and cold water supplies will enter the shower from top (falling) or bottom (rising) or rear.
- As a guide for the size of hole, it should be large enough to accept the valve complete with the inlet and outlet fittings and also allow access for connection to the pipework.
- Remove the plaster and brickwork to the required depth and chase out any additional areas of the wall to give access to the pipework to and from the valve plus any outlet fittings. Note that the valve body requires a deeper recess than the inlet and outlet fittings.

Fig.8

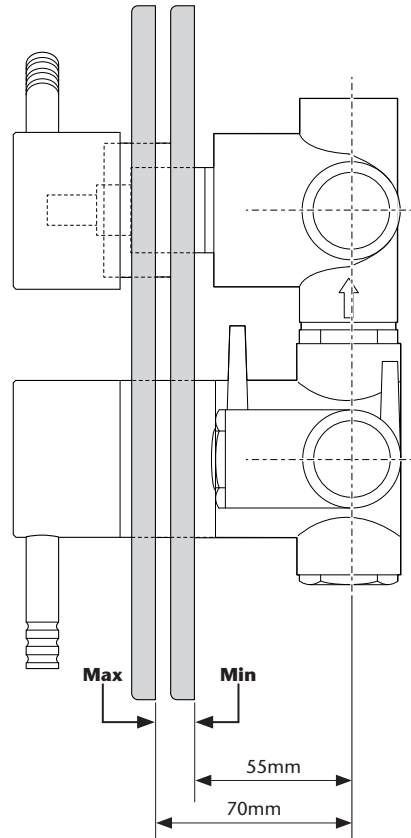

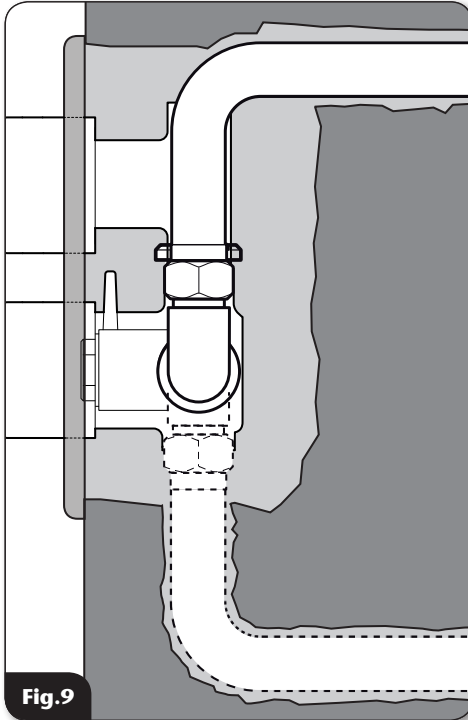

Fig. 9

NOTE: The outlet pipework must end in a suitable female thread parallel 15mm x 1/2" BSP fitting (not supplied).

- Offer the valve body up to the wall and mark the fixing holes. Remove the valve, drill and plug the wall. Route the pipework to valve body position.

Installation in a hollow wall

- Decide on the shower position and determine whether the hot and cold water supplies will enter the shower from the top (falling) or bottom (rising) or rear (**fig. 9**).
- When installing into a stud partition or other hollow wall structures, the installer will need to consider fabricating rear supports or other options. Such options are beyond the scope of this guide.
- Mark the route of the incoming and outgoing pipework.
- Take out the plasterboard (use the cover plate as a template). Offer the valve body up to the fabrication and mark the fixing holes.
- Remove the valve and drill the holes. Route the pipework to the valve position.

Installation in a panel wall or cubicle

When installing into a panel or cubicle structure the installer will need to consider fabricating rear supports or other options. Such options are beyond the scope of this guide.

Typically, there should be at least 65mm space from the surface of the panel to the rear of the valve body.

IMPORTANT: Access to the rear of the valve must be available.

- The controls require two holes to be cut out of the panel or cubicle. Use the face plate as a template to mark the hole positions then extend further to allow access for the filters.
- Route the pipework to valve position.

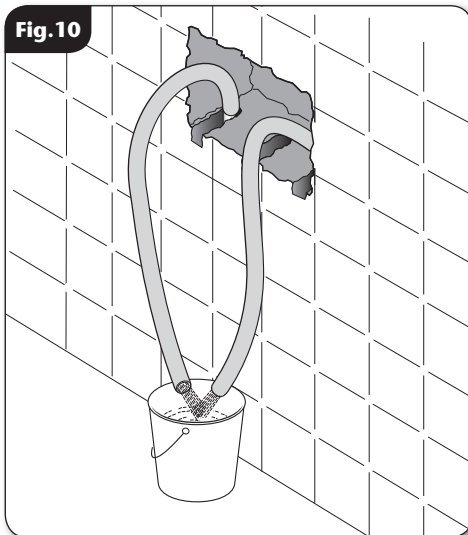

Fig. 10

FITTING THE MIXER

- Mark the position of two locating screws.
- Drill and plug the holes. (*Use an appropriate masonry drill, but if the wall is plasterboard or a soft building block, use special wall plugs and a suitable drill bit.*)

IMPORTANT: Make sure that all supply pipework has been flushed through before fitting the mixer (**fig.10**).

- Connect the hot water supply to the inlet marked HOT, 'H' or red/orange label and connect the cold water supply to the inlet marked COLD, 'C' or blue label.
- Tighten all compression fittings
- Secure the mixer to the wall.

Outlet pipework - both outlets

PLEASE NOTE: X1 outlet bulkhead and X1 straight connector are supplied with the mixer. If the top outlet to a fixed showerhead is required, the appropriate items will need to be purchased separately (the information below outlines both fixed head and diverter bulkhead fitting).

- Complete both the fixed head and bulkhead outlet pipework (**fig.11**) in a ½" BSP x 15mm female thread elbow or appropriate fitting.

NOTE: The elbow fitting is not supplied as variations in installations require the selection of the most suitable fitting. Please consult the fitting instructions supplied with any fixed head product before undertaking the installation.

Bulkhead outlet fitting

- Screw the male-thread connector into the selectrf female fitting using PTFE tape to give a watertight joint.

IMPORTANT: If fitting a bath spout **DO NOT** fit the straight connector to the diverter outlet.

NOTE: The supplied X1 male-thread connector has a shoulder. If fitting into a flush wall, make an additional 8mm allowance for this shoulder at the finished surface. The connectors can be cut to size if required.

- The threaded connectors should protrude from the wall surface between 8mm & 13mm (**fig.11**)

Fig.11

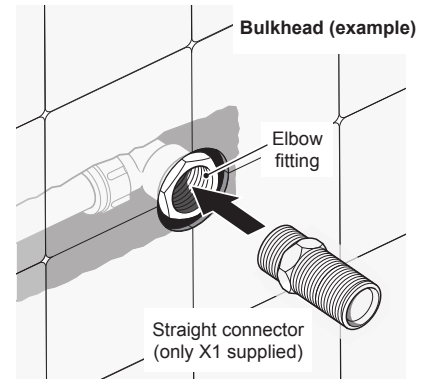
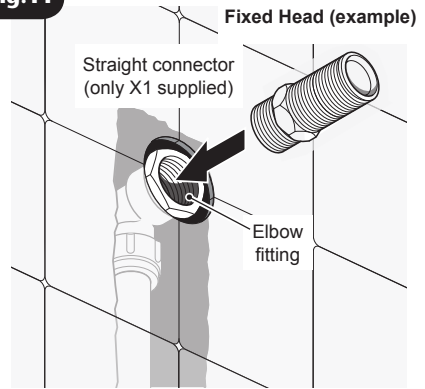

Fig.11

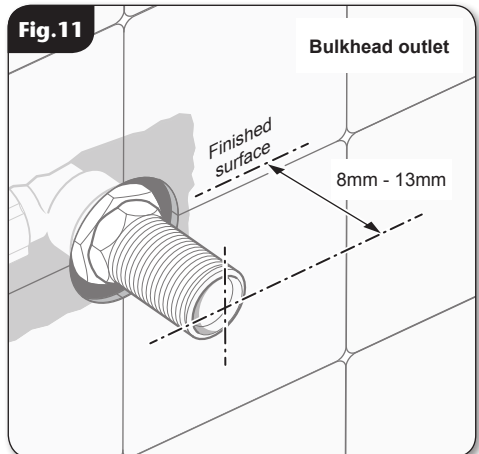
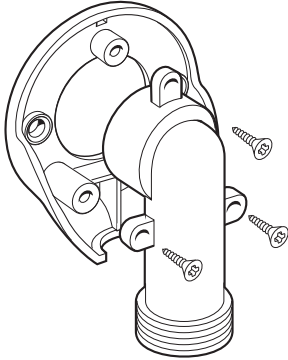

Fig. 12



LEAK TESTING

Direct the outlet of the mixer to waste. Open the isolating valves to the shower and check for leaks. Remedy any leaks found.

MAKING GOOD

Make good the wall and complete the tiling.

- If the tiles are accurately cut, then the coverplate will seal around the hole in the tiles, and the valve unit will be able to be removed from the wall without the need to break any tiles.

Make sure the grout lines around the valve are flush with the tiles in order to provide a smooth sealing surface for the coverplate.

Fig. 13

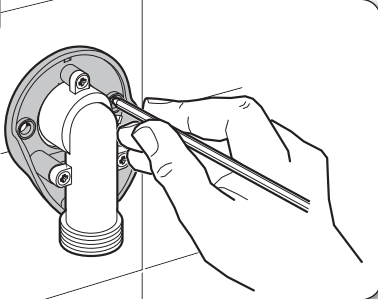

BULKHEAD ASSEMBLY

- Screw the bulkhead elbow to the bulkhead body with the three screws supplied (**fig. 12**).
- Screw the completed assembly onto the threaded connector temporarily to mark the position of the two fixing holes for securing the bulkhead to the wall (**fig. 13**).

NOTE: *If screw thread protrudes too far out of the wall, it can be cut to the correct length using a hacksaw. Care should be taken to make sure that any sharp edges or swarf are removed before fitting the bulkhead.*

- Unscrew and remove the bulkhead assembly. Check the location of the pipe in the wall before drilling.
- Drill and plug the wall. *(An appropriate drill bit should be used. If the wall is brick, plasterboard or a soft building block, appropriate wall plugs and screws should be fitted).*
- If fitting to a hollow wall structure, it may be preferable to secure the bulkhead by applying a bead of silicon seal to the back of the bulkhead.
- Apply PTFE tape to the threaded connector.
- Screw the bulkhead assembly onto the threaded connector until tight to the wall and the two fixing holes are aligned. Secure to the wall with the two screws supplied (**fig. 14**).

Fig. 14

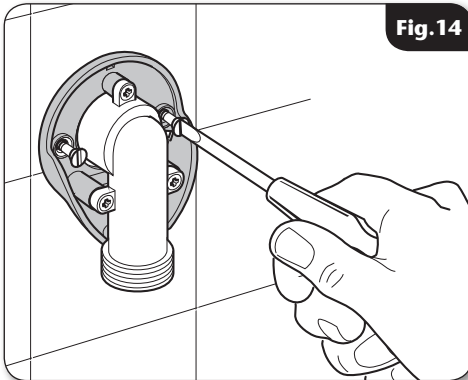

- Finish by clipping the cover onto the bulkhead, making sure the protruding legs locate in the bulkhead body.

To fit a flow regulator - bulkhead outlet

To fit the flow regulators (flexible hose connection) press it into the outlet of the bulkhead, correctly. Please note the flow regulator is only designed to work in one direction (**fig.15**).

ANTI-SCALD PROTECTION

It is important that the mixer valve is tested regularly to prevent the risk of scalding and guarantee user safety. This can be carried out as follows: with the mixer blend temperature set at 38°C isolate the cold water supply. The outlet flow rate will reduce to a safe level.

Recommended outlet temperatures

The **BuildCert TMV** scheme recommends the following set maximum mixed water outlet temperatures for use in all premises:

44°C - for bath fill but see notes below.

41°C - for showers.

41°C - for washbasins.

38°C - for bidets.

The mixed water temperatures must never exceed **46°C** at terminal fitting.

The British Burns Association recommends **37** to **37.5°C** as a comfortable bathing temperature for children. In premises covered by the Care Standards Act 2000, the maximum mixed water outlet temperature is **43°C**.

FITTING THE COVERPLATE

Fit the coverplate over the valve body and slide tight to the wall.

Make sure the seal in the openings stays in place as it slides over the valve body. A smear of liquid soap on the seal will ease this procedure (**fig.16**).

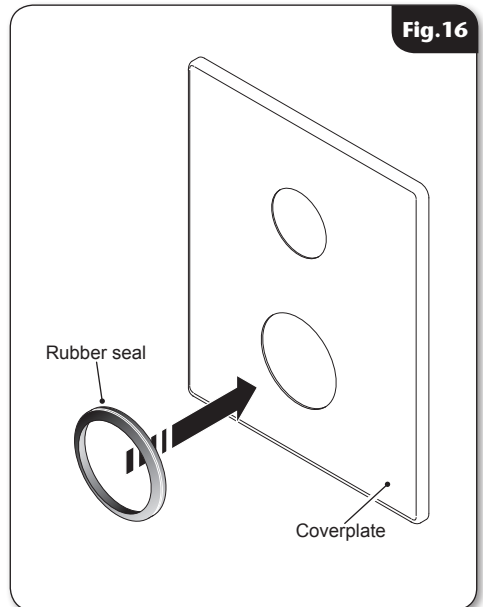
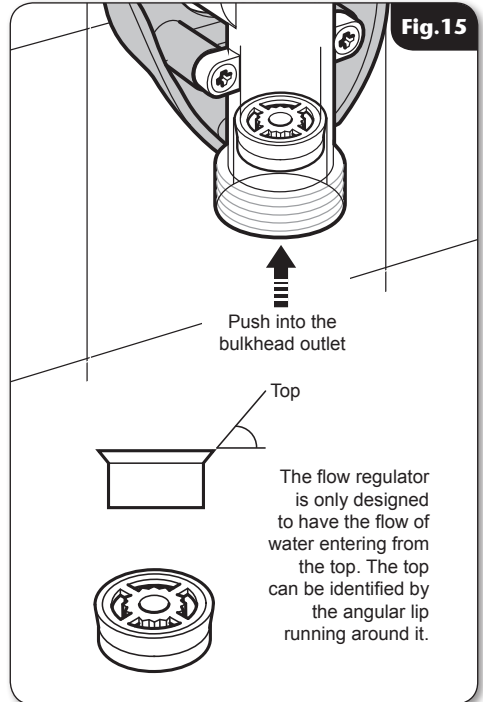

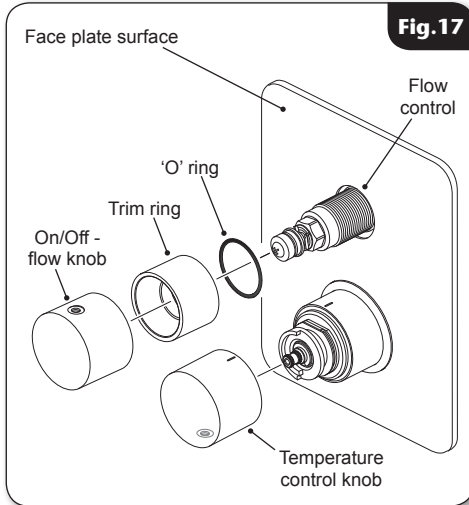

FITTING THE KNOBS (fig.17)

- Fit the trim ring making sure that the 'O' ring is seated in the trim rings recess. This will give a seal against the top of the backplate.
- Temporarily fit the flow and temperature knobs for commissioning. Secure the knobs by using an allen key to tighten the small grub screw located in the handle hole. Align the marks on the temperature knob which should place the lever hole at 6 o'clock. The lever hole of the flow knob should be at 12.

COMMISSIONING

- Make sure that both the hot and cold water supplies are fully open and at (or near to) their desired temperature and pressures, and are within the requirements as stated on **page 2**.
- Make sure the temperature control knob is at the maximum temperature setting (rotated fully clockwise).
- Make sure the bulkhead outlet is directed to waste.
- Start the water flow by turning the flow knob anti-clockwise towards the handset position marked on the coverplate (**fig.18**).
- Allow the shower to run at the maximum temperature setting until the water temperature has stabilised. Rotate the temperature control until your desired maximum showering temperature is reached.

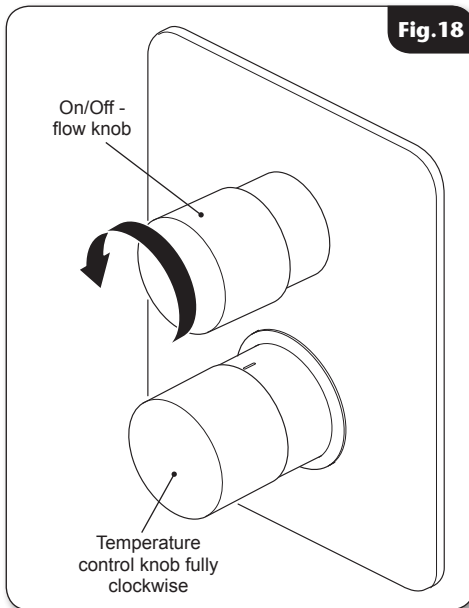

The mixer has a temperature stop to prevent accidental rotation to higher temperatures. This is adjustable to provide a maximum temperature of 35°C – 40°C and should be checked on site to guarantee user safety.

Temperature adjustment range

The mixed water temperature can be adjusted from cold through to a top limit (which can be pre-set during installation – factory set at approximately 38°C) with full anti-scald protection throughout the range.

ADJUSTING THE MAXIMUM TEMPERATURE SETTING

- Remove the temperature control knob.
- Turn the flow control fully anti-clockwise. With a steady flow running, adjust the temperature spindle until the temperature is about 38°C - use a thermometer to establish the temperature (turn clockwise for hotter or anti-clockwise for cooler).
- When the showering temperature is satisfactory turn off the shower.
- Refit the temperature control knob, making sure the maximum temperature stop pin is as close to the flat edge of the maximum temperature stop face as possible (**fig.19**). Secure with the fitting screw once the commissioning procedure is complete and fit the lever.

OPERATING THE SHOWER (fig.20).

- To start the shower, rotate the flow control lever fully to the left for maximum flow.
- To stop the water flow, rotate the flow control lever fully to the right.
- To adjust the water temperature, rotate the temperature control — clockwise for a cooler shower or anti-clockwise for a hotter shower.

CAUTION: Exposed metal and chromed surfaces may become hot during use.

Fig.19

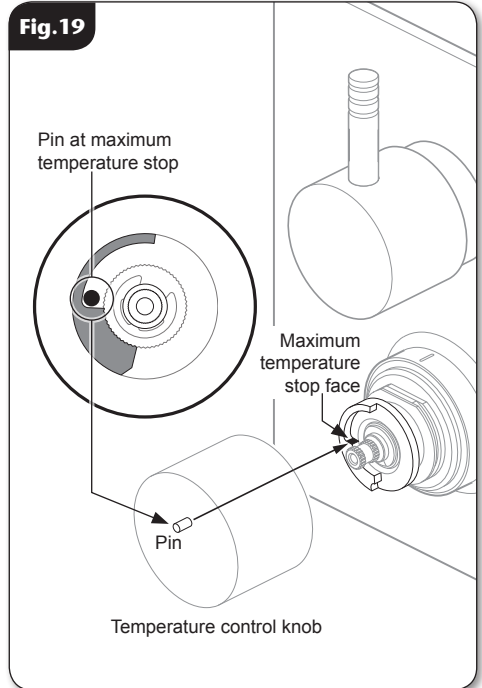
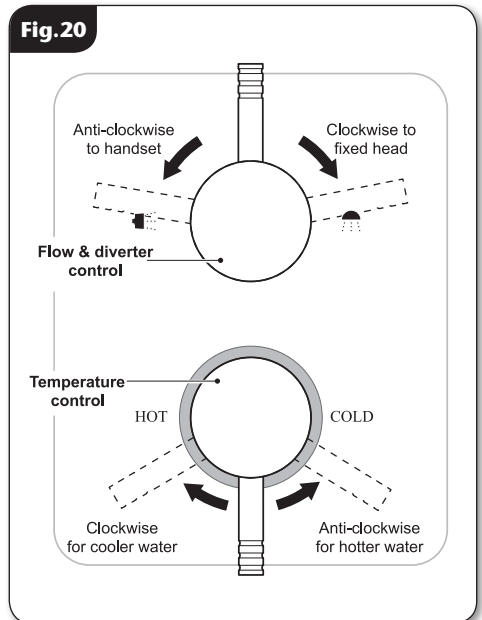

Fig.20



APPROVALS

This mixer valve has been designed to comply with the requirements of: **BS EN 1111**
BS EN 1287
WRAS

FLOW CHART

Flow Rate (l/m)	4.9	6.5	8.0	9.5	10.5	15.5	21.5	26.5	31.0	35.0
Pressure (bar)	0.1	0.2	0.3	0.4	0.5	1.0	2.0	3.0	4.0	5.0

Conditions for test

Inlet temperatures comply with EN1111 requirements
Outlet temperature 38°C
Flow Control Fully Open
Open Outlet - No hose or showerhead connected

Flow Rate (l/m)

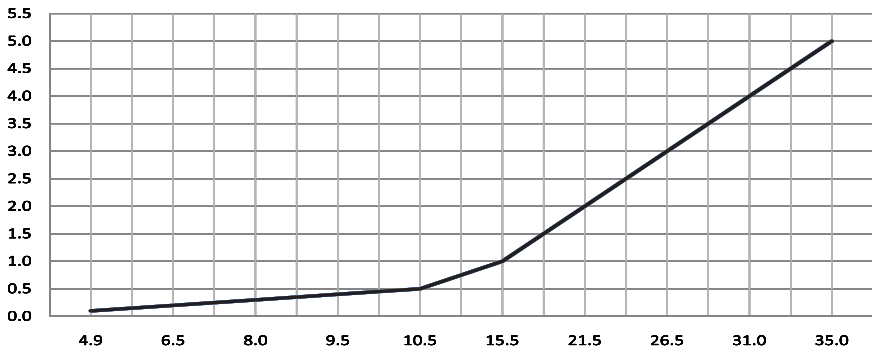

DIMENSIONS

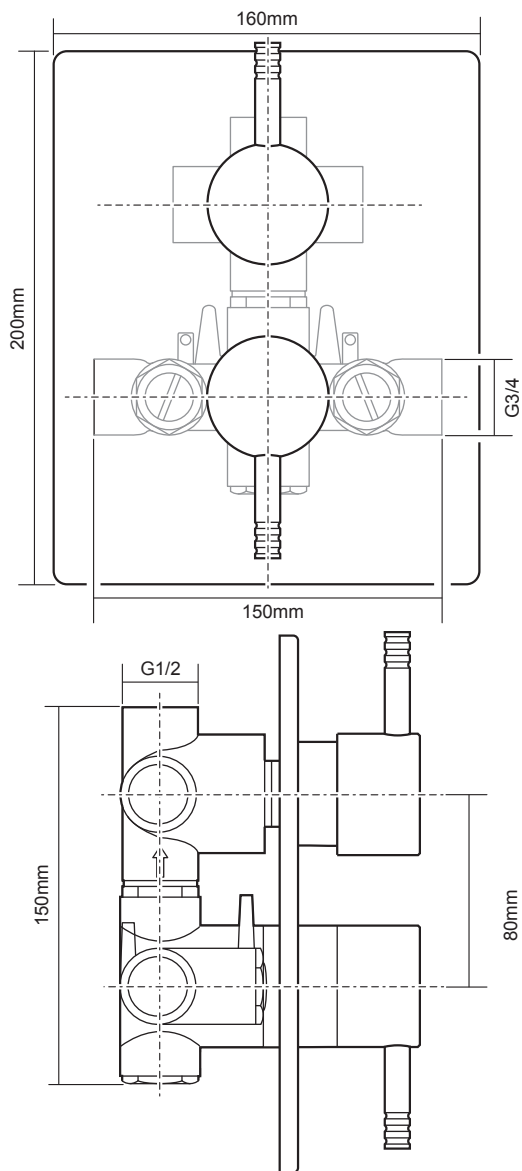

All dimensions listed in this fitting book regarding the product and installation are approximate.

SPARE PARTS

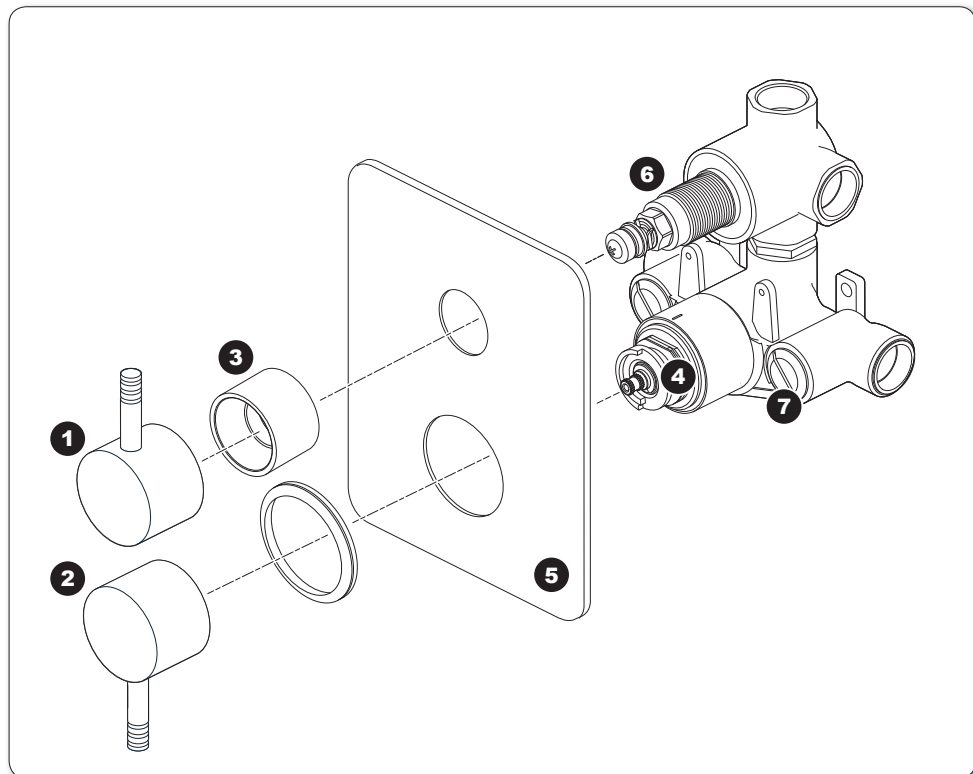

Ref.	Description	Part No.
1	Flow & diverter control	83308900
2	Temperature control	83308890
3	Threaded trim ring.....	83307230
4	Thermostatic cartridge	83307250
5	Face plate and seal.....	86001370
6	Adaptor.....	83308920
7	Filter	83307240
-	Flow & diverter valve	83308910
-	Flow regulator.....	22011290

MAINTENANCE

The following maintenance procedure must be carried out for commercial and health care premises, but is not necessarily required for domestic installations.

Maintenance of the unit is required to give continued performance after installation and that it continues to provide scald prevention.

NOTE: *A thermostatic mixing valve in need of maintenance can be undetectable in normal use and only becomes apparent when a disruption occurs in the hot or cold water supply temperatures or pressures.*

The frequency of routine maintenance of the internal of the valve will depend mainly on the water supply condition. Experience of local conditions will dictate the intervals for inspection and in-service testing; guidance has been given below which can be adjusted for local requirements.

- a) Initially check the filters for debris once every three months and clean if necessary.
- b) Perform a thermal shut off test every three months, and check the maximum temperature setting. See the 'Commissioning' section for the details of this test and readjustment of the maximum temperature setting if required.
- c) If the maximum water temperature varies by more than 2°C from the commissioned setting then carry out the following checks
 - Check the isolating valves are fully open.
 - Check the internal surface for scaling.

If the body requires descaling then it should be removed from the pipework to carry this work out (all rubber parts must be removed before descaling).

- Check the function of the non-return valves

The non-return valves (NRVs) prevent cross-flow between hot and cold supplies under unequal pressure conditions. They are designed for long life with no maintenance.

If these checks do not highlight the reason for the temperature variation, then internal components will require replacement; please see the spare parts list.

Cleaning

Triton recommends that all products are cleaned using warm, soapy water.

Do not use abrasive or aggressive chemical cleaning products as this may affect the product surface finish and invalidate your guarantee.

Cleaning the filters (fig.A)

It is advised that this should be carried out by a qualified person.

- Turn off the water supplies before starting.
- To gain access to the filters remove the filter housings from the front of the unit.
- Dissassemble as shown below.
- Wash the filter thoroughly under running water, use a suitable brush to remove all debris.
- Reassemble the shower.

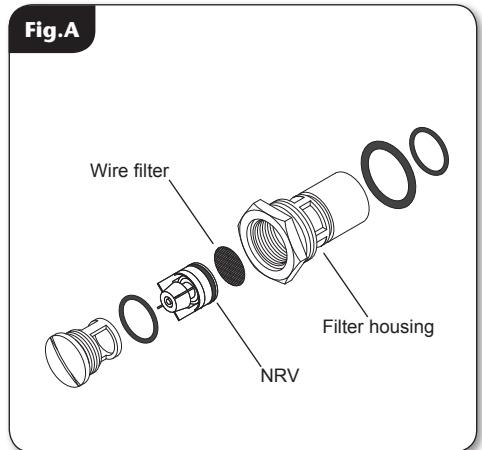

Disinfection

Where chlorine is used for the disinfection of water systems all relevant guidelines and approved codes of practice must be strictly followed. Failure to comply with the relevant guidelines and approved codes of practice may invalidate your guarantee.

WARNING!
DO NOT use 'powerful' abrasive or solvent cleaning fluids when cleaning the shower as they may damage the fittings.

FAULT FINDING

The following can be carried out by a competent person

Problem/Symptom	Cause	Action/Cure
1 Water too hot.	1.1 Temperature control incorrectly commissioned.	1.1.1 Refer to commissioning section.
	1.2 Not enough cold water flowing through shower.	1.2.1 Reposition the temperature control.
	1.3 Increase in the ambient cold water temperature.	1.3.1 Reposition the temperature control.
	1.4 Cold water supply blocked.	1.4.1 Turn off shower and consult a competent plumber or contact Customer Service.
	1.5 High volume of cold water drawn off elsewhere.	1.5.1 Reduce the simultaneous demand from the mains supply.
2 Water too cold.	2.1 Temperature control incorrectly commissioned.	2.1.1 Refer to commissioning section.
	2.2 Not enough hot water flowing through shower.	2.2.1 Reposition the temperature control.
	2.3 Decrease in the ambient cold water temperature.	2.3.1 Reposition the temperature control.
	2.4 Insufficient hot water supplies from the heating system.	2.4.1 Make sure heating appliance is set to maximum or has sufficient stored hot water.
		2.4.2 Make sure heating appliance is igniting by trying a hot water tap elsewhere.
2.5 Hot water supply blocked or restricted.	2.5.1 Turn off shower and consult a competent plumber or contact Customer Service.	
3 High water flow and/or poor performance on a mains fed system.	3.1 Flow regulators not fitted.	3.1.1 Fit the supplied flow regulators in the inlet elbows (see 'To fit a flow regulator' on page 12).

FAULT FINDING

Problem/Symptom	Cause	Action/Cure
4 Water does not flow or shower pattern collapses when another outlet is turned on.	4.1 Water supplies cut off.	4.1.1 Check water elsewhere in house and if necessary contact local water company.
	4.2 Shower unit blocked.	4.2.1 Inspect the filters. Clean if necessary.
	4.3 Blockage in pipework.	4.3.1 Turn off the shower and consult a suitably competent plumber.
	4.4 Showerhead blocked.	4.4.1 Clean the showerhead.
	4.5 System not capable of supplying multiple outlets at the same time.	4.5.2 Make sure stop or service valve is fully open.
4.5.3 Check if there is sufficient water pressure.		

The following is recommended for a professional qualified installer only

5 Water too cold.	5.1 Running pressure is excess of maximum recommended.	5.1.1 Fit a pressure reducing valve.
6 Shower controls noisy when in use.	6.1 Running pressure in excess of maximum recommended.	6.1.1 Fit a pressure reducing valve.
7 Shower will not shut off.	7.1. Pipework not flushed out before connecting to the unit. Internal components damaged.	7.1.1 Service valve.

UK SERVICE POLICY

In the event of a product fault or complaint occurring, the following procedure should be followed:

1. Telephone Customer Service on **0844 980 0750** having available, your details including post code, the model number and power rating of the product, together with the date of purchase and, where applicable, details of the particular fault.
2. If required, the Customer Service Advisor will arrange for a qualified engineer to call.
3. All products attended to by a Triton service engineer must be installed in full accordance with the Triton installation guide applicable to the product. *(Every product pack contains an installation guide, however, they can also be bought via our Customer Service Spares Department).*
4. Our engineer will require local parking and if a permit is required this must be available to the engineer on arrival at the call.
5. It is essential that you or an appointed representative (*who must be over 18 years of age*) is present for the duration of the service engineer's visit. If the product is in guarantee you must produce proof of purchase.
6. Where a call under the terms of guarantee has been booked and the failure is not product related (*i.e. scaling and furring, incorrect water pressure, pressure relief device operation or electrical/plumbing installation fault*) a charge will be made. A charge will also be issued if nobody is at home when the service engineer calls or adequate parking/permit is not available.
7. If the product is no longer covered by the guarantee an up front fixed fee will be charged before the site visit.
8. Should proof of purchase not be available on an "in-guarantee" call, or should the service engineer find that the product is no longer under guarantee, the engineer will charge the same fixed price and the customer will be expected to pay the engineer before he leaves. If payment is not made on the day an administration charge will be added to the fixed charge.
9. If a debt is outstanding from a previous visit, or from any other Triton purchase. Triton reserves the right to withhold service until the debt has been settled.
10. Triton takes the health, safety and wellbeing of its employees very seriously and expects customers to treat all staff members with respect. Should any employee feel threatened or receive abuse, either verbally or physically, Triton reserves the right to withhold service and will support the employee with a legal prosecution.

Replacement Parts Policy

Availability: It is the policy of the manufacturer to maintain parts availability for the duration of production and a period of five years thereafter, in accordance with industry standards.

Spare parts are available via our website, www.tritonshowers.co.uk, or by telephoning Triton Customer Service Spares Department. Payment should be made by credit/debit card (excluding American Express or Diners Card). Payment can also be made by pre-payment of a pro forma invoice by cheque or money order.

Telephone orders are based on information given during of the call.

Before contacting Triton, please verify your requirements using the information contained in the supplied user guide. Triton cannot accept liability for incorrect part identification.

TRITON STANDARD GUARANTEE

With the exception of accessories, Triton guarantee the product against all manufacturing defects for a period of **5 years** (for domestic use only) from the date of purchase, provided that it has been installed by a competent person in full accordance with the fitting instructions.

All accessories such as shower heads, hoses and riser rails carry a **1 year** parts only guarantee against manufacturing defects.

Any part found to be defective during this guarantee period we undertake to repair or replace at our option without charge so long as it has been properly maintained and operated in accordance with the operating instructions, and has not been subject to misuse or damage. This product must not be taken apart, modified or repaired except by a person authorised by Triton. This guarantee applies only to products installed within the United Kingdom and does not apply to products used commercially. This guarantee does not affect your statutory rights.

What is not covered:

1. Breakdown due to: *a)* use other than domestic use by you or your resident family; *b)* wilful act or neglect; *c)* any malfunction resulting from the incorrect use or quality of electricity, gas or water or incorrect setting of controls; *d)* failure to install in accordance with this installation guide
2. Claims for missing parts once the product has been installed.
3. Repair costs for damage caused by foreign objects or substances.
4. Total loss of the product due to non-availability of parts.
5. Compensation for loss of use of the product or consequential loss of any kind.
6. Call out charges where no fault has been found with the appliance.
7. The cost of repair or replacement of pressure relief devices, showerheads, hoses, riser rails and/or wall brackets, isolating switches, electrical cable, fuses and/or circuit breakers or any other accessories installed at the same time.
8. The cost of routine maintenance, adjustments, overhaul modifications or loss or damage arising therefrom, including the cost of repairing damage, breakdown, malfunction caused by corrosion, furring,
9. Call out charges where the water supply cannot be isolated, this includes consequential losses arising from unserviceable supply valves.

**For the latest Terms & Conditions, please see:
www.tritonshowers.co.uk**

Triton Showers
Triton Road
Nuneaton
Warwickshire CV11 4NR

Triton is a division of Norcros Group (Holdings) Limited

Customer Service: ☎ **0844 980 0750**

Trade Installer Hotline: ☎ **0844 980 0730**

Fax: **0844 980 0744**

www.tritonshowers.co.uk

E-mail: serviceenquiries@tritonshowers.co.uk