

**TRITON**

**T80si  
pumped  
electric shower**

**! IMPORTANT !**

Under **\*NO** circumstances must  
this shower be connected directly  
to a mains water supply.

It is designed for **GRAVITY FED  
COLD WATER** systems **ONLY !**

\*Failure to comply may invalidate product warranty



**Installation and  
operating  
instructions**



INSTALLERS PLEASE NOTE THESE INSTRUCTIONS ARE TO BE LEFT WITH THE USER

<b>CONTENTS</b>	<b>Page</b>
Important safety information .....	1
Introduction .....	2
Specifications.....	2
Advice to users .....	2
Main components .....	3
Electrical requirements.....	4
Water requirements .....	6
Siting of the shower .....	7
Fitting the shower to the wall.....	8
Plumbing connections .....	10
Electrical connections .....	11
Commissioning.....	12
Operating the shower.....	14
Operating functions.....	16
Instructions for installers and service engineers only .....	17 - 18
Spare parts .....	19
Fault finding .....	20 - 21
Guarantee, service policy, etc. ....	rear cover

To check the product suitability for commercial and multiple installations, please contact Triton's specification advisory service before installation.

Telephone: 0844 980 0730

Facsimile: 0844 980 0744

E mail: [technical@tritonshowers.co.uk](mailto:technical@tritonshowers.co.uk)

## PLEASE READ THIS IMPORTANT SAFETY INFORMATION

Products manufactured by Triton are safe and without risk provided they are installed, used and maintained in good working order in accordance with our instructions and recommendations.

- ⚠ WARNING: DO NOT** operate shower if frozen, or suspected of being frozen. It must thaw out before using.
- ⚠ DO NOT** operate the unit if the showerhead or spray hose becomes damaged.
- ⚠ DO NOT** restrict flow out of shower by placing showerhead in direct contact with your body.
- ⚠ DO NOT** operate the shower if water ceases to flow during use or if water has entered inside the unit because of an incorrectly fitted cover.
- ⚠ WARNING: If restarting the shower immediately after stopping, be aware that a slug of hot water will be expelled for the first few seconds.**

### 1 GENERAL

- 1.1** Isolate the electrical and water supplies before removing the cover.
- 1.2** Read all of these instructions and retain them for later use.
- 1.3 DO NOT** take risks with plumbing or electrical equipment.
- 1.4** Isolate electrical and water supplies before proceeding with the installation.
- 1.5** The unit must be mounted onto the finished wall surface (on top of the tiles). **DO NOT** tile up to or seal around **ANY PART** of the unit using silicone sealer after fixing to the wall. Special care must be taken **NOT TO BLOCK OR SEAL ANY PRD VENTS ON THE UNIT.**
- 1.6** Contact Customer Service (*see back page*), if any of the following occur:
  - a)** *If it is intended to operate the shower at pressures above the maximum or below the minimum stated.*
  - b)** *If the unit shows a distinct change in performance.*
  - c)** *If the shower is frozen.*
- 1.7** If it is intended to operate the shower in areas of hard water (above 200 ppm temporary hardness), a scale inhibitor may have to be fitted. For advice on the Scale Inhibitor, contact Customer Service.
- 1.8** The showerhead must be cleaned regularly with descaler to remove scale and debris, otherwise restrictions to the flow on the outlet of the unit will result in higher temperatures and could also cause the (PRD) Pressure Relief Device in the unit to operate.
- 1.9** This product is not suitable for mounting into steam rooms or steam cubicles.

### 2 PLUMBING

- 2.1** The plumbing installation must comply with Water Regulations, Building Regulations or any particular regulations as specified by Local Water Company or Water Undertakers and should be in accordance with BS 6700.

- 2.2** The supply pipe must be flushed to clear debris before connecting to the shower unit.
- 2.3 DO NOT** solder pipes or fittings within 300mm of the shower unit, as heat can transfer along the pipework and damage components.
- 2.4 DO NOT** fit any form of outlet flow control as the outlet acts as a vent for the heater can.
- 2.5 DO NOT** use excessive force when making connections to the flexible hose or showerhead, finger tight is sufficient.
- 2.6** All plumbing connections must be completed before making the electrical connections.

### 3 ELECTRICAL

- 3.1** The installation must comply with BS 7671 'Requirements for electrical installations' (IEE wiring regulations), building regulations or any particular regulations as specified by the local Electrical Supply Company.
- 3.2** This appliance **MUST** be earthed.
- 3.3** In accordance with 'The Plugs and Sockets etc. (Safety) Regulations 1994', this appliance is intended to be permanently connected to the fixed wiring of the electrical mains system.
- 3.4** Make sure all electrical connections are tight to prevent overheating.
- 3.5** A 30mA residual current device (RCD) **MUST** be installed in all UK electric and pumped shower circuits. This may be part of the consumer unit or a separate unit.
- 3.6** Switch off immediately at isolating switch if water ceases to flow during use.
- 3.7** Other electrical equipment i.e. extractor fans, pumps must not be connected to the circuits within the unit.
- 3.8** Switch off at isolating switch when not in use. This is a safety procedure recommended with all electrical appliances.

- 3.9** As with all electrical appliances it is recommended to have the shower and installation checked at least every two years by a competent electrician to ensure there is no deterioration due to age and usage.

## INTRODUCTION

This book contains all the necessary fitting and operating instructions for your electric shower. Please read them carefully and keep for future reference.

The shower installation must be carried out by a competent person and in the sequence of this instruction book.

DO NOT attempt any electrical or plumbing work necessary to install this product unless you have good practical experience and adequate understanding of the IEE regulations and water regulations.

Care taken during the installation will ensure a long, trouble-free life from your shower.

## SPECIFICATIONS

### Electrical

Nominal power rating at 240V	Nominal power rating at 230V
8.5kW – (40A MCB rating)	7.8kW – (40A MCB rating)
9.5kW – (40A MCB rating)	8.7kW – (40A MCB rating)

### Water

Inlet connection – 15 mm diameter.

Outlet connection – ½" BSP male thread.

### Entry Points

Water – **Left:** top, back, bottom.

Cable – **Left:** top, back, bottom.

### Materials

Backplate, cover, controls, showerhead – ABS.

Sprayplate – Acetal.

Elements – Minerally insulated corrosion resistant metal sheathing.

### Dimensions

Height – 365 mm

Width – 245 mm

Depth – 104 mm

### Standards and Approvals

Splashproof rating IPX4.

Complies with the requirements of current British and European safety standards for household and similar electrical appliances.

Complies with requirements of the British Electrotechnical Approvals Board (BEAB).

Meets with Compliance with European Community Directives (CE).

**IMPORTANT:** When first installed the unit will be empty. It is essential the unit should contain water before the elements are switched on. It is vital that the commissioning procedure is followed. Failure to carry out this operation will result in damage to the unit and will invalidate the guarantee.

## ADVICE TO USERS

The following points will help you understand how the shower operates:

- a. The electric heating elements operate at a constant rate at your chosen power setting. It is the flow rate of the water passing through the heater unit which determines the shower temperature at any given setting. (The slower the flow the hotter the water becomes, and the faster the flow the cooler the water).
- b. During the winter the cold water supply will be cooler than in the summer months. Therefore, the temperature of the water will vary from season to season on any one setting of the temperature control, e.g. if you have chosen 'medium' power for your preferred shower temperature in the summer, you may have to increase that to 'full' power during the winter months.
- c. If for any reason there is a sudden rise in water temperature, the shower has thermal cut-out device built-in (see items 3 and 4 under 'Fault Finding').
- d. If water ceases to flow switch off the shower at the start/stop button and the isolating switch. Contact Triton Customer Service for advice.

**If ever the water becomes too hot and you cannot obtain cooler water, first check that the sprayplate in the showerhead is not blocked.**

DO NOT place items such as soap or shampoo bottles on top of the unit. Liquid could seep through the joint between the cover and backplate, and possibly damage the sealing rubber.

Replacement parts can be ordered from Customer Service. See 'spare parts' for details and part numbers.

## MAIN COMPONENTS

### Inside unit (fig.1)

1. Top cable/pipe entry
2. Motor unit
3. Pump unit
4. Bleed screw
5. Wall screw fixing
6. Feed pipe
7. Thermal safety cut-out (main)
8. Terminal block
9. Can and element assembly
10. Power selector
11. Pressure switch
12. Temperature valve
13. Solenoid valve
14. Earth connection
15. Rear pipe / cable entry area
16. Inlet elbow
17. Outlet pipe
18. Filter

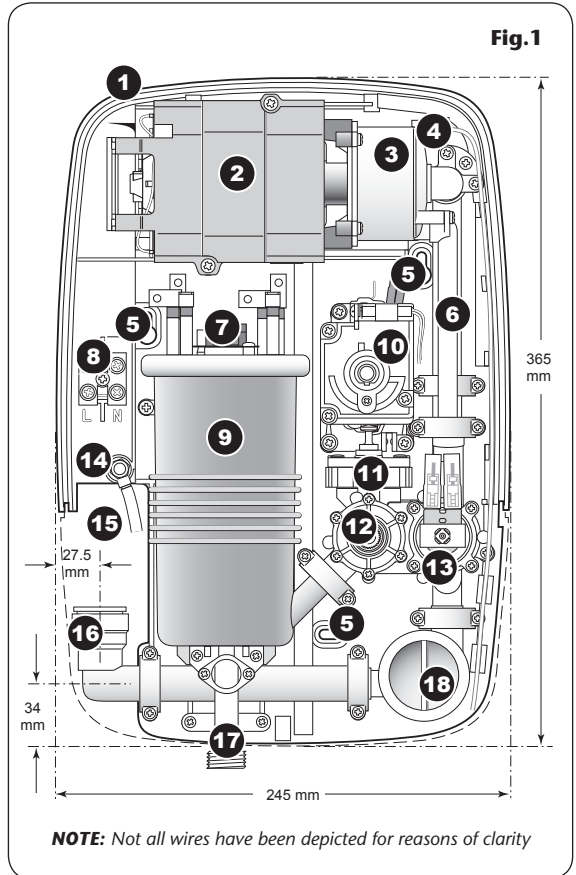

### Inside cover (fig.2)

19. Start/Stop switch

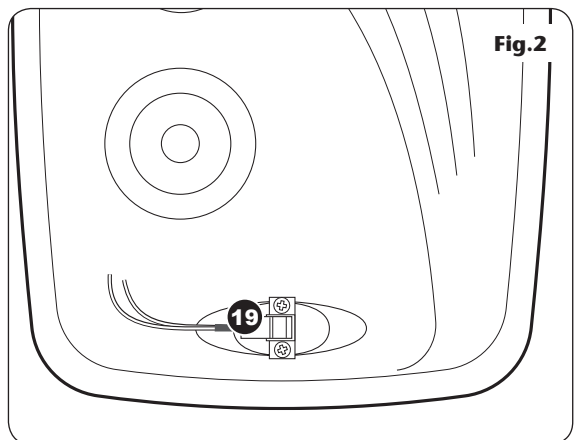

**ELECTRICAL REQUIREMENTS**

**WARNING!**  
**THIS APPLIANCE MUST BE EARTHED**

The installation, supply cable and circuit protection must conform with BS 7671 (IEE wiring regulations) and be sufficient for the amperage required.

The following notes are for guidance only:

- 1** The shower must only be connected to a 230-240V ac supply. If you are installing a shower with a kilowatt rating above 9kW, it is advisable to contact the local electricity supply company.
- 1.1** The electrical rating of the shower is shown on the rating label (**Fig.3**) within the unit.
- 2** Before making any sort of electrical connection within the installation make sure that no terminal is live. If in any doubt, switch off the whole installation at the mains supply and remove the correct fuse.
- 3** The shower must be connected to its own independent electrical circuit. IT MUST NOT be connected to a ring main, spur, socket outlet, lighting circuit or cooker circuit.
- 3.1** The electrical supply must be adequate for the loading of the unit and existing circuits.
- 4** Check your consumer unit (main fuse box) has a main switch rating of 80A or above and that it has a spare fuse way which will take the fuse or Miniature Circuit Breaker (MCB) necessary for the shower (**Fig.4**).
- 4.1** If your consumer unit has a rating below 80A or if there is no spare fuse way, then the installation will not be straightforward and may require a new consumer unit serving the house or just the shower.
- 4.2** You will need to contact the local electricity company. They will check the supply and carry out what is necessary.
- 5** For close circuit protection DO NOT use a rewireable fuse. Instead use a suitably rated Miniature Circuit Breaker (MCB) or cartridge fuse (**see Table A**).

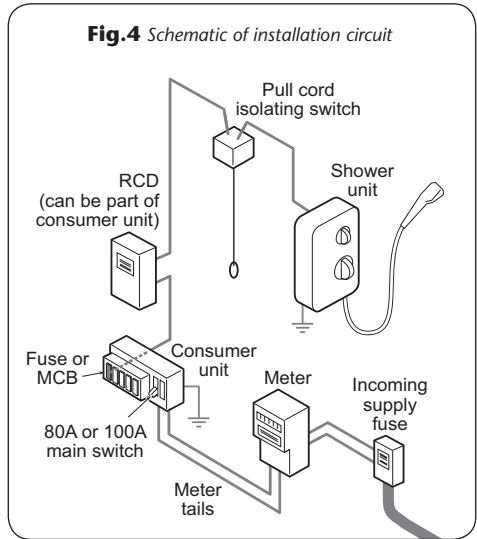
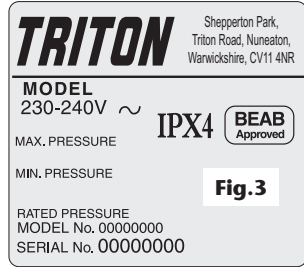

**Table A**

CIRCUIT PROTECTION		
unit rating	MCB	cartridge fuse
7.0kW	30/32A	30A
7.5kW	32A	35A
8.0kW	40A	35A
8.5kW	40A	45A
9.0kW	40A	45A
9.5kW	40/45A	45A
10.5kW	45A	45A

- 5.1 A 30mA residual current device (RCD) must be installed in all UK electric and pumped shower circuits. This may be part of the consumer unit or a separate unit.
- 6 A 45 amp double pole isolating switch with a minimum contact gap of 3 mm in both poles must be incorporated in the circuit.
- 6.1 It must have a mechanical indicator showing when the switch is in the OFF position, and the wiring must be connected to the switch without the use of a plug or socket outlet.
- 6.2 The switch must be accessible and clearly identifiable, but out of reach of a person using a fixed bath or shower, except for the cord of a cord operated switch, and should be placed so that it is not possible to touch the switch body while standing in a bath or shower cubicle. It should be readily accessible to switch off after using the shower.
- 7 Where shower cubicles are located in any rooms other than bathrooms, all socket outlets in those rooms must be protected by a 30mA RCD.
- 8 The current carrying capacity of the cable must be at least that of the shower circuit protection (**see Table B**).
- 8.1 To obtain full advantage of the power provided by the shower, use the shortest cable route possible from the consumer unit to the shower.
- 8.2 It is also necessary to satisfy the disconnection time and thermal constraints which means that for any given combination of current demand, voltage drop and cable size, there is a maximum permissible circuit length.
- 9 The shower circuit should be separated from other circuits by at least twice the diameter of the cable or conduit.
- 9.1 The current rating will be reduced if the cabling is bunched with others, surrounded by thermal loft or wall insulation or placed in areas where the ambient temperature is above 30°C. Under these conditions, derating factors apply and it is necessary to select a larger cable size.

- 9.2 In the majority of installations, the cable will unavoidably be placed in one or more of the above conditions. This being so, it is strongly recommended to use a minimum of 10mm cabling throughout the shower installation.
- 9.3 In any event, it is essential that individual site conditions are assessed by a competent electrician in order to determine the correct cable size and permissible circuit length.

**Table B**

<b>Twin and earth PVC insulated cable Current carrying capacity</b>		
<b>Installed in an insulated wall</b>	<b>In conduit trunking</b>	<b>Clipped direct or buried in a non-insulated wall</b>
6 mm <sup>2</sup> 32A	6 mm <sup>2</sup> 38A	6 mm <sup>2</sup> 46A
10 mm <sup>2</sup> 43A	10 mm <sup>2</sup> 52A	10 mm <sup>2</sup> 63A
16 mm <sup>2</sup> 57A	16 mm <sup>2</sup> 69A	16 mm <sup>2</sup> 85A
<b>Note: Cable selection is dependent on derating factors</b>		

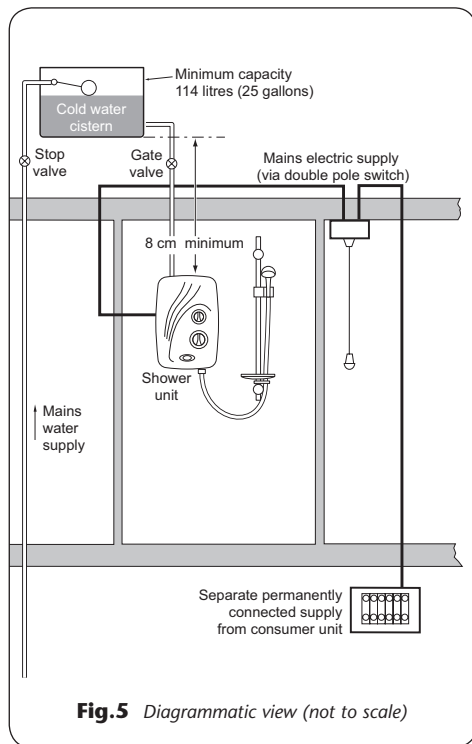

**Fig.5** Diagrammatic view (not to scale)

## WATER REQUIREMENTS

### WARNING!

**Under no circumstances must this T80si pumped shower be connected directly to the mains water supply.**

The installation must be in accordance with Water Regulations/Bylaws.

To guarantee activating the heating elements, the shower must be connected to a cold water supply which is gravity fed from a static cold water storage cistern with a minimum capacity of 114 litres (25 gallons).

There **MUST** be a maximum head of water of 10 metres and a minimum head of 8cm, as measured between the bottom of the cistern and the top of the shower unit.

There **MUST** be no other cold water draw-offs between the cistern and the unit and the pipe **MUST NOT** supply water to any other tap or fitting at a lower level.

**Note:** The supply pipe from the cistern should be on the opposite side to the float operated valve to prevent air being drawn into the pipe when the cistern is filling.

If it is intended to operate the shower in hard water areas (above 200 ppm temporary hardness) a scale inhibitor should be fitted.

**Fig.5** shows a typical system layout.

**DO NOT use jointing compounds on any pipe fittings for the installation.**



## SITING OF THE SHOWER

FOR EASE OF SERVICING, THE UNIT MUST ALWAYS BE MOUNTED ON THE SURFACE OF TILED WALLS. NEVER TILE UP TO THE UNIT.

Refer to **(Fig.6)** for correct siting of shower.

Position the unit where it will not be in direct contact with water from the showerhead.

Position the shower unit vertically.

Allow enough room between the ceiling and the shower to access the cover top screws.

### IMPORTANT: Water regulations

It is required that the showerhead be 'constrained by a fixed or sliding attachment so that it can only discharge water at a point not less than 25mm above the spill-over level of the relevant bath, shower tray or other fixed appliance'.

If the riser kit is supplied with a 'soapdish hose retainer' or bespoke 'hose retainer', it will in most cases meet this requirement. If the showerhead can still be placed within a bath, basin or shower tray within the 25mm limit, then a double check valve, or similar, **MUST** be fitted in the supply pipework to prevent back-flow.

### Pressure relief safety device

A pressure relief device (PRD) is designed into the shower unit which complies with European standards. The PRD provides a level of appliance protection should an excessive build up of pressure occur within the shower.

**Do not operate the shower with a damaged or kinked shower hose, or a blocked showerhead which can cause the PRD to operate.**

When commissioning, the showerhead must be removed from the flexible hose, while at the same time the temperature control must be at the minimum flow position. Failure to follow this procedure may also cause the PRD to operate.

Make sure the shower is positioned over a bath or shower tray because if the PRD operates, then water will eject from the bottom of the unit.

Should this happen, turn off the electricity and water supplies to the shower at the isolating switch and stopvalve. Contact Customer Service for advice on replacing the PRD.

### WARNING!

**The shower must not be positioned where it will be subjected to freezing conditions.**

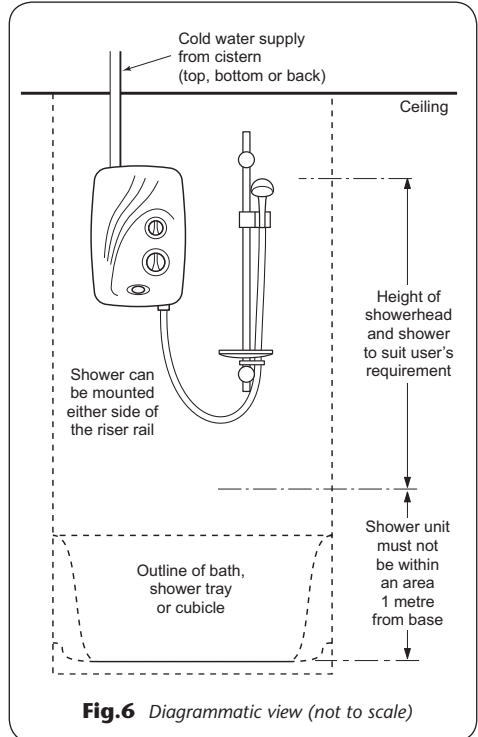

**Fig.6** Diagrammatic view (not to scale)

**IMPORTANT:** The unit must be mounted on a flat surface which covers the full width and length of the backplate. It is important that the wall surface is flat otherwise difficulty may be encountered when fitting the cover and subsequent operation of the unit may be impaired.



## FITTING THE SHOWER TO THE WALL

### WARNING!

**Check there are no hidden cables or pipes before drilling holes for wall plugs. Use great care when using power tools near water. The use of a residual current device (RCD) is recommended.**

**Note:** The control knobs are an integral part of the cover – DO NOT attempt to remove them.

**IMPORTANT:** The unit must be mounted on a flat surface which covers the full width and length of the backplate. It is important that the wall surface is flat otherwise difficulty may be encountered when fitting the cover and subsequent operation of the unit may be impaired.

Unscrew the two top and one bottom retaining screws (**fig.7**) and lift the cover from the backplate.

**Note:** Deviations from the designated entry points will invalidate product approvals.

If a top entry is required for the water pipe, remove the top cut-out in the backplate (**fig.8**) and rotate the inlet elbow so that it points upward. If a bottom entry is required for the cold water pipe, then a hole will need to be cut out of the cover (**fig.9**) and the inlet elbow rotated to face downward.

If entry is required from the back, rotate the inlet elbow upwards and fit the supplied elbow to connect to the pipe (**fig.10**).

Make sure the hole in which the pipe enters through the wall is filled in completely in order to stop any possible ingress of water into the cavity area.

After choosing the site for the shower, use the backplate as a template and mark the three fixing holes (**fig.11**).

Drill and plug the wall.

*(An appropriate drill bit should be used. If the wall is brick, plasterboard or a soft building block, appropriate wall plugs and screws should be fitted).*

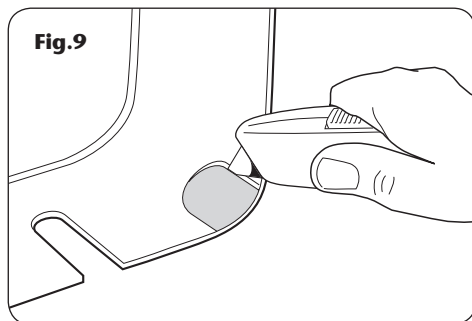
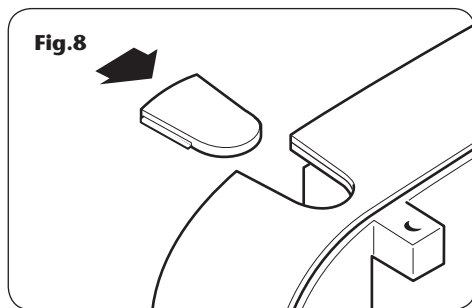

Screw two upper fixing screws into position leaving the base of the screw heads protruding 6 mm out from the wall.

Hook the backplate over the top screws and fit the lower fixing screw into position.

**DO NOT** fully tighten the screws at this stage, as the fixing holes are elongated to allow for out of square adjustment after the plumbing connections have been completed.

**Note:** A temporary factory fitted locking screw is fitted to the power selector spindle (**fig.12**). This is to make sure the spindle is held in the COLD position while the commissioning procedure is carried out. **DO NOT** remove the locking screw before this procedure is completed.

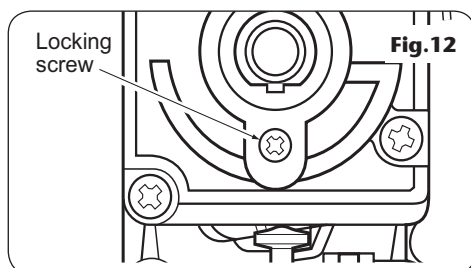
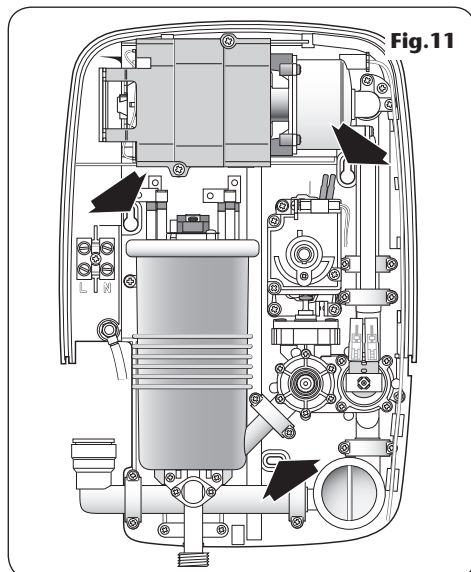
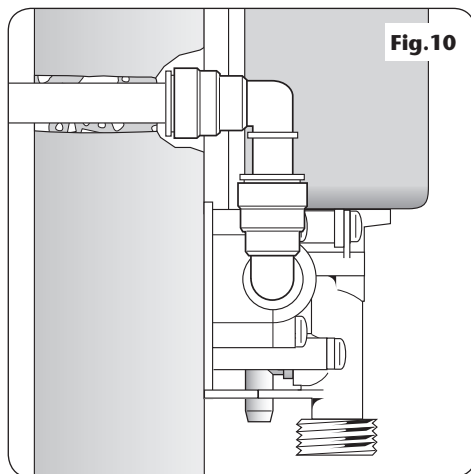

**WARNING!**

**The outlet of the shower acts as a vent and MUST NOT be connected to anything other than the hose and showerhead supplied.**

**IMPORTANT:** Before completing the connection of the water supply to the inlet of the shower, flush out the pipework to remove all swarf and system debris. This can be achieved by connecting a hose to the pipework and turning on the water supply long enough to clear the debris to waste.

**PLUMBING CONNECTIONS****Plumbing to be carried out before wiring**

**DO NOT** use jointing compounds on any pipe fittings for the installation.

**DO NOT** solder fittings near the shower unit as heat can transfer along the pipework and damage components.

**Note:** An additional gate valve or fullway lever valve **MUST** be fitted in the water supply to the shower as an independent means of isolating the water supply should maintenance or servicing be necessary.

**IMPORTANT:** The fitting on the inlet elbow is a push-in type. The pipework must be cut with a pipe cutter and all burrs and rough edges removed from the end of the tube. The fitting can be used with copper and plastic pipe.

If using chrome plated copper pipe, remove the first 25mm of plating completely from the connecting surface. If it is not completely removed then the collet will not grip the pipe and under pressure the pipe may be forced out.

**Procedure**

Turn off water supply either at the mains stopvalve or the isolating stopvalve to the cistern. Drain the cistern.

**IMPORTANT:** The pipework must be brought direct from the cold water storage cistern with no other cold water draw offs between the shower and the cistern.

Fit the pipework to the inlet elbow. Make sure the elbow collet is fully engaged with the pipe. Although the pipework connection to the shower is via 15mm diameter pipework, on long runs use 22mm diameter piping as far as possible to avoid restricting the flow to the shower.

Make sure that the backplate of the unit is flat on the wall and positioned squarely. Tighten the fixing screws.

Turn on the water supply and check for leaks in the pipework connection to the shower.

**IMPORTANT:** Using a suitable sealant, always seal around the incoming pipework to prevent water entering the wall.

**Note:** At this stage no water can flow through the unit.

## ELECTRICAL CONNECTIONS

SWITCH OFF THE ELECTRICITY SUPPLY AT THE MAINS.

**Fig.13** shows a schematic wiring diagram.

The cable entry points are shown in **fig.1**. The cable can be surface clipped, hidden or via 20mm conduit.

**Note:** Metal conduit entry can only be from rear.

Route the cable into the shower unit and connect to the terminal block (**fig.14**) as follows:

Earth cable to terminal marked **E** 

Neutral cable to terminal marked **N**

Live cable to terminal marked **L**

**IMPORTANT:** Fully tighten the terminal block screws and check that no cable insulation is trapped under the screws. Loose connections can result in cable overheating.

**Note:** The supply cable earth conductor must be sleeved. The outer sheath of the supply cable must be stripped back to the minimum.

The supply cable must be secured either by routing through conduit or in trunking or by embedding in the wall, in accordance with current IEE regulations.

The use of connections within the unit, or other points in the shower circuit, to supply power to other equipment i.e. extractor fans, pumps etc. will invalidate the guarantee.

### WARNING!

**Do not switch on the electricity supply until the commissioning procedure has been completed and the cover has been fitted. Failure to do so could cause the pump to run dry and invalidate the guarantee.**

**Fig.13**

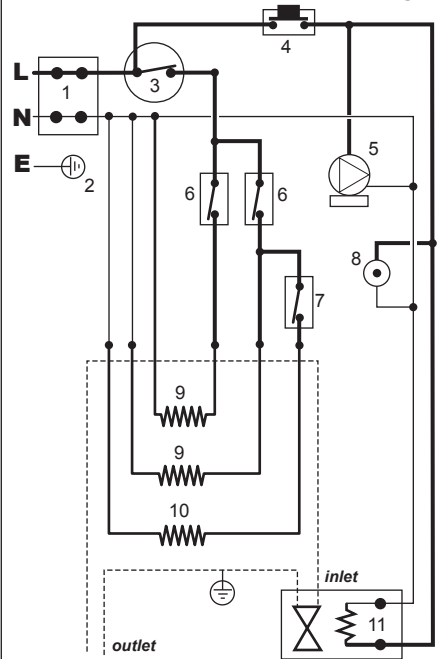

- |                           |  |
|---------------------------|--|
| 1. Terminal block         | 7. Microswitch (9.5kW)                 |
| 2. Earth post             | 8. Neon indicator                      |
| 3. Thermal cut-out (main) | 9. Elements (8.5kW)                    |
| 4. Start/Stop button      | 10. Element (additional for the 9.5kW) |
| 5. Pump and motor assy.   | 11. Solenoid valve                     |
| 6. Selector microswitches |  |

**Fig.14**

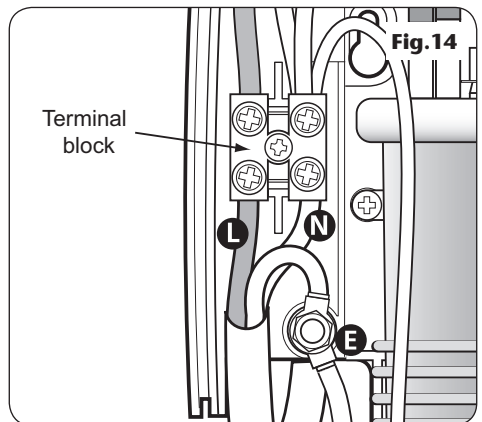

Fig. 15



Fig. 16



Fig. 17

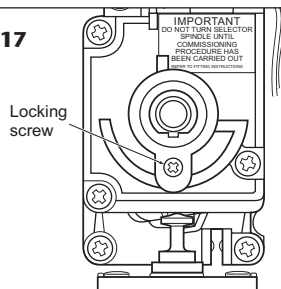
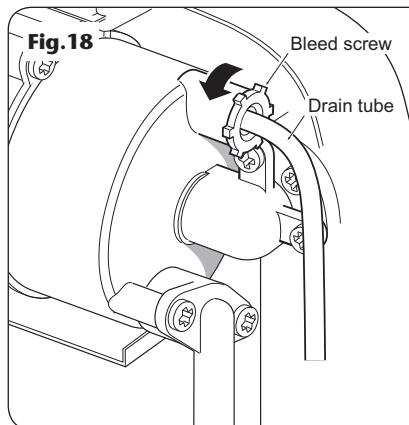

Fig. 18



## COMMISSIONING

### WARNING!

**Before normal operation of the shower, it is essential the following commissioning procedure is completed correctly.**

The first operation of the shower is intended to flush out any remaining unit debris, and to make sure the heater unit contains water before the elements are switched on.

This operation must be carried out with the flexible hose screwed to the outlet but **WITHOUT** the showerhead attached. Make sure the outlet of the flexible hose is directed to waste. The **COLD** position **MUST** be used.

To check that the temperature control is correctly positioned on the stabilising valve, temporarily place the cover in position so that the splines engage then rotate the temperature control fully anti-clockwise.

Remove the cover and position the temperature control so that it points towards '1' (**fig. 15**).

Position the power selector to the **COLD** position (**fig. 16**).

**DO NOT** remove the locking screw fitted to the power selector spindle (**fig. 17**) – it can be removed only when the commissioning procedure has been completed.

Make sure the water supply is still turned on to the shower.

Open the bleed screw on the pump unit (**fig. 18**) by rotating one revolution. When water flows from the drain pipe, this indicates that any trapped air is vented and that the pump unit is primed. The bleed valve must now be closed by rotating in the opposite direction.

Offer the cover to the backplate unit. Check that the power selector is still at the **COLD** position and the temperature control is at '1'.

**Note:** Check the START/STOP button is not depressed in the cover which indicates 'START'. The button should be flush with the cover, otherwise water will flow as soon as the electricity is switched on.

Attached to the START/STOP button inside the cover is a two-wire lead. The socket on the end of this lead must be connected to the plug that is situated at the bottom of the right-hand side of the backplate unit (**fig.19**).

**Note:** The plug and socket can only fit one way. Replace the cover squarely to the backplate and guide into position so that the controls locate correctly into the spindles while at the same time, checking the wires are not trapped above.

Secure the cover temporarily in position with the three retaining screws. **DO NOT OVERTIGHTEN.**

Switch on the mains electric supply to the shower at the isolating switch.

Press the START/STOP button (**fig.20**). The power indicator will light and the pump starts to operate.

It will take about thirty seconds for a smooth flow of water to be obtained while air and any debris is being flushed from the shower.

When a smooth flow of water is obtained, rotate the temperature control from '1' to '10' several times (**fig.21**) to release any trapped air within the unit.

Once flushing out has been completed, stop the water flow by pressing the START/STOP button.

**SWITCH OFF THE ELECTRICITY SUPPLY TO THE SHOWER AT THE ISOLATING SWITCH.**

Unscrew the three retaining screws again and lift the cover from the backplate.

Remove the locking screw from the power selector spindle (**fig.17**) and store for future use. Make sure the selector spindle is left in the same position.

Replace the cover as described above and permanently secure with the three retaining screws. **DO NOT OVERTIGHTEN.**

Switch the mains electric supply back on to the shower at the isolating switch. Once the riser rail is fitted, the shower is ready for normal use.

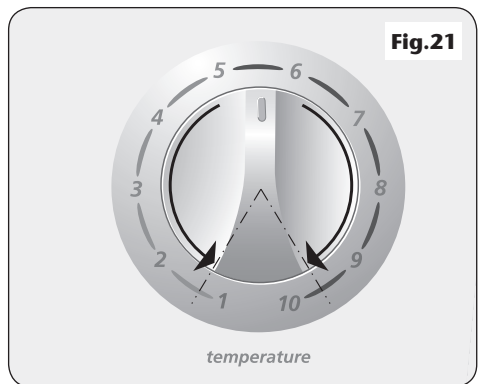
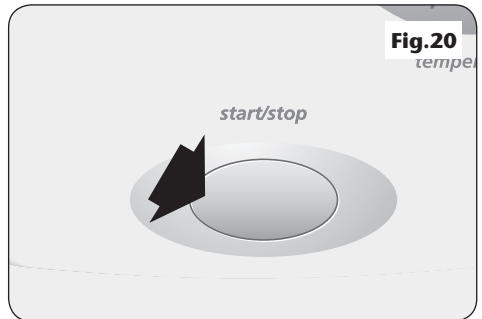
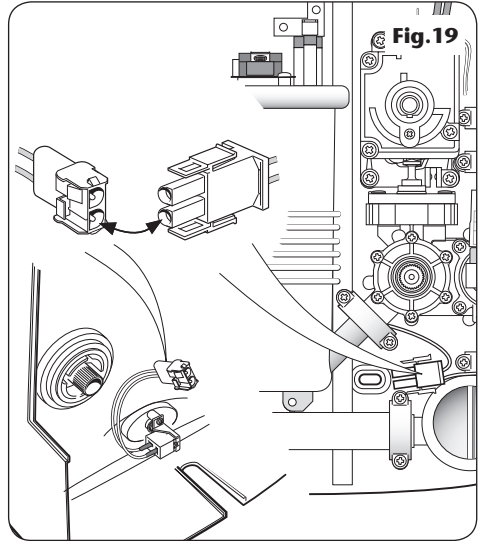



**Note:** In normal use, it is in order to leave the water supply permanently on to the shower unit, but as with most electrical appliances, **the unit must be switched off at the isolating switch when not in use.**

## OPERATING THE SHOWER

### WARNING!

**Before normal operation of the shower, it is essential the following commissioning procedure is completed correctly.**

### To start the shower

Pressing the START/STOP button (**fig.22**) switches on the pump allowing water to immediately flow through the unit.

### To stop the shower

Press the START/STOP button. This switches off the pump and the water flow will cease.

### WARNING!

**If restarting immediately after stopping, be aware that a slug of hot water will be expelled for the first few seconds.**

### To use the power selector

The power selector (**fig.22**) has four settings — COLD, LOW, MEDIUM and FULL POWER.

**Blue symbol** is for COLD water only. Adjusting the temperature control at this setting will only increase or decrease the force of the water from the showerhead. It will not alter the water temperature.

**Red outline symbol** is the LOW setting for extra economy during hot months. Temperature adjustment at this setting is via the temperature control.

**Single red symbol** is the MEDIUM setting for economy during warmer months and any temperature adjustment at this setting is via the temperature control.

**Double red symbol** is FULL power setting which allows the highest flow achievable for your preferred temperature. Temperature adjustment at this setting is via the temperature control.



### **To adjust the shower temperature**

The shower temperature is altered by increasing or decreasing the flow rate of the water through the shower via the temperature control.

After obtaining your preferred shower temperature, the number can be remembered as the normal setting and should only need to be altered to compensate for seasonal changes in ambient water temperatures.

### **To decrease the shower temperature**

Turn the temperature control anti-clockwise towards the lower numbers; this will increase the water flow.

### **To increase the shower temperature**

Turn the temperature control clockwise towards the higher numbers; this will decrease the water flow.

**Note:** Be certain the showering temperature is satisfactory by testing with your hand before stepping under the showerhead. There will always be a time delay of a few seconds between selecting a flow rate and the water reaching the stable temperature for that flow rate.

**CAUTION:** It is recommended that persons who may have difficulty understanding or operating the shower controls should not be left unattended while showering. Special consideration should be given to young children and the less able bodied.

#### **WARNING!**

**After any servicing of mains water supply, always flush out the pipework to remove any debris.**

**Always make sure the unit is started on COLD in order to purge any air in the pipework.**

#### **WARNING**

**This appliance is not intended for use by persons (including children) with reduced physical, sensory or mental capabilities, or lack of experience and knowledge, unless they have been given supervision or instruction concerning use of the appliance by a person responsible for their safety.**

**Children should be supervised to ensure that they do not play with the appliance.**

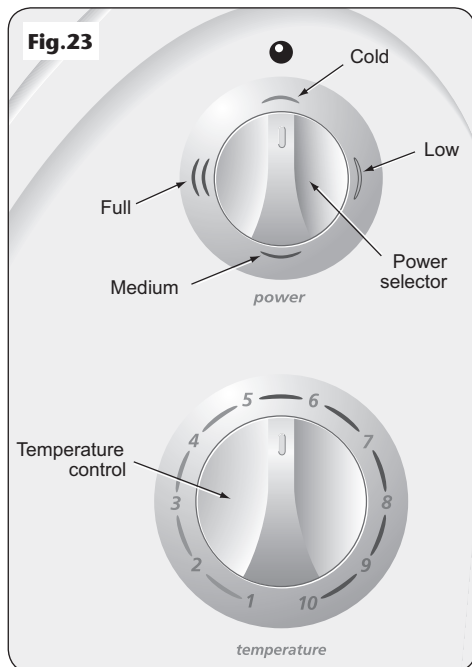

**WARNING!**  
**DO NOT use abrasive or aggressive cleaning products when cleaning the shower as they may damage the unit.**

## OPERATING FUNCTIONS

### **Power on indicator (fig.23)**

The power neon will light when the START/STOP button is pressed. This indicates that power is on to the pump and power selector.

### **Low water pressure cut-out**

Should the water pressure fall below the minimum required to operate the shower, power will be switched off to the heating elements preventing any maintained temperature rises.

### **Overheat cut-out**

During normal operation if an overheat temperature is sensed, power to the elements will be removed. Water will continue to flow. When the temperature has cooled sufficiently, power to the elements will be automatically restored to the previous setting at the time of interruption.

### **Safety cut-out**

The unit is fitted with a non-resettable over-temperature safety device. In the event of abnormal operation which could cause unsafe temperatures within the unit, the device will disconnect the heating elements. It will require a visit from a qualified engineer to determine the nature of the fault and replace the safety device, once the unit has been repaired.

**INSTRUCTIONS FOR INSTALLERS AND SERVICE ENGINEERS ONLY****CLEANING THE INLET FILTER**

It is recommended that the filter is periodically cleaned in order to maintain the performance of the shower. It is essential that this operation is carried out by a competent person.

**SWITCH OFF THE ELECTRICITY SUPPLY AT THE MAINS.**

Remove the cover and disconnect the plug.

There is no need to turn off the water supply — the act of removing the filter unit automatically isolates the water supply.

**Note:** Should debris be trapped on the shut off seat inside the valve, water will continue to flow out as the filter is removed. It is therefore advisable to locate the main isolating valve before removing the filter in the event that the unit needs isolating.

DO NOT rely on the filter shut off valve when carrying out repairs or service to other areas of the shower unit.

Unscrew the filter (**fig.24**) by turning anti-clockwise. Remove the unit complete with the filter and wash under running water. Make sure all debris, etc. is removed.

Replace by pushing the unit back into its housing until the threads engage and then turn fully clockwise until tight. DO NOT OVERTIGHTEN.

Before replacing the cover, it is strongly advised to prime the unit by opening the bleed screw until water drains from it.

Close the bleed screw and connect the plug to the cover. Replace the cover and secure with the fixing screws.

Switch on the electric supply and start the shower on the COLD SETTING ONLY and with the temperature control rotated fully anti-clockwise.

When a smooth flow of water is obtained, the shower can then be used in the normal manner.

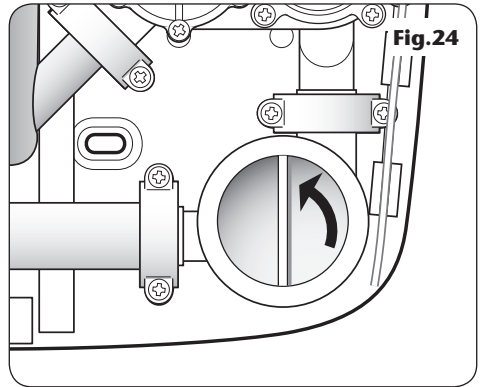

**INSTRUCTIONS FOR INSTALLERS AND SERVICE ENGINEERS ONLY**

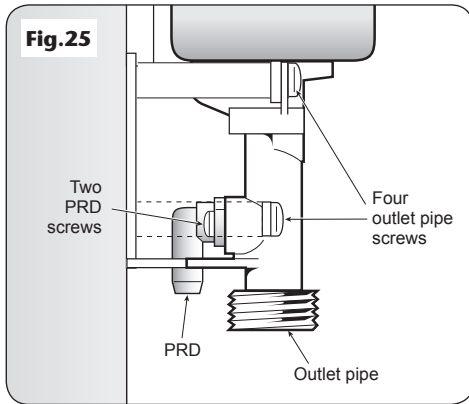

**REPLACING THE PRD**

The PRD is situated behind the outlet pipe (**fig.25**). To access the PRD, **FIRST SWITCH OFF THE ELECTRICITY SUPPLY**, then unscrew the hose and remove the cover.

Remove the four screws securing the outlet pipe in position. Carefully pull away from the can and then unscrew the two screws holding the PRD to the outlet pipe.

**CAUTION: DO NOT attempt to replace the PRD unless competent to do so.**

**Note:** Before replacing the cover, it is strongly advised to prime the unit (see 'commissioning').

**SPARE PARTS**

<b>Ref. Description</b>	<b>Part No.</b>
<b>1.</b> Motor and pump assembly.....	84000120
<b>2.</b> Connecting pipe – rear A.....	7052554
Connecting pipe – rear B.....	7052555
<b>3.</b> Thermal cut-out.....	22012680
<b>4.</b> Terminal block & wires	
8.5kW .....	82201170
9.5kW .....	82201160
<b>5.</b> Can assembly	
8.5kW (240V).....	84500810
9.5kW (240V).....	84500800
<b>6.</b> Selector switch including microswitch and wire assembly	
8.5kW .....	82500260
9.5kW .....	82500270
<b>7.</b> Connecting pipe.....	7052556
<b>8.</b> Flow valve assembly.....	82100300
including solenoid	
<b>9.</b> Filter .....	82800620
<b>10.</b> Inlet pipe assembly .....	82800600
<b>11.</b> Outlet pipe .....	83314640
<b>12.</b> Cover assembly.....	84900030
c/w knobs & button	
– Pipe trims (top).....	7052562
– Neon .....	82300940
– Motor live wire .....	82301400
– Motor neutral wire.....	82301410
– Pressure relief device.....	82800450
– 15mm John Guest stem elbow.....	22008180
– Start/stop switch.....	82301310

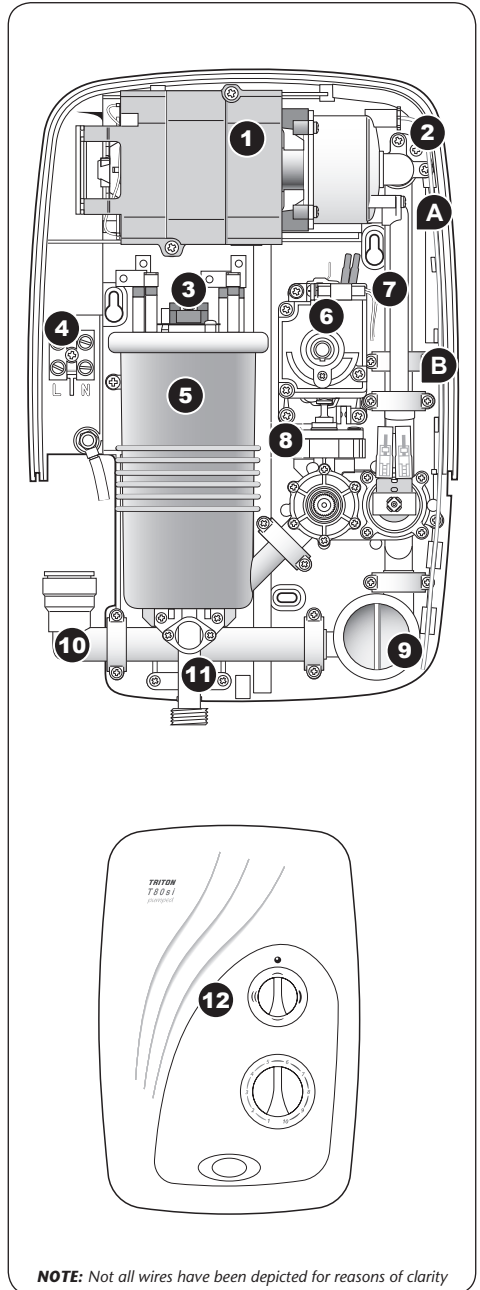

**FAULT FINDING**

**IMPORTANT:** Switch off the electricity at the mains supply and remove the circuit fuse before attempting any fault finding inside the unit.

<b>Problem/Symptom</b>	<b>Cause</b>	<b>Action/Cure</b>
<b>1</b> Shower inoperable, no water flow when the Start/Stop button is pressed.	<b>1.1</b> Interrupted power supply.	<b>1.1.1</b> Check if a general power cut. Check other appliances and if necessary, contact the local Electricity Supply Company. <b>1.1.2</b> If the power neon does not illuminate when the Start/Stop button is pressed, check the consumer unit fuse or circuit breaker or isolating switch. If blown or faulty, renew or reset as applicable. If it fails again, consult a competent electrician.
	<b>1.2</b> Plug not connected to socket inside the cover.	<b>1.2.1</b> Remove the cover and ensure the plug and socket are firmly connected.
	<b>1.3</b> Solenoid valve malfunction.	<b>1.3.1</b> Have solenoid checked by a competent electrician or contact Customer Service.
	<b>1.4</b> Pump motor faulty.	<b>1.4.1</b> If the power neon is lit when the Start/Stop button is pressed, have the pump checked by a competent person or contact Customer Service.
<b>2</b> Water too hot.	<b>2.1</b> Not enough water flowing through the shower.	<b>2.1.1</b> Increase the flow rate via temp control. <b>2.1.2</b> Blocked showerhead – clean or replace showerhead. <b>2.1.3</b> Blocked filter – see ‘filter maintenance’.
	<b>2.2</b> Increase in ambient water temperature.	<b>2.2.1</b> Switch to reduced power setting and readjust flow rate (via temperature control) to give the required temperature.
	<b>3.1</b> Heater cycling on outlet thermal cut-out.	<b>3.1.1</b> See ‘Water too hot’ causes 2.1 and 2.2 and their appropriate action/cures. If it continues, contact Triton Customer Service.
<b>3</b> Water temperature cycling hot/cool at intervals.	<b>3.1</b> Heater cycling on outlet thermal cut-out.	<b>3.1.1</b> See ‘Water too hot’ causes 2.1 and 2.2 and their appropriate action/cures. If it continues, contact Triton Customer Service.
	<b>4.1</b> Too much flow.	<b>4.1.1</b> Reduce the flow rate via the temperature control.
	<b>4.2</b> Reduction in the ambient water temperature.	<b>4.2.1</b> Switch to full power setting and readjust the flow rate via the temperature control to give the required temperature.
<b>4</b> Water too cool or cold.	<b>4.3</b> Electrical malfunction or safety cut-out has operated.	<b>4.3.1</b> Have shower unit checked by a competent electrician or contact Customer Service.

## FAULT FINDING

<b>Problem/Symptom</b>	<b>Cause</b>	<b>Action/Cure</b>
<b>5</b> During use, the water flow ceases abruptly.	<b>5.1</b> Interrupted power supply.	<b>5.1.1</b> See 1.1.1 and 1.1.2.
	<b>5.2</b> Solenoid valve malfunction (pump still operates).	<b>5.2.1</b> Switch off immediately. Have solenoid checked by a competent electrician or contact Customer Service.
	<b>5.3</b> Pump motor faulty.	<b>5.3.1</b> See 1.5.1.
<b>6</b> Shower performance drops indicated by a gradual reduction in water flow.	<b>6.1</b> Water starvation to the unit.	<b>6.1.1</b> Check the filter is not blocked. First, isolate the electricity supply and then remove the cover.
		<b>6.1.2</b> Check the cold water cistern is full.
		<b>6.1.3</b> Make sure the water supply pipe is not blocked or air locked.
		<b>6.1.4</b> Check there is no simultaneous demand from the cistern during showering.
		<b>6.1.5</b> Reprime the unit without electricity switched on to the unit (see 'commissioning' section).
<b>7.</b> Pressure relief device has operated (water ejected from PRD tube).	<b>7.1</b> Blocked showerhead.	<b>7.1.1</b> Clean or replace blocked cartridge in the showerhead and then fit a new PRD.
	<b>7.2</b> Twisted/blocked flexible shower hose.	<b>7.2.1</b> Check for free passage through the hose. Replace the hose if necessary and then fit a new PRD.
	<b>7.3</b> Showerhead not removed while commissioning.	<b>7.3.1</b> Fit a new PRD. Commission the unit with showerhead removed.

**Note:** Identify cause of operation before fitting new PRD unit. When fitting a new PRD, follow the commissioning procedure.

**It is advised all electrical maintenance/repairs to the shower should be carried out by a suitably qualified person.**



## UK SERVICE POLICY

In the event of a product fault or complaint occurring, the following procedure should be followed:

1. Telephone Customer Service on **0844 980 0750** having available, your details including post code, the model number and power rating of the product, together with the date of purchase and, where applicable, details of the particular fault.
2. If required, the Customer Service Advisor will arrange for a qualified engineer to call.
3. All products attended to by a Triton service engineer must be installed in full accordance with the Triton installation guide applicable to the product. *(Every product pack contains an installation guide, however, they can also be bought via our Customer Service Spares Department).*
4. Our engineer will require local parking and if a permit is required this must be available to the engineer on arrival at the call.
5. It is essential that you or an appointed representative (*who must be over 18 years of age*) is present for the duration of the service engineer's visit. If the product is in guarantee you must produce proof of purchase.
6. Where a call under the terms of guarantee has been booked and the failure is not product related (*i.e. scaling and furring, incorrect water pressure, pressure relief device operation or electrical/plumbing installation fault*) a charge will be made. A charge will also be issued if nobody is at home when the service engineer calls or adequate parking/permit is not available.
7. If the product is no longer covered by the guarantee an up front fixed fee will be charged before the site visit.
8. Should proof of purchase not be available on an "in-guarantee" call, or should the service engineer find that the product is no longer under guarantee, the engineer will charge the same fixed price and the customer will be expected to pay the engineer before he leaves. If payment is not made on the day an administration charge will be added to the fixed charge.
9. If a debt is outstanding from a previous visit, or from any other Triton purchase. Triton reserves the right to withhold service until the debt has been settled.
10. Triton takes the health, safety and wellbeing of its employees very seriously and expects customers to treat all staff members with respect. Should any employee feel threatened or receive abuse, either verbally or physically, Triton reserves the right to withhold service and will support the employee with a legal prosecution.

## Replacement Parts Policy

It is the policy of Triton Showers to maintain parts availability for the duration of production and a period of 5 years thereafter in accordance with industry standards. In the event of a spare part not being available a substitute part will be supplied.

Spare parts can be ordered via our online spare parts store, or by telephoning Triton Spares Department. Payment should be made by credit/debit card (*excluding American Express or Diners Card*). Payment can also be made by pre-payment of a pro-forma invoice, by cheque or postal order.

Telephone orders are based on information given during of the call. Before contacting Triton, please verify your requirements using the information contained in the user guide. Triton cannot accept liability for incorrect part identification.

## TRITON STANDARD GUARANTEE

Triton guarantee this product against all mechanical and electrical defects arising from faulty workmanship or materials for a period of one year for domestic use only, from the date of purchase, provided that it has been installed by a competent person in full accordance with the fitting instructions.

Any part found to be defective during this guarantee period we undertake to repair or replace at our option without charge so long as it has been properly maintained and operated in accordance with the operating instructions, and has not been subject to misuse or damage.

This product must not be taken apart, modified or repaired except by a person authorised by Triton. This guarantee applies only to products installed within the United Kingdom and does not apply to products used commercially. This guarantee does not affect your statutory rights.

### What is not covered:

1. Breakdown due to: **a)** use other than domestic use by you or your resident family; **b)** wilful act or neglect; **c)** any malfunction resulting from the incorrect use or quality of electricity, gas or water or incorrect setting of controls; **d)** failure to install in accordance with this installation guide.
2. Repair costs for damage caused by foreign objects or substances.
3. Total loss of the product due to non-availability of parts.
4. Compensation for loss of use of the product or consequential loss of any kind.
5. Call out charges where no fault has been found with the appliance.
6. Call out charges where the water supply cannot be isolated, this includes consequential losses arising from unserviceable supply valves.
7. The cost of repair or replacement of pressure relief devices, showerheads, hoses, riser rails and/or wall brackets, isolating switches, electrical cable, fuses and/or circuit breakers or any other accessories installed at the same time.
8. The cost of routine maintenance, adjustments, overhaul modifications or loss or damage arising therefrom, including the cost of repairing damage, breakdown, malfunction caused by corrosion, furring, pipe scaling, limescale, system debris or frost.

**Customer Service:** ☎ **0844 980 0750**

**Trade Installer Hotline:** ☎ **0844 980 0730**

**Fax:** **0844 980 0744**

**www.tritonshowers.co.uk**

**E-mail:** [serviceenquiries@tritonshowers.co.uk](mailto:serviceenquiries@tritonshowers.co.uk)

Triton Showers  
Triton Road  
Nuneaton  
Warwickshire CV11 4NR

*Triton is a division of Norcros Group (Holdings) Limited*

**Extended Warranty AVAILABLE NOW. Call 0844 980 0740 for more details.**