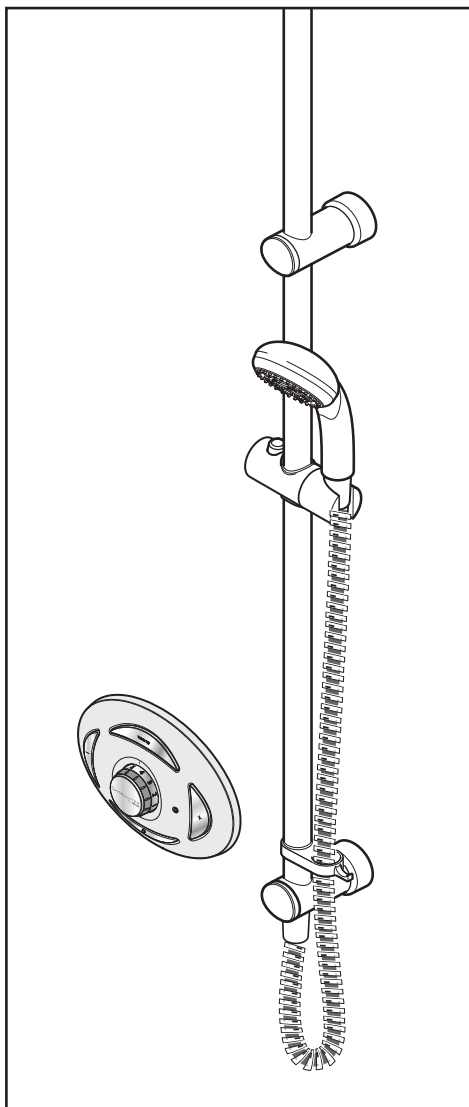


SATELLITES  
by TRITON

**TRITON**

# SATELLITES

High performance  
mixer shower with  
remote control



## Installation instructions

INSTALLERS PLEASE NOTE THESE INSTRUCTIONS ARE TO BE LEFT WITH THE USER

### UK SERVICE POLICY

In the event of a product fault or complaint occurring, the following procedure should be followed:

1. Telephone Customer Service on **0844 980 0750** having available, your details including post code, the model number and power rating of the product, together with the date of purchase.
2. Based on information given over the telephone, a Triton Customer Service Advisor will attempt to diagnose the fault and confirm whether a site visit from a qualified service engineer is required.
3. All products attended to by a Triton service engineer must be installed in full accordance with the Triton installation guide applicable to the product. *(Every product pack contains an installation guide, however, they can also be bought via our Customer Service Spares Department).*
4. Our engineer will require local parking and if a permit is required this must be available to the engineer on arrival at the call.
5. It is essential that you or an appointed representative (*who must be over 18 years of age*) is present for the duration of the service engineer's visit. If the product is in guarantee you must produce proof of purchase.
6. Where a call under the terms of guarantee has been booked and the failure is not product related (*i.e. scaling and furring, incorrect water pressure, pressure relief device operation or electrical/plumbing installation fault*) a charge will be made. A charge will also be issued if nobody is at home when the service engineer calls or adequate parking/permit is not available.
7. If the product is no longer covered by the guarantee an up front fixed fee will be charged before the site visit.
8. Should proof of purchase not be available on an "in-guarantee" call, or should the service engineer find that the product is no longer under guarantee, the engineer will charge the same fixed price and the customer will be expected to pay the engineer before he leaves. If payment is not made on the day an administration charge will be added to the fixed charge.
9. If a debt is outstanding from a previous visit, or from any other Triton purchase. Triton reserves the right to withhold service until the debt has been settled.
10. Triton takes the health, safety and wellbeing of its employees very seriously and expects customers to treat all staff members with respect. Should any employee feel threatened or receive abuse, either verbally or physically, Triton reserves the right to withhold service and will support the employee with a legal prosecution.

### Replacement Parts Policy

**Availability:** It is the policy of the manufacturer to maintain parts availability for the duration of production and a period of five years thereafter, in accordance with industry standards.

Spare parts are available via our website, [www.tritonshowers.co.uk](http://www.tritonshowers.co.uk), or by telephoning Triton Customer Service Spares Department. Payment should be made by credit/debit card (*excluding American Express or Diners Card*).

Payment can also be made by pre-payment of a pro forma invoice by cheque or money order.

### TRITON STANDARD GUARANTEE

Triton guarantee this product against all mechanical defects arising from faulty workmanship or materials for a period of five years for domestic use only, from the date of purchase, provided that it has been installed by a competent person in full accordance with the fitting instructions.

Any part found to be defective during this guarantee period we undertake to repair or replace at our option without charge so long as it has been properly maintained and operated in accordance with the operating instructions, and has not been subject to misuse or damage.

This product must not be taken apart, modified or repaired except by a person authorised by Triton. This guarantee applies only to products installed within the United Kingdom and does not apply to products used commercially. This guarantee does not affect your statutory rights.

#### What is not covered:

1. Breakdown due to: **a)** use other than domestic use by you or your resident family; **b)** wilful act or neglect; **c)** any malfunction resulting from the incorrect use or quality of electricity, gas or water or incorrect setting of controls; **d)** failure to install in accordance with this installation guide.
2. Repair costs for damage caused by foreign objects or substances.
3. Total loss of the product due to non-availability of parts.
4. Compensation for loss of use of the product or consequential loss of any kind.
5. Call out charges where no fault has been found with the appliance.
6. Call out charges where the water supply cannot be isolated, this includes consequential losses arising from unserviceable supply valves.
7. The cost of repair or replacement of pressure relief devices, showerheads, hoses, riser rails and/or wall brackets, isolating switches, electrical cable, fuses and/or circuit breakers or any other accessories installed at the same time.
8. The cost of routine maintenance, adjustments, overhaul modifications or loss or damage arising therefrom, including the cost of repairing damage, breakdown, malfunction caused by corrosion, furring, pipe scaling, limescale, system debris or frost.

Triton Showers  
Triton Road  
Nuneaton  
Warwickshire CV11 4NR

*Triton is a division of Norcros Group (Holdings) Limited*

**Customer Service:** ☎ **0844 980 0750**

**Trade Installer Hotline:** ☎ **0844 980 0730**

**Fax:** **0844 980 0744**

[www.tritonshowers.co.uk](http://www.tritonshowers.co.uk)

**E-mail:** [serviceenquiries@tritonshowers.co.uk](mailto:serviceenquiries@tritonshowers.co.uk)

<b>CONTENTS</b>	<b>Page</b>
Guarantee, service policy, etc. ....	Inside cover
Contents .....	1
Plumbing and electrical general notes .....	2
Introduction .....	3
Standards and approvals.....	3
Site requirements .....	3
Specifications .....	4
General installation notes .....	5
Main components .....	6 – 7
Typical suitable installations .....	8 – 10
Siting options .....	11
Positioning the mixing unit .....	12
Fitting the mixing unit .....	13
*Riser rail installation options .....	14 – 16
*Installation option 1: Rear entry supply .....	16 – 17
*Installation option 2: Falling supplies – through the ceiling riser rail (short) .....	18 – 20
*Installation option 3: Falling supplies – through the ceiling riser rail (long) .....	21 – 24
Incoming plumbing connections.....	25 – 26
Outgoing plumbing connections.....	27 – 28
*Fitting the showerhead .....	29
Electrical connections.....	30
Registering the shower unit.....	31
Commissioning .....	32 – 33
Installing the control panel.....	34

## 1 PLUMBING NOTES

- 1.1** All installations must comply with Water Regulations or Water Bylaws.
- 1.2** Supply pipes must be flushed to clear debris before connecting the mixing unit.
- 1.3** Layout and sizing of pipework MUST be such that when other services are used, pressures at the shower control inlets DO NOT fall below the recommended minimum.
- 1.4** DO NOT use excessive force when making connections to the mixing unit.
- 1.5** DO NOT choose a position where the shower will become frozen.
- 1.6** DO NOT connect this mixing unit to any form of tap or fitting not recommended by the manufacturer.
- 1.7** The showerhead or other approved Triton device MUST be regularly cleaned to remove scale and debris.
- 1.8** If it is intended to operate the shower in areas of hard water (above 200 ppm temporary hardness), a scale inhibitor may have to be fitted. For advice on the Triton scale inhibitor, please contact Customer Service.
- 1.9** DO NOT operate the mixing unit outside the guidelines as laid out in '*site requirements*' and '*specifications*'.

### Low pressure unit only

- 1.10** DO NOT connect the low pressure mixing unit to the mains water supply as this would damage the unit.
- 1.11** When installed, the top of the low pressure mixing unit must be at least 100 mm lower than the base of the cold water cistern to prevent the unit running dry.
- 1.12** A dedicated cold water supply must be taken directly from the cold water cistern to the mixing unit. This draw-off must be on the opposite side of the cistern to the float operated valve to reduce the risk of air entering the unit.

- 1.13** The cold water cistern should hold at least 115 litres (25 gallons). If other outlets are served from the cistern the capacity should be increased to 230 litres (30 gallons).
- 1.14** Do not connect to a combination cylinder unless the minimum cold storage can be achieved as the shower can deliver up to 16 litres/min.
- 1.15** The infill to the cistern should be checked to ensure an adequate infill rate occurs.

## 2 ELECTRICAL NOTES

- 2.1** The installation must comply with BS 7671 'Requirements for electrical installations' (IEE wiring regulations). Make sure metal incoming hot and cold water supplies to the mixing unit are adequately earth bonded.
- 2.2** DO NOT turn on the electrical supply until the plumbing connections have been completed. Only then can the electricity be switched on in order to power the solenoid to turn water on to the mixing unit when commissioning. The mixing unit must not be operated dry without water.
- 2.3** The mains supply must be 230/240V, at 50Hz, connected to the unit via a 5 Amp fused connection unit (not supplied).
- 2.4** In accordance with 'The Plugs and Sockets etc. (Safety) Regulations 1994', this unit is intended to be permanently connected to the fixed electrical wiring of the mains system. All external connections must be safely secured.  
  
If the mixer is to be installed within a bath or shower room the electrical installation MUST conform to Part P Building Regulation Requirements for Special Locations.

## INTRODUCTION

This book contains all the necessary installation instructions for your mixing unit – please read them carefully.

The shower installation must be carried out by a suitably qualified person and in the sequence of this instruction book.

Care taken during the installation will provide a long, trouble-free life from your shower.

The shower **MUST NOT** be subjected to water temperatures above 65°C.

The low pressure mixing unit is designed for use with a traditional low pressure 'gravity' system, using a cold water cistern and hot water cylinder, up to a maximum of 100kPa (1 bar) running pressure.

The high pressure mixing unit is designed for use with high pressure systems up to a maximum of 500kPa (5 bar) running pressure. The mixing unit is suitable for fully modulating type combination boilers and multipoint hot water heaters. It is also suitable for thermal storage and unvented systems.

**IMPORTANT:** Before installing with a gas instantaneous water heater, make sure it is capable of delivering hot water at a minimum switch-on flow rate of 3 litres per minute. At flow rates between 3 and 8 litres per minute, the appliance must be capable of raising the water temperature to a minimum of 52°C. Water temperature at the mixer inlet must remain relatively constant when flow rate adjustments are made (*refer to the water heater operating manual to confirm compatibility with this mixer shower*).

Replacement parts can be ordered from Triton Customer Service. See 'spare parts' for details.

## STANDARDS AND APPROVALS

The mixing unit is an independently mounted electronic control.

Complies with the requirements of current British and European safety standards for household and similar electrical appliances.

Meets with Compliance with European New Approach Directives (CE).

Complies with the requirements of the Radio Equipment and Telecommunications Terminal Equipment (RTTE) Directive 1999/5/EC.

Pollution degree	2
Rated impulse voltage	2.5 kV
Suitable for drinking?	Not suitable

## SITE REQUIREMENTS

The installation must be in accordance with Water Regulations and Bylaws.

DO NOT connect the mixing unit to a gravity hot supply and a mains cold supply (or vice versa).

The pipework should be installed such that the flow is not significantly affected by other taps and appliances being operated elsewhere on the premises.

BS 6700 recommends that the temperature of stored water should never exceed 65°C.

A stored water temperature of 60°C is considered sufficient to meet all normal requirements and will minimise the effects of scale in hard water areas.

## SPECIFICATIONS

	Low pressure unit	High pressure unit
<b>Duty cycle</b>	30 minutes on 30 minutes off	30 minutes on 30 minutes off
<b>Electrical</b>		
Mains supply	230V 50Hz	230V 50Hz
Current	5 Amps	5 Amps
<b>Water</b>		
Inlet connections	15 mm push-fit connectors	15 mm push-fit connectors
Outlet connections	15 mm push-fit connectors	15 mm push-fit connectors
<b>Water pressures</b>		
Maximum static	100 kPa (1.0 bar) @ 10 m head	1000 kPa (10 bar) @ 100 m head
Maximum running	100 kPa (1.0 bar) @ 10 m head	500 kPa (5.0 bar) @ 50 m head
Minimum running	1 kPa (0.01 bar) @ 0.1 m head	100 kPa (1.0 bar) @ 10 m head
<b>Water temperature requirements</b>		
Maximum hot water	65°C	65°C
Minimum hot water	52°C	52°C
Maximum cold water	20°C	20°C
<b>Temperature adjustment range</b>	35 to 47°C (Max. temperature can be adjusted to 41°C setting)	35 to 47°C
<b>Material</b>		
Backplate, cover	ABS	ABS
<b>Dimensions (in millimetres)</b>		
Height	210	210
Width	355	355
Depth	100	100
<b>Splashproof rating</b>	IPX4	IPX4

## GENERAL INSTALLATION NOTES

The following notes are given as the suggested steps for installing the Satellites mixer shower and remote control:

### 1. Site survey

Determine the position of all parts of the shower (kit, mixing unit and control) before starting the installation.

### 2. Fit the mixing unit

### 3. Install the appropriate riser rail

Having determined the position of the mixing unit, decide on which riser rail kit to use. Option 1 is for rear supply; Options 2 and Option 3 are for a falling supply.

**Note:** If not installing the Metis riser rail kit, please refer to the alternative kit installation instructions before routing any pipework or electrical cables.

### 4. Install the pipework and plumbing

Run the pipework from the mixing unit to the chosen outlet. The rear supply will terminate at the bulkhead position, while a falling supply will terminate in the loft at the top of the riser rail. Connect the inlet pipework, the outlet pipework and then the outlet fittings.

### 5. Electrical connections

Connect the mixing unit to the electrical supplies.

### 6. Register the remote control panel

Register the control panel to the mixing unit.

### 7. Commission the unit

Commission the shower and select the desired feature settings.

### 8. Fit the control panel to the wall.

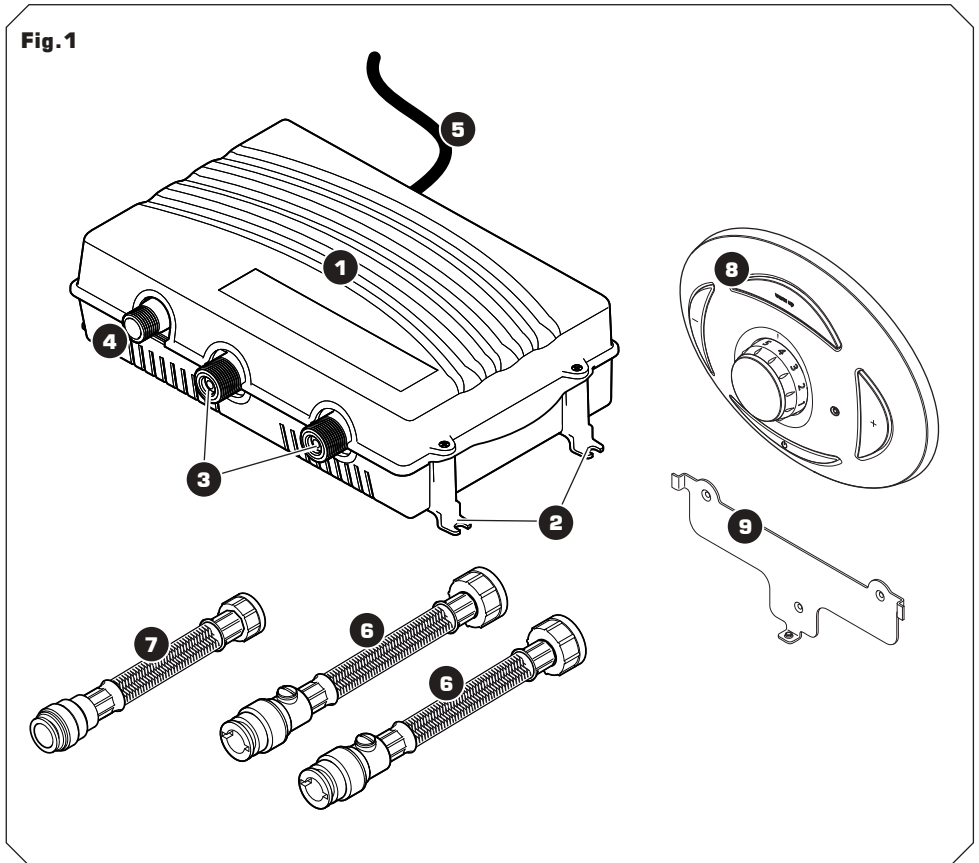
Install the remote control panel wall mounting bracket within the showering area. Fit the control panel onto the bracket.

### 9. Operation

Operate the shower and set preferred flow settings.

## MAIN COMPONENTS

**Fig. 1**



### **Mixing unit & remote control unit (fig. 1)**

- |  |   |
|--|---|
| <ul style="list-style-type: none"> <li><b>1.</b> Cover</li> <li><b>2.</b> Screw fixing point</li> <li><b>3.</b> Water entry points<br/>(Blue = Cold, Red = Hot)</li> <li><b>4.</b> Outlet</li> <li><b>5.</b> Mains electrical wire</li> <li><b>6.</b> 15 mm push-fit inlet connectors</li> </ul> | <ul style="list-style-type: none"> <li><b>7.</b> 15 mm push-fit outlet connector</li> <li><b>8.</b> Sirona remote control unit</li> <li><b>9.</b> Mounting bracket</li> </ul> |
|--|---|

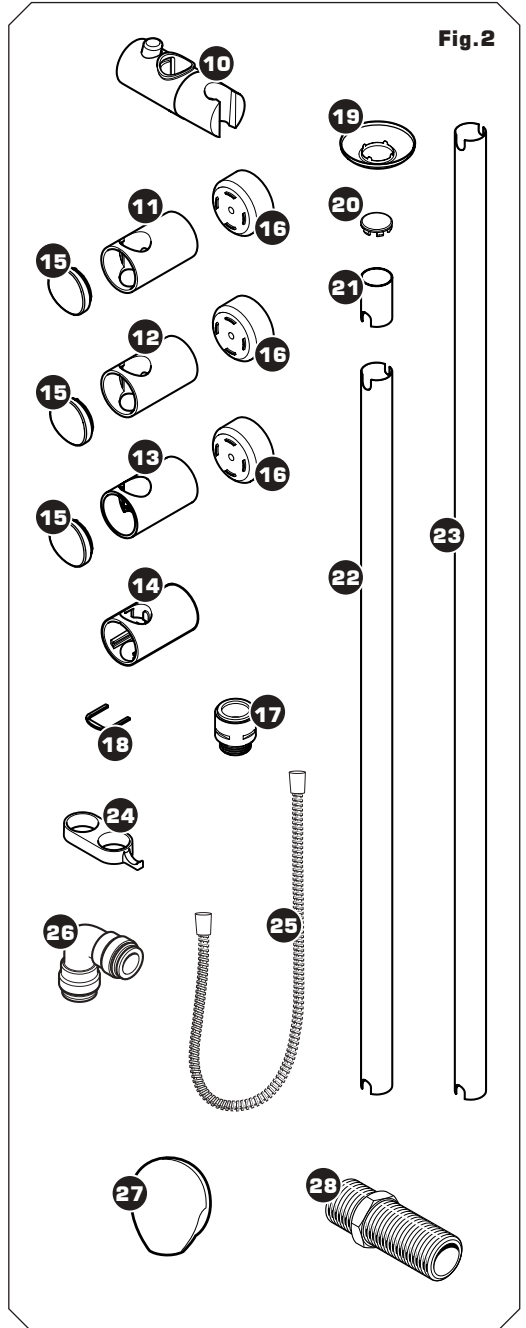
All dimensions listed in this fitting book regarding the product and installation are approximate.

\*All kits are for illustration purposes only and are not supplied unless otherwise stated.

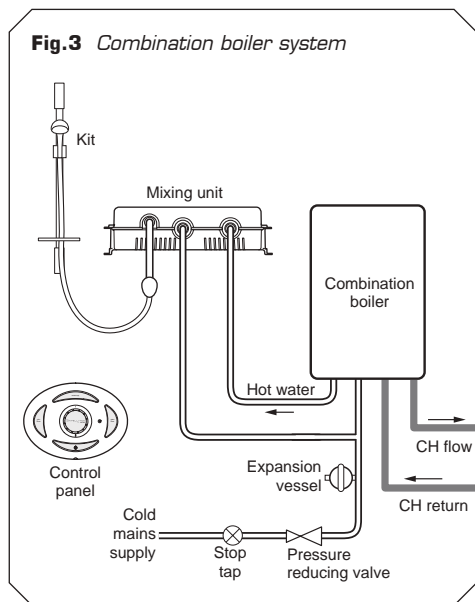


**Riser rail kit (fig.2)**

- 10.** Showerhead holder
- 11.** Bridging wall bracket (*lug on inside*)
- 12.** Guide bracket (*no lugs inside*)
- 13.** Bottom bracket
- 14.** Bottom bracket (*through ceiling option*)
- 15.** Bracket trim ring (3 off)
- 16.** Bracket spacer (3 off)
- 17.** Heated water pipe hose connector
- 18.** Water outlet fitting retaining clip
- 19.** Ceiling trim
- 20.** Riser rail end trim
- 21.** Riser rail – 40 mm
- 22.** Riser rail – 700 mm
- 23.** Riser rail – 940 mm
- 24.** Hose retainer
- 25.** Flexible hose
- 26.** 15 mm push-fit elbow
- 27.** Outlet bulkhead
- 28.** All thread fitting



## TYPICAL SUITABLE INSTALLATIONS



### a) High pressure system - Instantaneous gas-heated systems, e.g. combination boilers (Fig.3)

The high pressure mixing unit **MUST** be installed with a multipoint gas water heater or combination boiler of a fully modulating design (i.e. to maintain relatively stable hot water temperatures).

A drop tight pressure reducing valve **MUST** be fitted if the supply pressures exceed 500 kPa (5 bar) running.

An expansion vessel (shown in **Fig.3**) **MUST** be fitted, and regularly maintained, to prevent the shower being damaged by excess pressures. This may already be installed within the boiler (check with manufacturer) and is in addition to the normally larger central heating expansion vessel.

The layout and sizing of pipework **MUST** be such that nominally equal inlet supply pressures are achieved and the effects of other draw-offs are minimised.

If using the 'WARM UP' feature of the control unit with a instantaneous water heater appliance the user may experience a brief temperature variation upon restart. This is due to the way in which a combi-boiler operates, such that the boiler will turn off after the warm up process has been completed. When restarted, the mixing unit will release a cold slug of water followed by a hot slug as the hot water supply stabilises.

**IMPORTANT:** If the combi-boiler is a step-modulating type (i.e. it does **NOT** provide a stable output temperature under changing flow rates) then the 'Flow regulation' setting (Dip Switch 4) **MUST** be left set to 'ON'. See 'Commissioning'.

### Instantaneous water heater appliance capabilities

In order to provide the best performance from the high pressure mixing unit when

connected to an instantaneous water heater, the appliance must be capable of raising the temperature of the incoming water to a minimum of 52°C (125°F) and delivering a flow rate of not less than eight litres per minute.

**b) High pressure system - Unvented mains pressure systems (Fig.4)**

The high pressure mixing unit MUST be installed with an unvented, stored hot water cylinder.

For systems with no cold water take off after the appliance reducing valve, it will be necessary to fit an additional drop tight pressure reducing valve when the mains pressure is over 500 kPa (5 bar). The drop tight pressure reducing valve must be set at the same value as the unvented package pressure reducing valve.

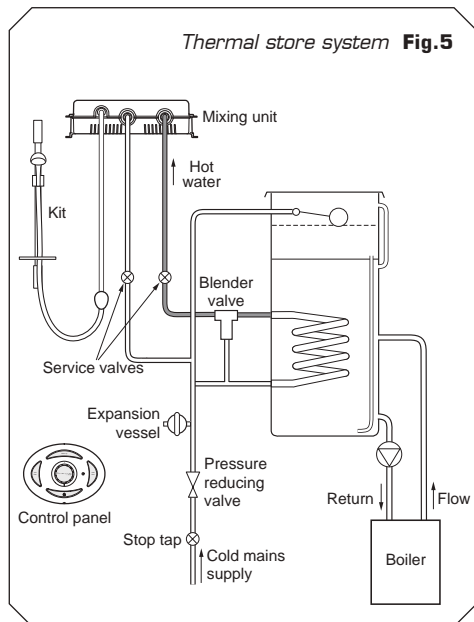
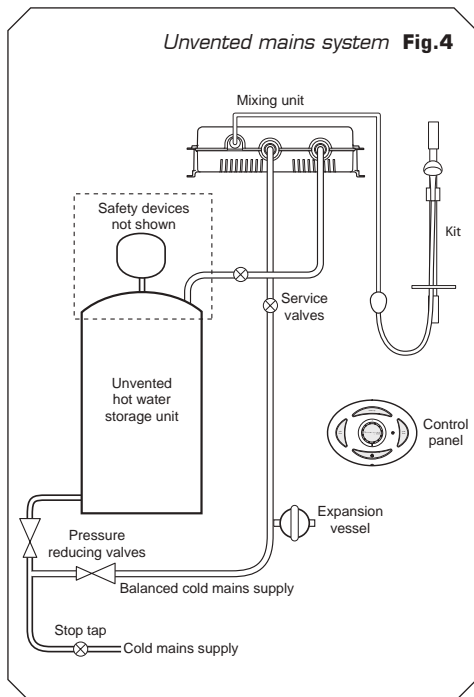
**Note:** An additional expansion vessel (Fig.4) may be required if a second pressure reducing valve is installed. This does not apply to packages with a cold take off after the pressure reducing valve to the cylinder.

The layout and sizing of pipework MUST be such that nominally equal inlet supply pressures are achieved and the effects of other draw-offs are minimised.

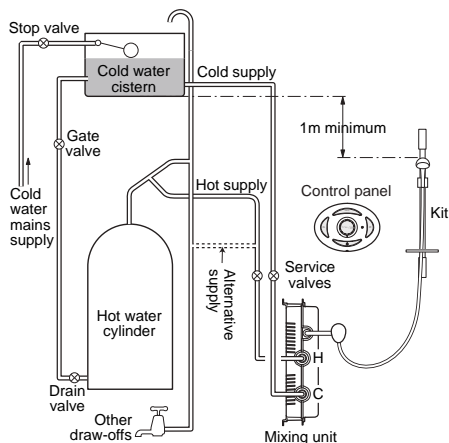
**c) High pressure system - Mains pressurised thermal store systems (Fig.5)**

The high pressure mixing unit, fitted with a tempering valve (blender valve), can be used. A drop tight pressure reducing valve must be fitted if the supply pressures exceed 500 kPa (5 bar) running.

An expansion vessel (shown in Fig.5) must be fitted, and regularly maintained, to ensure the unit is not damaged by excess pressures. This may already be installed externally or internally within the thermal store (check with thermal store manufacturer).



**Fig.6 Gravity fed system**



**IMPORTANT!!**

For the **LOW PRESSURE GRAVITY SYSTEM** - Fig.6 - the water inlets are:

**COLD** = Right hand side.

**HOT** = Middle.

**d) Low pressure system - Gravity fed systems (Fig.6)**

The low pressure mixing unit **MUST** be fed from a cold water cistern and hot water cylinder providing nominally equal pressures.

For the operation of the shower only, it is recommended that the cold water storage cistern is capable of holding at least 114 litres (25 gallons). Where other hot and cold outlets are likely to be in use simultaneously, the storage capacity should be increased to 228 litres (50 gallons) in accordance with BS 6700.

**IMPORTANT:** If the hot water draw-off is incorrectly positioned, air may be drawn into the hot supply from the vent pipe causing spluttering, temperature fluctuations at the showerhead.

Any draw-off for the mixer unit must point **DOWN** (to avoid air-lock problems) and must be **BELOW** the vent pipe tee.

Failure to correctly position the draw-off will result in poor performance or other problems with the mixing unit.

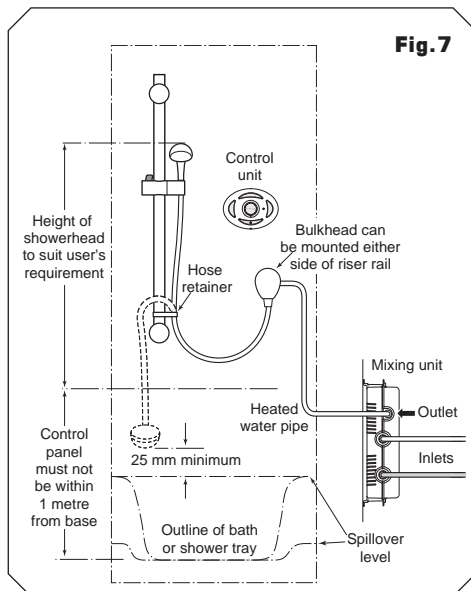
**IMPORTANT:** The minimum head for operation of the mixer unit is 100 mm. For correct operation the mixing unit must not be sited more than 5 metres away from the hot water cylinder.

## SITING OPTIONS

Refer to **Fig.7** and **Fig.8** for correct siting of the shower.

Position the control panel within 10 metres of the mixing unit, where it will NOT be in direct contact with water from the showerhead or any other Triton approved device. Position the mixing unit such that it is accessible for maintenance purposes.

**Note:** Water Regulations requires that the showerhead be *'constrained by a fixed or sliding attachment so that it can only discharge water at a point not less than 25 mm above the spill-over level of the relevant bath, shower tray or other fixed appliance'*. The use of a hose retainer will usually meet this requirement, but if the showerhead can be placed within a bath, basin or shower tray, then a single check valve, or a similar device must be fitted in the outlet pipework to prevent back-flow.



## Rear entry supply

The mixing unit is mounted behind an adjoining wall with a heated water pipe running to a bulkhead (**Fig.7**). Uses a stand-alone riser rail assembly.

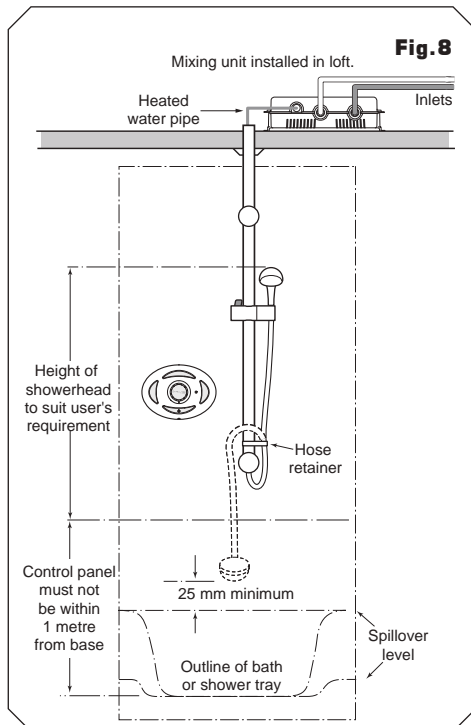
## Falling supply

Here the mixing unit is installed in the loft or behind an adjacent wall with the heated water pipe running down the inside of the riser rail. The water outlet is at the bottom of the riser rail (**Fig.8**).

**Note:** If the mixing unit is installed in the loft it is advisable to install above a catchment tank fitted with an overflow warning pipe. This will ensure that in the unlikely event of leakage from the mixing unit it will not go unnoticed.

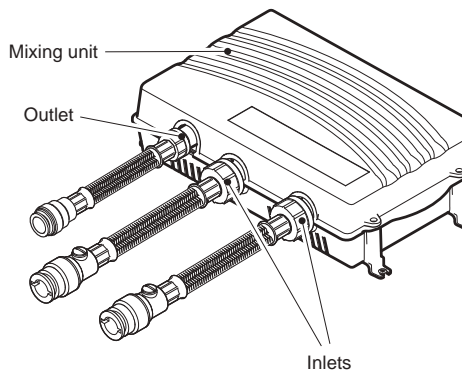
**IMPORTANT:** Leave enough space around the mixing unit to allow for the incoming and outgoing pipework fittings and connections.

Having selected one of the fitting options position the control panel and showerhead on the wall so that all controls can be reached comfortably when using the shower.

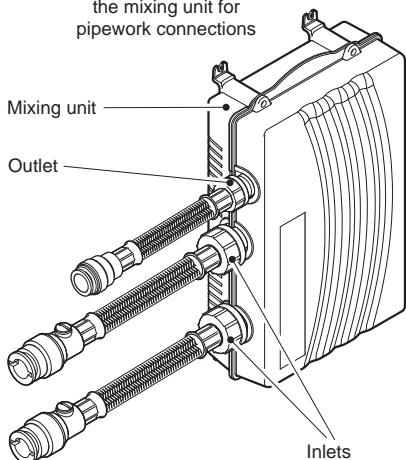


**Fig.9** Horizontal layout

Leave enough space around the mixing unit for pipework connections

**Fig.10** Vertical layout

Leave enough space around the mixing unit for pipework connections



## POSITIONING THE MIXING UNIT

The mixing unit **MUST** only be positioned as shown.

It can be mounted on a horizontal surface in any orientation (**Fig.9**).

When mounting on a vertical surface the mixing unit outlet **MUST** be at the top (**Fig.10**). Failure to position the unit correctly will result in a significant reduction in performance.

**Note:** If the mixer is to be mounted in a loft or airing cupboard where the ceiling or wall has metallic backing on the plasterboard then it may be necessary to remove a small section of the metallic backing to enable communication between the control panel and the mixing unit.

Removing an area of about 50 cm x 50 cm of the metallic backing from the ceiling or wall immediately above or behind where the control panel is mounted should be sufficient to enable correct communications.

**Note:** It is advisable to position the control panel and bracket on the wall to confirm correct communications before starting any drilling and fixing of the unit.

### PROFESSIONAL INSTALLER NOTES

In commercial premises metallic surfaces e.g. metal ceiling panels, metal ducting and metallic insulating materials may block wireless transmissions from the remote control panel and prevent correct operation of the shower.

Please contact Triton's Specification Advisory Service on 0844 980 0730 for guidance on commercial installations and if necessary make arrangements for a site survey.

**Note:** If mounting the mixing unit in a loft it is worth considering building a catchment tank with an overflow pipe directed to an external point. In the unlikely event of a problem occurring with the mixing unit this will give a visual indication of any failure.

## FITTING THE MIXER UNIT

Decide on the position for the mixing unit – see **Fig. 11** and **Fig. 12**. Position the mixing unit in a dry, well ventilated area.

Mark the four locating points for the base. If fixing to brick or a stud partition.

Drill and plug the wall.

*(An appropriate drill bit should be used. If the wall is brick, plasterboard or a soft building block, appropriate wall plugs and screws should be fitted).*

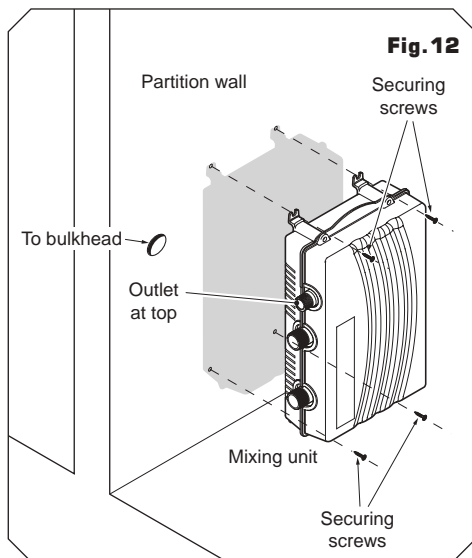
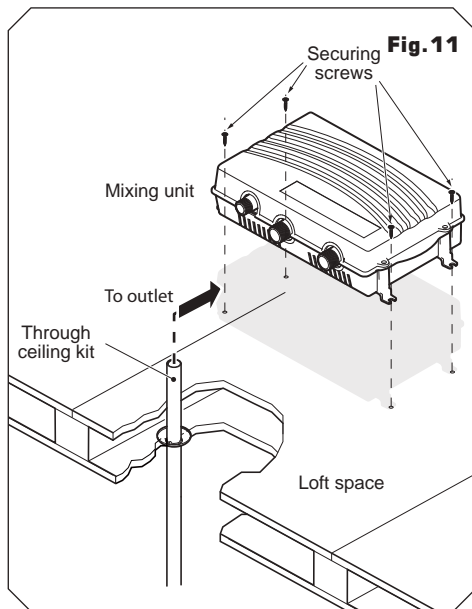
Secure the mixing unit in position. The mixing unit **MUST** always be positioned either flat on a suitable surface or on a wall so that there is easy access for installation and maintenance.

**IMPORTANT:** If wall mounting the mixing unit the outlet **MUST** always be at the top (**Fig. 11**).

**IMPORTANT:** Before drilling holes in the ceiling or wall surface make sure there is enough clearance above the ceiling to accommodate the entry of the riser rail and heated water pipe.

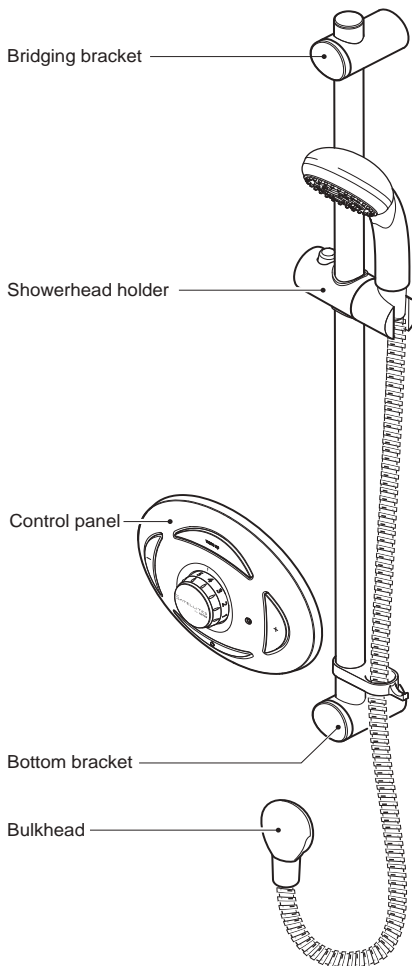
If the mixing unit is installed in a loft area the following requirements must be met for future servicing purposes:

- a. There must be no risk of the mixing unit or heated water pipe becoming frozen.
- b. The mixing unit **MUST NOT** be covered with any form of insulating material that may give rise to electrical circuits overheating during periods of high ambient temperature.
- c. A safe means of access must be provided into the loft, e.g. via a fixed loft ladder.
- d. The mixing unit **MUST** be installed in an accessible and safe location.
- e. Ceiling joists **MUST** be adequately boarded to provide safe and unobstructed access to, from and around the mixing unit.
- f. There **MUST** be adequate lighting in the loft for servicing purposes.



## \*RISER RAIL INSTALLATION OPTIONS

**Fig.13** *Option 1: Rear entry supply*



### Option 1: Rear entry supply

The control panel is installed onto a tiled wall. The mixing unit is behind an adjoining wall with heated water pipe (supplied in the mixing unit) running to the bulkhead (**Fig.13**).

### Options 2 & 3: Falling supply

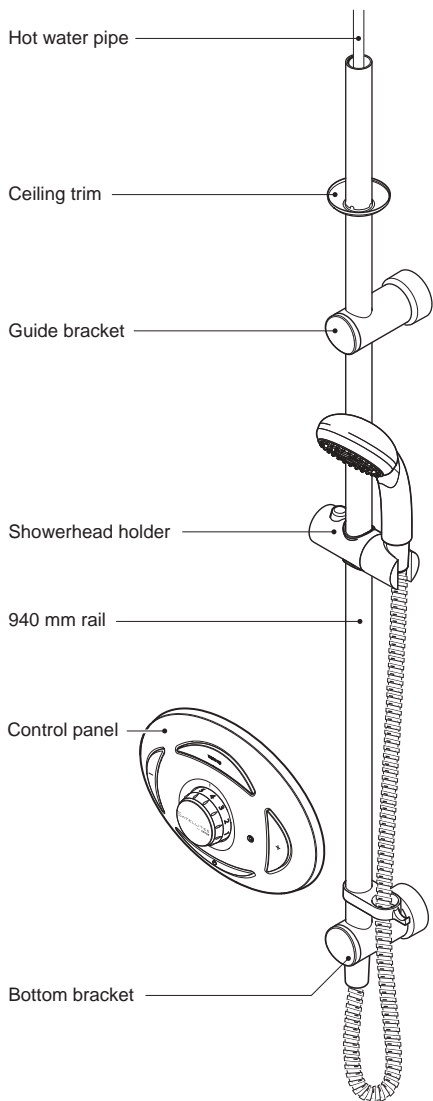
Here the mixing unit is installed in the loft with the heated water pipe (supplied in the mixing unit) running down the inside of the riser rail. Water outlet at the bottom of the riser rail.

**Fig.14** shows the shorter version using the 940 mm riser rail passing through the guide bracket.

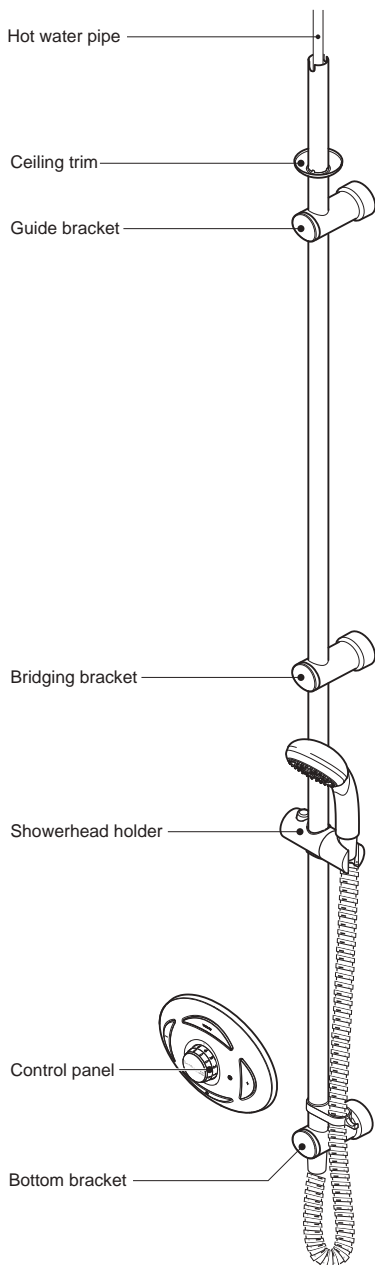
**Fig.15** shows the long version using three brackets and both riser rail sections. This uses the 700 mm rail connecting to the bridging bracket with the 940 mm rail cut to length.



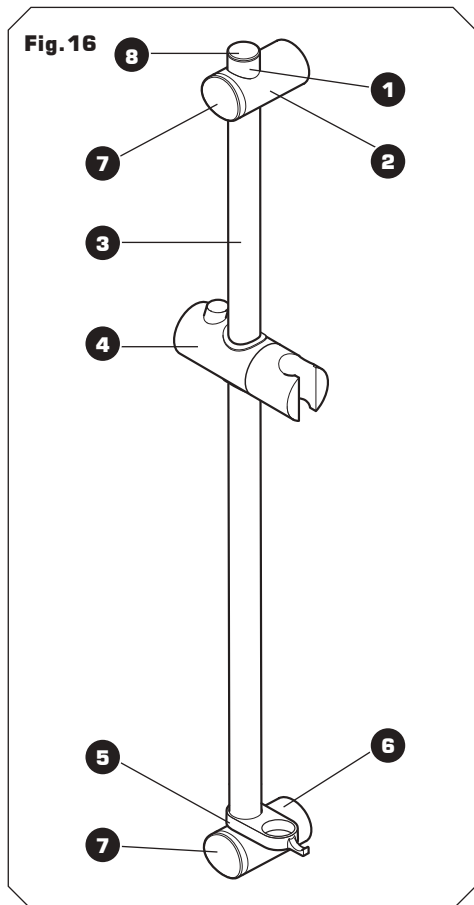
**Fig. 14** Option 2: Falling supply fitting (short)



Option 3: Falling supply fitting (long) **Fig. 15**



## \*INSTALLATION OPTION 1: REAR ENTRY SUPPLY



### COMPONENTS

This option is for installing the riser rail for use with a rear entry supply (bulkhead fitting).

**Fig. 16** shows the parts required to install the stand-alone riser rail kit. Note that either riser rail section can be used.

1. 40 mm riser rail section
2. Bridging bracket
3. 700 mm or 940 mm riser rail section
4. Showerhead holder
5. Hose retainer
6. Bottom bracket (blanked off)
7. Bracket end trim (2 off)
8. Riser rail end trim
  - Bulkhead assembly

### FITTING THE RISER RAIL

#### WARNING!

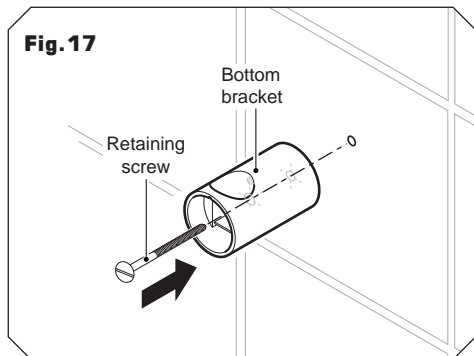
**The edges of the riser rail are extremely sharp. Take care when handling and cutting the rails.**

Decide the position for the rail on the wall within the shower area. Proceed as follows:  
Offer the bottom bracket to the wall and mark the centre hole.

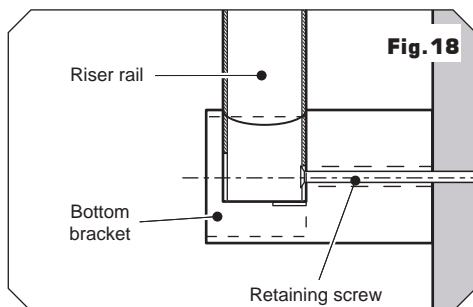
Drill and plug the wall.

*(An appropriate drill bit should be used. If the wall is brick, plasterboard or a soft building block, appropriate wall plugs and screws should be fitted).*

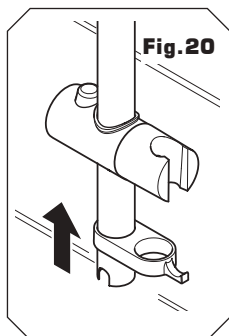
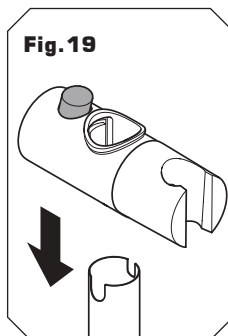
Secure the bottom bracket to the wall (**Fig. 17**). **DO NOT** tighten at this stage.



Insert the riser rail section into the bottom bracket (**Fig. 18**) so that the smaller of the rail cut-outs locates onto the retaining screw. Fit the bridging bracket onto the top of the rail, making sure that the cut-out in the riser rail engages fully with the lug inside the bracket. Align the rail vertically and mark the centre hole for the bridging bracket. Remove the bracket and rail then drill and plug the wall.



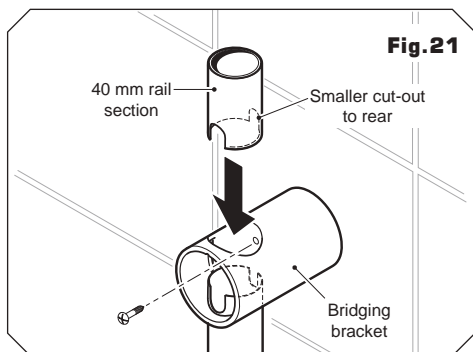
Fit the showerhead holder onto the riser rail section – press and hold the button on top of the holder to release the locking mechanism, then slide onto the rail (**Fig. 19**). Release the button to lock the holder in place.



Fit the hose retainer underneath the holder (**Fig. 20**). Place the riser rail section, showerhead holder and hose retainer onto the installed bottom bracket. Make sure the smaller cut-out locates once more onto the retaining screw before tightening in place.

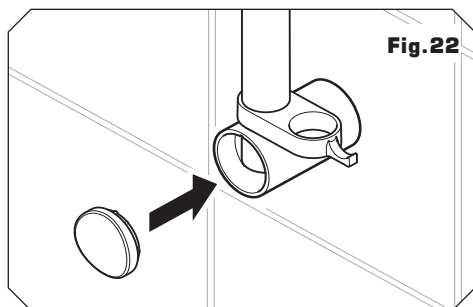
Replace the bridging bracket onto the rail, locate onto the riser rail lug, and secure to the wall.

Insert the 40 mm riser rail section into the top of the bridging bracket. Make sure the smaller cut-out in the rail is facing towards the rear and secure to the bracket with a small screw (**Fig. 21**).



**Note:** The screw will pass through the cut-out in the front of the riser rail and secure the rear of the riser rail to the bracket.

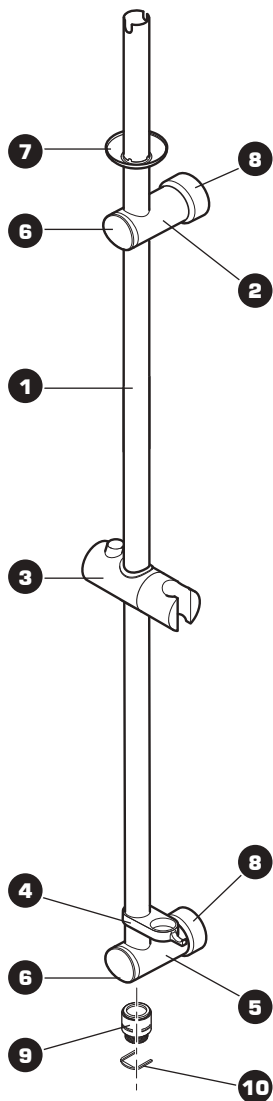
Push fit a bracket end trim onto each bracket (**Fig. 22**) and insert the riser rail trim into the top of the riser rail assembly.



Refer to 'Outgoing plumbing connections' for details on fitting the bulkhead.

**\*INSTALLATION OPTION 2: FALLING SUPPLIES - THROUGH THE CEILING RISER RAIL (SHORT)**

**Fig.23**



**COMPONENTS**

**Fig.23** shows the parts required to install the short version of the through the ceiling riser rail kit.

1. 940 mm riser rail section
2. Guide bracket
3. Showerhead holder
4. Hose retainer
5. Bottom bracket
6. Bracket end trim (2 off)
7. Ceiling trim
8. Spacer – optional (2 off)
9. Outlet connector
10. Securing clip

## \*FITTING THE THROUGH CEILING RISER RAIL

When determining your required riser rail length allow a minimum distance of 50 mm between the ceiling and the uppermost bracket. Make sure there is sufficient length of riser rail above the ceiling level to overcome any obstructions to running the heated water pipe, such as the height of the ceiling joist (**Fig.24**).

**Note:** The spacers supplied provide an additional 25 mm of depth for the riser rail installation to avoid hitting a loft ceiling joist (**Fig.24**).

### Procedure

Assemble the bottom and guide brackets onto the 940 mm section of rail. Make sure the rail engages fully into the brackets.

Hold the riser rail assembly up to the wall and align vertically to determine the height of the showerhead and control panel when installed. Mark the position for the guide bracket. Remove the assembly then drill and plug the wall.

Secure the guide bracket (and spacer) to the wall.

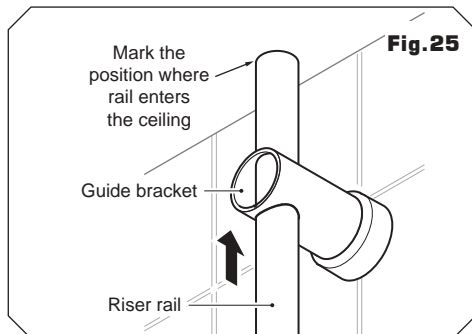
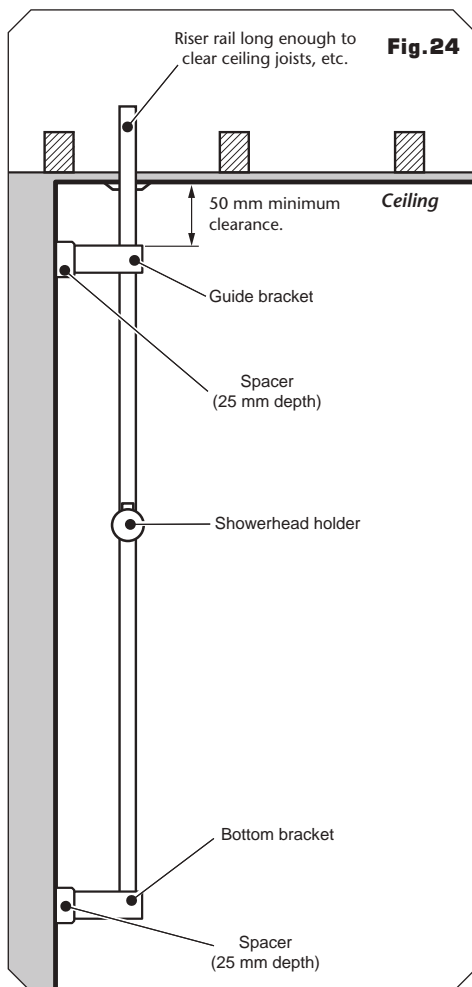
Slide the riser rail up through the guide bracket until it touches the ceiling (**Fig.25**). Using a spirit level, align the riser rail vertically and mark the centre hole position of the rail on the ceiling. Remove the rail.

Using a 26 mm hole cutter, drill the ceiling opening.

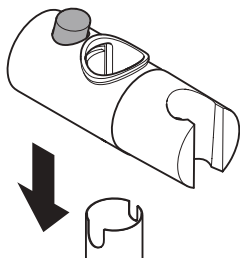
Fit the riser rail into the bottom bracket and secure with the small screw.

**IMPORTANT:** Before securing the rail to the bracket, test fit the outlet connector and clip to make sure they will fit into the bottom bracket with the rail in place.

Feed the riser rail assembly through the base of the guide bracket and into the ceiling opening. Using a spirit level, align the riser rail vertically and mark the bottom bracket centre hole position.



**Fig.26**

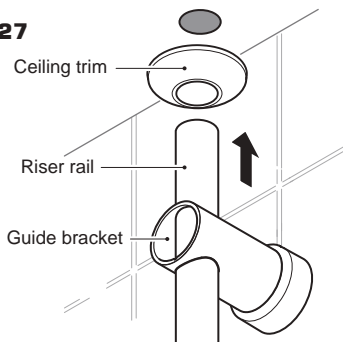


**IMPORTANT:** Remember to add the extra length of rail to the measurements to clear any obstructions above the ceiling level (**Fig.24**) before marking.

Remove the assembly then drill and plug the wall.

Slide the hose retainer onto the lower rail section. Fit the showerhead holder onto the riser rail section – press and hold the button on top of the holder to release the locking mechanism, then slide onto the rail (**Fig.26**). Release the button to lock the holder in place.

**Fig.27**



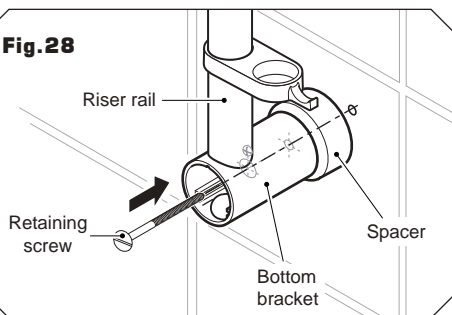
Fit the riser rail through the guide bracket before sliding the ceiling trim over the rail end, and feeding the rail into the ceiling opening (**Fig.27**).

Secure the rail and bottom bracket assembly to the wall using the screw supplied (**Fig.28**).

Slide the ceiling trim up to the ceiling.

Refer to 'Outgoing plumbing connections' for details on fitting the heated water pipe.

**Fig.28**

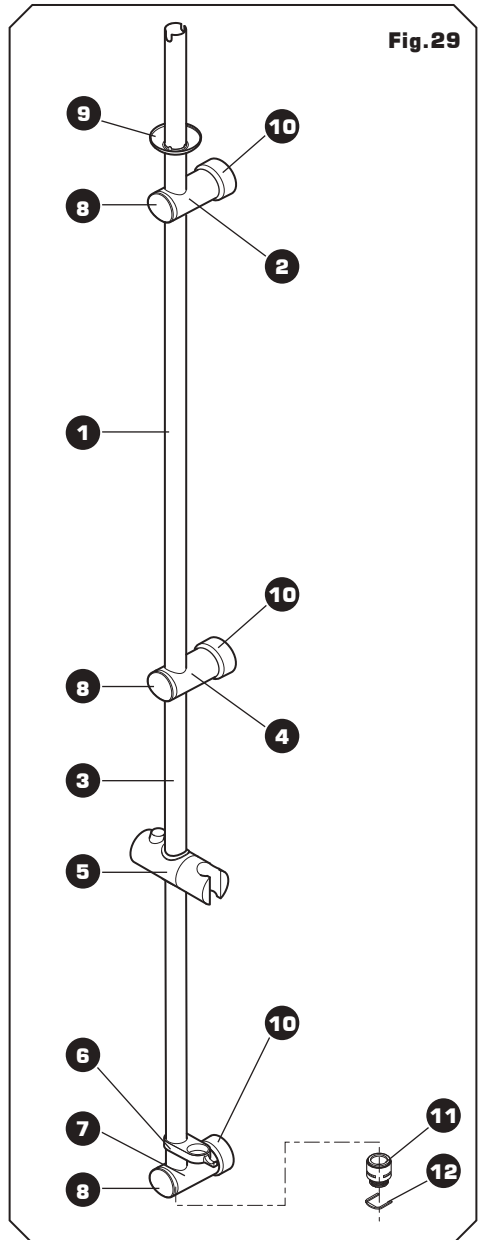


## \*INSTALLATION OPTION 3: FALLING SUPPLES - THROUGH THE CEILING RISER RAIL (LONG)

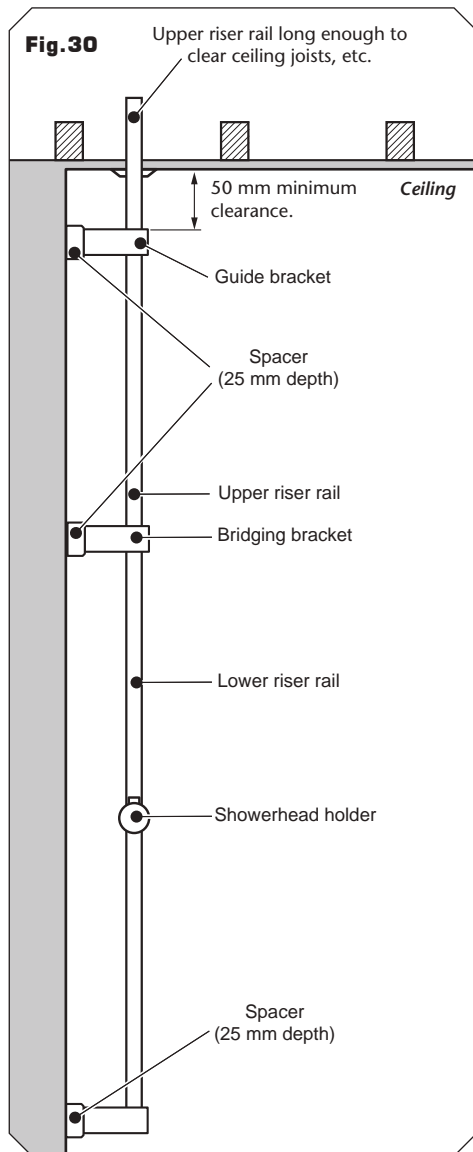
### COMPONENTS

**Fig.29** shows the parts required to install the through the ceiling riser rail kit. Note that parts (1) and (3) can be interchanged depending on the user's requirements.

1. 940 mm riser rail section
2. Guide bracket
3. 700 mm riser rail section
4. Bridging bracket
5. Showerhead holder
6. Hose retainer
7. Bottom bracket
8. Bracket end trim (3 off)
9. Ceiling trim
10. Spacer – optional (3 off)
11. Outlet connector
12. Securing clip



**Fig.29**



**Fig. 30**

## \*FITTING THE THROUGH CEILING RISER RAIL

**Note:** There are two lengths of riser rail supplied to cater for differing layouts and ceiling heights. It may be necessary to shorten one of the riser rail sections using a suitable hacksaw or pipe cutter.

When determining your required riser rail length allow a minimum distance of 50 mm between the ceiling and the uppermost bracket. Make sure there is sufficient length of riser rail above the ceiling level to overcome any obstructions to running the heated water pipe, such as the height of the ceiling joist (**Fig.30**).

**Note:** The spacers supplied provide an additional 25 mm of depth for the riser rail installation to avoid hitting a loft ceiling joist (**Fig.30**).

### Procedure

**IMPORTANT:** The procedure given here uses the 700 mm rail section for the lower section and the 940 mm rail section to enter into the ceiling.

Assemble the bottom and bridging brackets onto the 700 mm section of rail. Make sure the rail engages fully into the brackets.

Hold the riser rail assembly up to the wall and align vertically to determine the height of the showerhead and control panel when installed.

Mark the centre hole position for the bridging bracket and remove the assembly. Drill and plug the wall.

Secure temporarily the guide bracket (and spacer, if used) to the bridging bracket point.

Fit the bottom bracket to the riser rail and slide the rail section up through the guide bracket until it touches the ceiling (**Fig.31**). Align the rail vertically. Mark the centre hole position of the rail on the ceiling. Remove the rail section and the guide bracket and, using a 26 mm hole cutter, drill the ceiling opening.

### **WARNING!**

**The edges of the riser rail are extremely sharp. Take care when handling and cutting the rails.**



Fit the bridging bracket (*and spacer*) to the wall using the screw supplied, making sure the small lug inside the bracket faces down.

Measure the 940 mm rail (*for the upper section of rail*) and mark the required length to fit between the bridging bracket and into the ceiling. Remember to add the extra length of rail onto the measurements to clear any obstructions above the ceiling level (**Fig.30**). Cut the riser rail to length and deburr.

If the upper rail section is sufficiently long, fix the guide bracket (*and spacer*) onto the wall for additional support (**Fig.30**).

Feed the cut upper riser rail through the guide bracket (*if used*) before sliding the ceiling trim down onto the rail. Slide the riser rail into the ceiling opening and drop back into the bridging bracket, with the smaller of the cut-outs facing towards the rear. Secure the rail to the bridging bracket using the small screw supplied (**Fig.32**).

Slide the ceiling trim up to the ceiling.

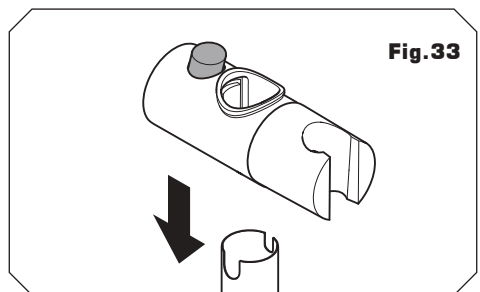
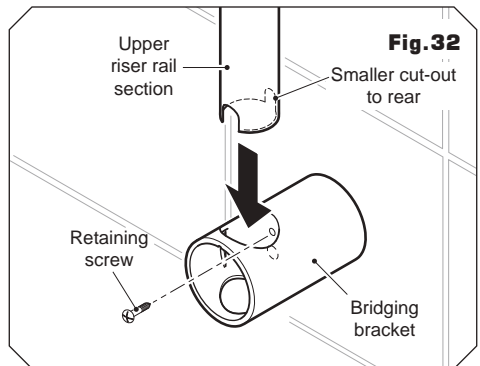
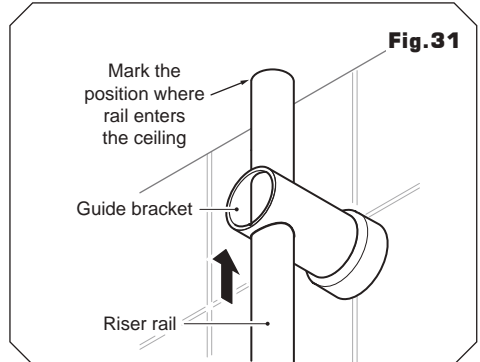
Fit the 700 mm riser rail into the bottom bracket with the smaller cut-outs facing towards the rear and secure with the small screw supplied.

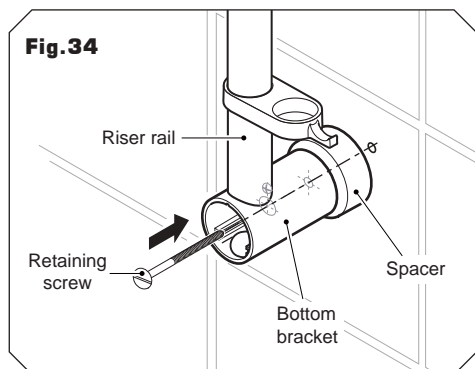
**IMPORTANT:** Before securing the rail, test fit the outlet connector and clip to make sure it will fit into the bottom bracket with the rail in place.

Fit the lower riser rail assembly into the base of the bridging bracket, making sure the small cut-out engages the bracket lug. Using a spirit level, align the riser rail vertically and mark the bottom bracket centre hole position. Remove the assembly. Drill and plug the wall.

Slide the hose retainer onto the lower rail section.

Fit the showerhead holder onto the riser rail section – press and hold the button on top of the holder to release the locking mechanism, then slide onto the rail (**Fig.33**). Release the button to lock the holder in place.





Refit the lower riser rail assembly into the base of the bridging bracket, again making sure the small cut-out engages the bracket lug. Secure the rail and bottom bracket assembly to the wall using the screw supplied (**Fig.34**).

Refer to *'Outgoing plumbing connections'* for details on fitting the heated water pipe.

### WARNING!

**This appliance is not intended for use by persons (including children) with reduced physical, sensory or mental capabilities, or lack of experience and knowledge, unless they have been given supervision or instruction concerning use of the appliance by a person responsible for their safety.**

**Children should be supervised to ensure that they do not play with the appliance.**

## INCOMING PLUMBING CONNECTIONS *(Plumbing to be carried out before wiring)*

- DO NOT use jointing compounds on any pipe fittings for the installation.
- DO NOT solder fittings near the shower unit as heat can transfer along pipework and damage components.
- DO NOT bend or kink the braided push-fit connectors.

### Procedure

Turn off the water supplies either at the mains stopvalve or the isolating stopvalve.

Having decided on the position of the unit and direction of pipe entry, complete the pipework to the mixing unit.

Insert the incoming pipework into the 15 mm braided push-fit connectors (**Fig.35**).

**IMPORTANT:** The fittings on the inlet elbows are the push-in type. The pipework must be cut with a pipe cutter and all burrs and rough edges removed from the end of the tube. The fittings can be used with copper and plastic pipe.

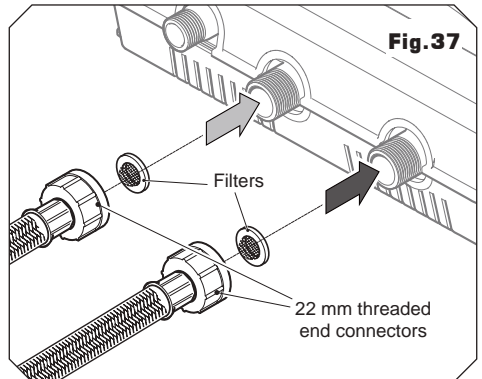
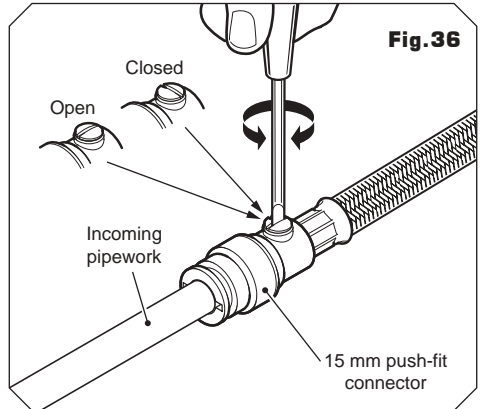
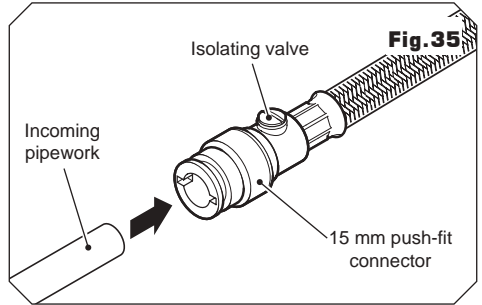
If using chrome plated copper pipe, remove the first 25mm of plating completely from the connecting surfaces. If not completely removed then the collet will not grip the pipe and under pressure the pipe may be forced out.

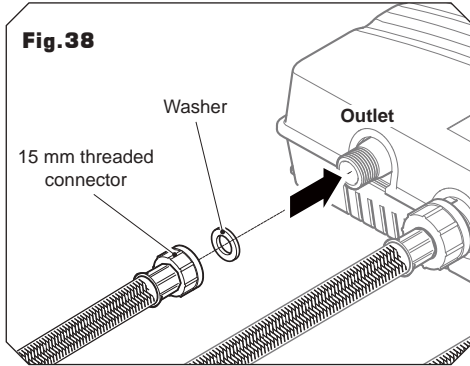
**IMPORTANT:** Before completing the connection of the water supplies to the inlets of the mixing unit, flush out the pipework to remove all swarf, system debris and air from the system.

Check that the isolating valves on the inlet connectors are fully open (**Fig.36**). Turn on the water supplies to clear the debris to waste and to purge air from the supplies.

Check for leaks before connecting the pipework to the mixer.

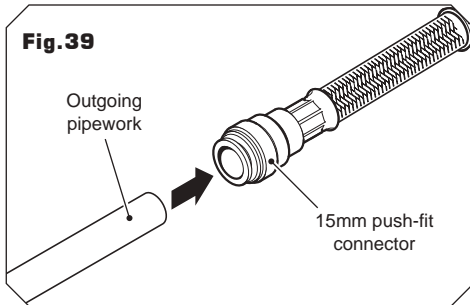
Screw the two push-fit connectors (**Fig.37**) to the mixing unit inlets – cold to BLUE, hot to RED – as indicated on the mixing unit label. Make sure the filters are in place before fitting.





DO NOT use excessive force when making these connections.

**Note:** The inlet connectors contain filters. These should be periodically removed and cleaned in order to maintain the performance of the shower. See section '*Cleaning*' on how to access the filters.



## OUTGOING PLUMBING CONNECTIONS *(Plumbing to be carried out before wiring)*

Screw the 15mm threaded connector to the mixing unit outlet (**Fig.38**). Make sure the washer is in place before fitting.

Insert the outlet pipework into the 15mm braided push-fit connector (**Fig.39**).

### Option 1: Rear supply - Fitting the bulkhead

Connect the heated water pipe to a 1/2" BSP x 15 mm female thread elbow or straight coupler compression fitting (**Fig.40**).

**Note:** This fitting is not supplied as variations in installations requires selection of the most suitable fitting.

Screw the supplied male-thread connector into the female fitting (**Fig.41**) using PTFE tape to give a watertight joint.

**Note:** The male-thread connector supplied has a shoulder. If fitting into a flush wall, make an additional 8mm allowance for this shoulder at the finished surface. The connector can be cut to size if required.

The threaded connector should protrude from the wall surface between 8 mm and 13mm.

Make good the wall.

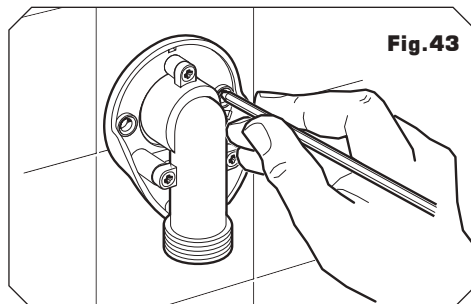
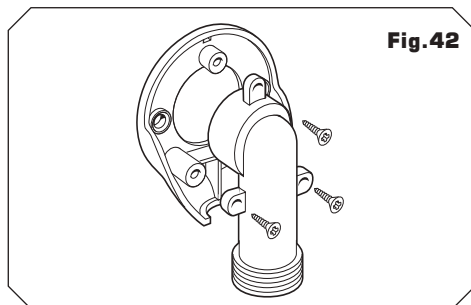
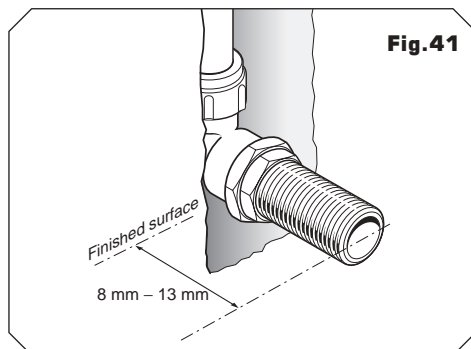
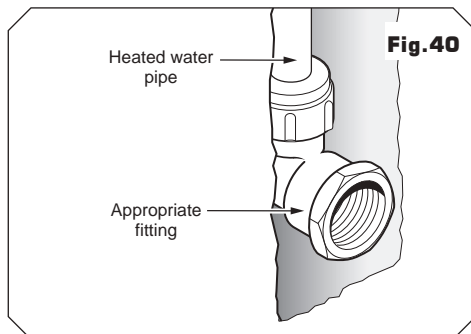
The bulkhead and its cover are supplied assembled. Separate the two halves by carefully prising apart at the smaller of the two elbow apertures.

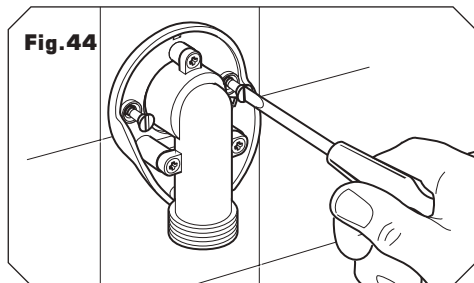
Secure the elbow to the bulkhead body with the three screws supplied (**Fig.42**).

Screw the bulkhead assembly onto the threaded connector temporarily. Mark the position of the two fixing holes (**Fig.43**) securing the bulkhead to the wall.

**Note:** If screw thread protrudes too far out of the wall, it can be cut to the correct length using a hacksaw.

Unscrew and remove the bulkhead assembly. Check the location of the pipe in the wall before drilling.





**Fig. 44**

Drill and plug the wall.

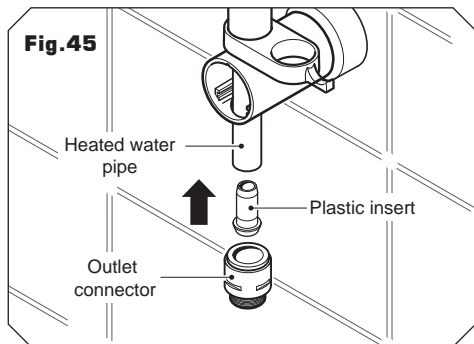
*(An appropriate drill bit should be used. If the wall is brick, plasterboard or a soft building block, appropriate wall plugs and screws should be fitted).*

If fitting to a hollow wall structure, it may be preferable to secure the bulkhead by applying a bead of silicon seal to the back of the bulkhead.

Apply PTFE tape to the threaded connector.

Screw the bulkhead assembly onto the threaded connector until tight to the wall and the two fixing holes are aligned. Secure to the wall with the two screws supplied (**Fig. 44**).

Finish by clipping the cover onto the bulkhead making sure the protruding legs locate in the bulkhead body.



**Fig. 45**

### Options 2 & 3: Falling supply - Connecting the heated water pipe

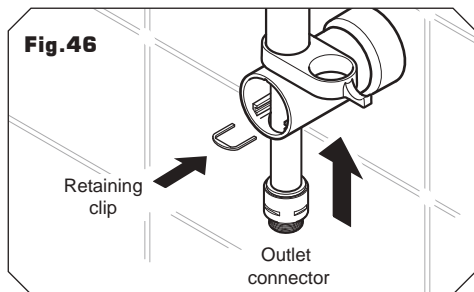
The 15mm heated water pipe feeds down through the centre of the riser rail. This runs from the centre of the push-fit elbow at the top of the riser rail and terminates to the outlet connector at the base of the through ceiling kit. The heated water pipe is connected to the outlet pipework via the 15mm push-fit elbow.

Fit one of the supplied plastic tube inserts into one end of the water pipe until it is flush. This will provide extra support to the plastic pipe. Push fit the outlet connector onto the heated water pipe (**Fig. 45**).

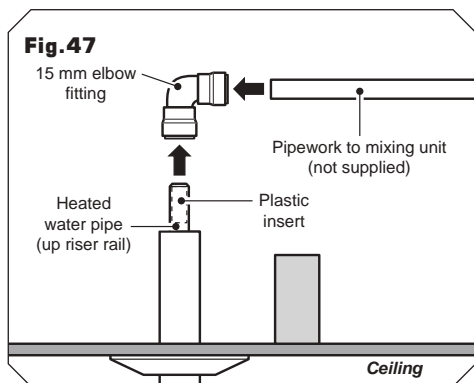
Feed the heated water pipe and connector back up the rail and secure the connector with the retaining clip (**Fig. 46**).

In the loft, trim the heated water pipe excess to length. Insert the remaining plastic tube insert into the end of the water pipe and then push fit into the 15mm elbow fitting (**Fig. 47**).

Fit the bracket end trims onto the brackets.



**Fig. 46**



**Fig. 47**

## \*FITTING THE HOSE AND SHOWERHEAD

Feed the flexible hose through the hose retainer opening (**Fig.48**) so that it acts as a retaining ring (Water Regulations).

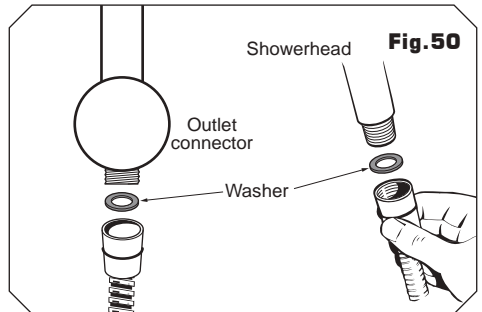
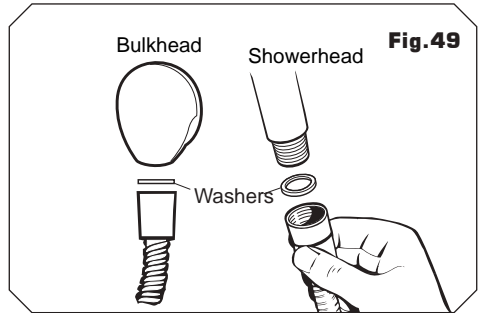
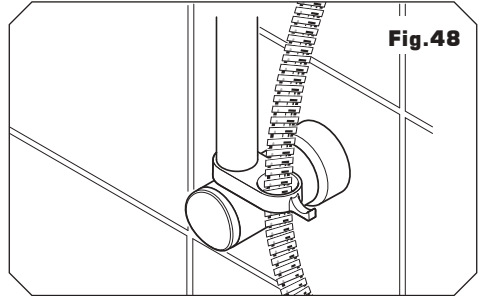
Screw the flexible hose to the bulkhead (**Fig.49**) or the outlet connector (**Fig.50**) and the other end to the showerhead. Make sure the supplied washers are in place at both ends of the flexible hose.

Place the showerhead into the holder and check that it fits correctly.

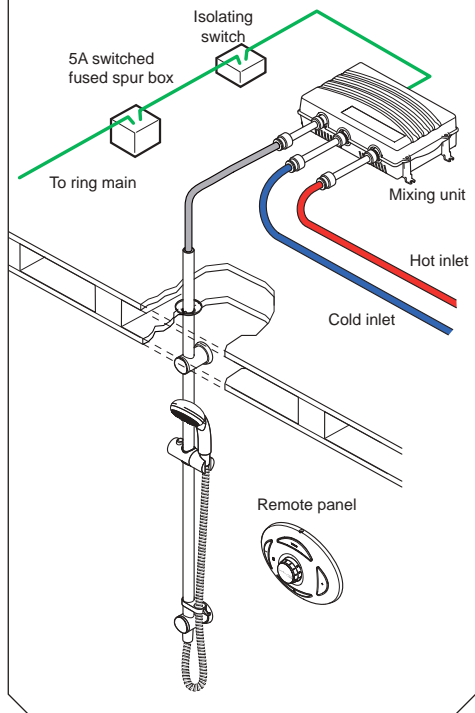
**Note:** The holder is slightly tapered and the showerhead and hose will only fit from one direction.

**IMPORTANT:** It is the conical end of the hose which grips into the holder. The showerhead will not fit in the holder without the hose attached.

At this stage, disconnect the showerhead and lay aside until the shower unit has been commissioned.



**Fig. 51**



## ELECTRICAL CONNECTIONS

### SWITCH OFF THE ELECTRICITY SUPPLY AT THE MAINS.

Connect the cable from the mixing unit to a 5 amp fused connection unit (**Fig.51**):

Earth cable marked **E**  $\oplus$  Green/yellow  
 Neutral cable marked **N** Blue  
 Live cable marked **L** Brown

**Note:** If the mixing unit is to be installed within the bathroom beneath a bath or in an enclosed cupboard then the earth continuity of the installation must be effectively connected electrically to all exposed metal parts in the room or cupboard to conform with IEE regulations.

The disconnection must be incorporated in the fixed wiring in accordance with the wiring rules.

If the supply cord is damaged, it must be replaced by the manufacturer, its service agent or similarly qualified persons in order to avoid a hazard.

**DO NOT** switch on the electricity supply until the water has been turned on to the unit and connections have been tested for leaks.



## REGISTERING THE SHOWER UNIT

### Fitting the batteries

Remove the two screws securing the battery cover (Fig.52). Insert two AAA alkaline batteries into the control panel.

**IMPORTANT:** Make sure to fit the batteries correctly otherwise the circuit board will be damaged.

### Registering

Before the shower can be used the control panel must be registered to the mixing unit. This will link the control panel to the specific mixing unit.

**Note:** This procedure MUST be carried out before fitting the battery cover and before fitting to the wall.

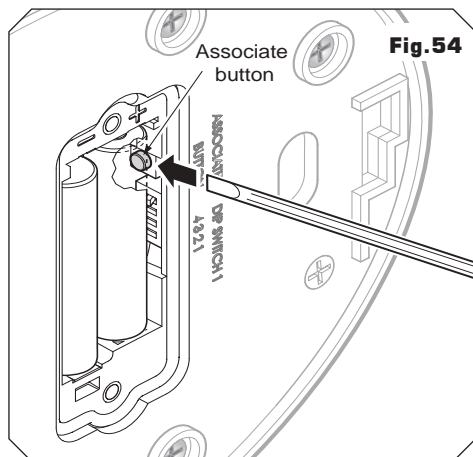
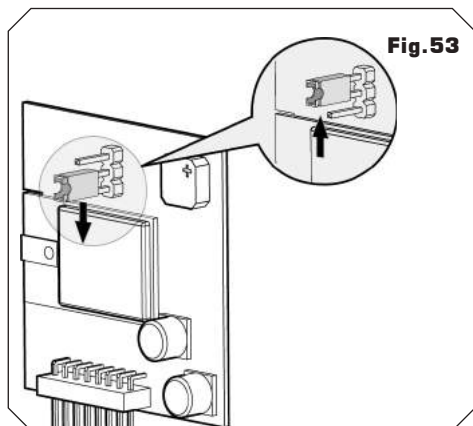
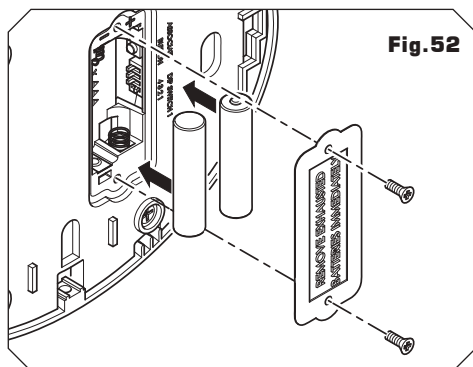
Turn on the water supplies to the shower. Switch on the electricity supply at the mains and then turn on the power to the mixing unit at the isolation switch.

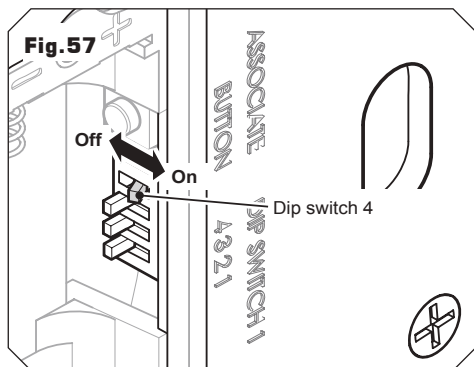
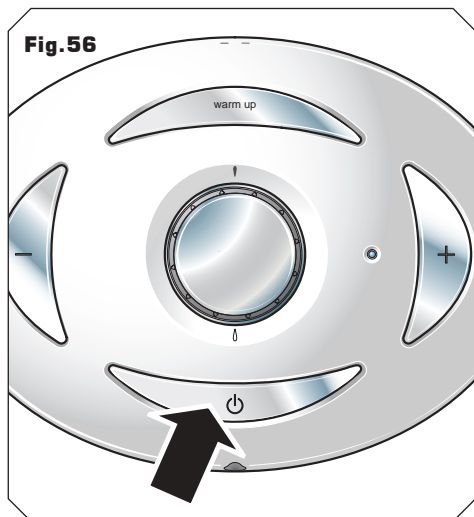
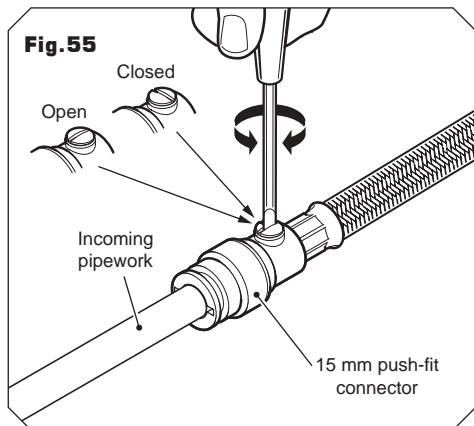
**IMPORTANT:** The mixing unit will start the registration procedure and will beep intermittently for about thirty seconds. Once the mixing unit has completed its registration procedure the intermittent beep will be replaced by a continual tone.

If the mixing unit does not beep, switch off at the mains supply and isolating switch, then remove the cover. To reset the module, move the pin connector across one pin (Fig.53). Refit the cover and switch on the power at the mains and isolating switch – the mixing unit will start its registration procedure.

With the Satellite mixing unit emitting a continual tone, press and hold the 'ASSOCIATE' button (Fig.54) until the LED on the control panel illuminates. Batteries need to be fitted for the Registering procedure to occur. Release the button – the LED will remain illuminated.

When the continual tone stops the LED will extinguish. The control panel and mixing unit are now registered.





## COMMISSIONING

Check that the isolating valves on the inlet connectors are fully open (**Fig. 55**). Turn on the water supplies and check for leaks in the pipework to and from the unit.

The first operation of the shower is to ensure water is purged through the unit. This operation must be carried out with suitable pipework attached to the shower outlet and with the outlet directed to waste.

The control panel is factory set in commissioning mode. To begin the commissioning procedure, press the 'START/STOP' button (**Fig. 56**). Allow the unit to run for five minutes to dispel any air in the system and to prime both supplies to the unit.

**IMPORTANT:** If there is no indication of water dripping or flowing from the showerhead after several minutes then there is probably air still in the unit. To purge the system of trapped air, slacken the threaded part of the 15mm connectors to 'bleed' any air trapped within the unit and then re-tighten. Make sure to 'bleed' all three connectors.

Providing water has entered the unit continue with the commissioning procedure.

Press the 'START/STOP' button to stop the flow. Isolate the electrical supply to the mixing unit.

### Low pressure mixing unit only

To finalise the commissioning remove the batteries from the control panel and set dip switch 4 to the 'OFF' position (**Fig. 57**).

**IMPORTANT:** While the unit is in commissioning mode all other shower functionality will be locked out.

### Dip switch settings

At this stage, the feature settings of flow, temperature and showering time can be selected using dip switches 1, 2 and 3.

Refer to **Table C** to determine the function of each dip switch.

### Dip switch 1: Timer setting

Dip Switch 1 (**Fig.58**) allows selection between 20 minutes operation (OFF) and 10 minutes timed operation (ON) of the shower. Timed operation will set up the shower to run for a maximum of ten minutes before automatically shutting down.

### Dip switch 2: Maximum temperature setting

Dip Switch 2 (**Fig.58**) sets the temperature to run between 35°C – 47°C (OFF) or between 35°C – 41°C (ON).

### Dip switch 3: Eco flow setting

Setting Dip Switch 3 (**Fig.58**) to 'ON' sets the unit into 'Eco FLOW' mode.

In 'Eco FLOW' mode the flow setting is set to a fixed flow rate (set by factory) and any adjustment of '+' button or '-' button will have no effect. Switching to this setting will also override any flow capping settings.

### Dip switch 4: Flow regulation setting (Fully modulating combi-boilers and unvented mains systems only)

The control panel is supplied with Dip Switch 4 in the factory set flow position.

If Dip Switch 4 is left in the 'ON' position the 'Eco' flow and user '+/-' flow buttons will be locked out and the mixer unit will provide a fixed flow setting only.

To enable the 'Eco' flow or '+/-' flow buttons, set Dip Switch 4 to the 'OFF' position.

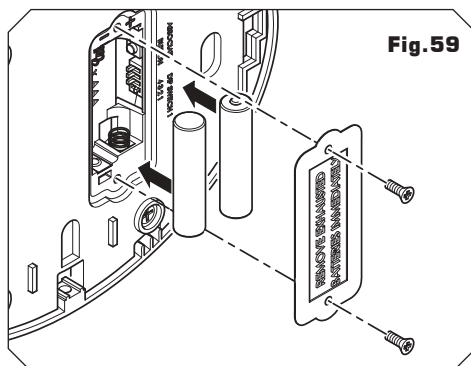
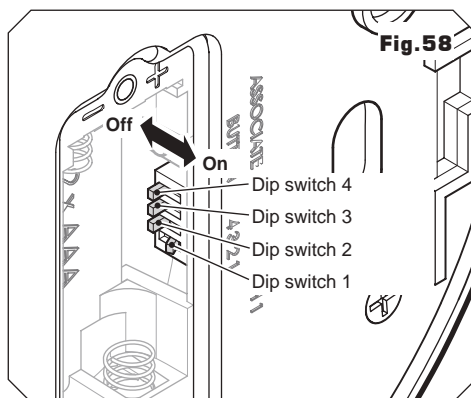
**IMPORTANT:** If the combi-boiler is a step-modulating type (i.e. it does NOT provide a stable output temperature under changing flow rates) then Dip Switch 4 MUST be left in the 'ON' position.

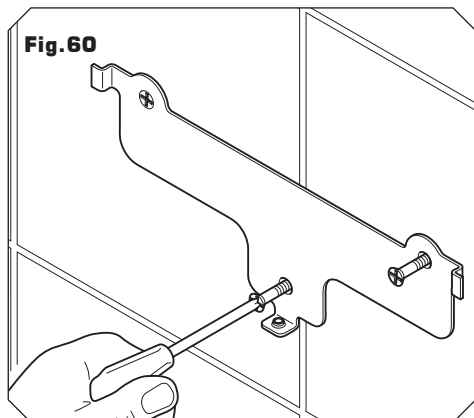
### Important notes on dip switches

1. Dip Switch 4 overrides Dip Switch 3 at all times.
2. Dip Switch 3 overrides flow control and flow capping is disabled.
3. Dip Switch 4 'ON' is the normal running state for step modulating combi-boiler sites with HP units and also overrides the flow capping.

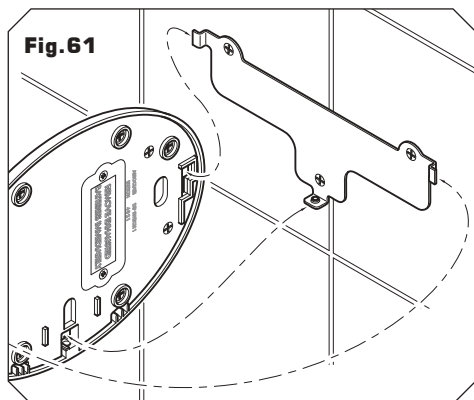
Dip switch	Low pressure settings	High pressure settings
1 on 1 off	Run time set @ 10 Run time set @ 20	Run time set @ 10 Run time set @ 20
2 on 2 off	Temp range 35 - 41°C Temp range 35 - 47°C	Temp range 35 - 41°C Temp range 35 - 47°C
3 on 3 off	ECO mode set to 'ON' Full flow control	ECO mode set to 'ON' if DIP 4 set to 'OFF' Full flow control if DIP4 set to 'OFF'
4 on 4 off	Commissioning Normal operation	Flow set at number 10 (combi flow) Normal operation

Table C

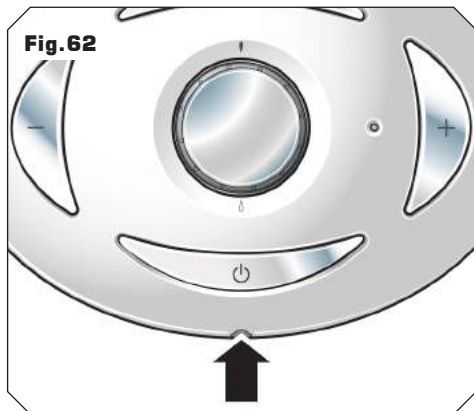




**Fig. 60**



**Fig. 61**



**Fig. 62**

Having selected the preferred settings, refit the batteries, fit the battery cover (**Fig. 59**) and turn the electrical supply back on.

**IMPORTANT:** Make sure to fit the batteries correctly otherwise the circuit board will be damaged.

## INSTALLING THE CONTROL PANEL

### Fitting the control panel bracket

**IMPORTANT:** If installing onto a tiled wall always mount the remote control on the surface of the tiles. NEVER tile up to the remote control.

Decide upon the location of the remote control. Align the mounting bracket on the wall and mark the location of the three fixing holes.

Drill and plug the wall.

*(An appropriate drill bit should be used. If the wall is brick, plasterboard or a soft building block, appropriate wall plugs and screws should be fitted).*

Secure the mounting bracket to the wall (**Fig. 60**).

**Note:** The mounting bracket MUST be fitted on the surface of the tiles.

### Fitting the control panel to the wall

**IMPORTANT:** Refer to the 'Registering the Shower Unit', 'Commissioning' and 'Operating functions' sections before fitting the control panel to the wall.

Hook the control panel over the lugs on the mounting bracket (**Fig. 61**) and slide into place. Secure with the single screw at the bottom of the control panel (**Fig. 62**).

**Note:** To remove the panel, undo the single retaining screw and lift from the wall bracket lugs.



## FAULT FINDING

Problem/Symptom	Cause	Action/Cure
<b>5</b> Shower stops operating after ten minutes.	<b>5.1</b> Timer operation switched on.	<b>5.1.1</b> Check timer setting. See <i>'Operating functions'</i> for further details.
<b>6</b> Shower stops operating after twenty minutes.	<b>6.1</b> Factory set maximum showering time.	<b>6.1.1</b> Restart the shower by pressing the 'Start' button.
<b>7</b> Shower stops after undefined time.	<b>7.1</b> Loss of either water supply.	<b>7.1.1</b> Check water elsewhere in the house and, if necessary, contact the local water company.
<b>7.1.2</b> Check that water is available to the shower when other outlets are in use.	<b>7.2</b> Hot water supply temperature below 35°C.	<b>7.2.1</b> Wait for stored water to reach normal temperature.
<b>7.3</b> Temporary loss of communication.	<b>7.3.1</b> Restart the shower. If the problem persists contact Customer Service.	
<b>8</b> Low flow rates.	<b>8.1</b> Eco flow setting switched on.	<b>8.1.1</b> Check Eco flow setting. See <i>'Operating functions'</i> for further details.
<b>8.2</b> capped settings too low.	<b>8.2.1</b> Check capped settings and, if necessary, reset.	
<b>8.3</b> Control panel in commissioning mode (LP unit only).	<b>8.3.1</b> Check Dip Switch 4 is set to 'off'.	
<b>8.4</b> Restrictions in water supply pressure and flow rates.	<b>8.4.1</b> Check available pressure and flow rates to the mixer unit outlets.	
<b>9</b> No control over water flow or temperature.	<b>9.1</b> Unit in commissioning mode (LP unit only).	<b>9.1.1</b> Check commissioning mode settings are correct. See <i>'Commissioning'</i> for further details.
<b>10</b> LED indicator light flashing every 4 seconds.	<b>10.1</b> Batteries running low.	<b>10.1.1</b> Fit new batteries.
<b>11</b> LED indicator illuminated and unit switches itself off.	<b>11.1</b> Interference with wireless signal.	<b>11.1.1</b> If the problem persists re-register the control panel to the mixing unit. See installation guide: <i>'registering the shower unit'</i> .

## FAULT FINDING

**IMPORTANT:** Switch OFF the electricity at the mains supply and remove the circuit fuse before attempting any fault finding inside the unit.

### Problem/Symptom Cause

### Action/Cure

- |   |   |
|---|---|
| <p><b>1</b> Shower inoperable, no water flow.</p> | <p><b>1.1</b> Interrupted power supply.</p> |
|---|---|

- |   |  |
|---|--|
| <p><b>1.1.1</b> Blown fuse or circuit breaker. Check supply. Renew or reset fuse or circuit breaker. If it fails again, consult a qualified electrician.</p> <p><b>1.1.2</b> Power cut? Check other appliances and, if necessary, contact local Electricity Supply Company.</p> | <p><b>1.2.1</b> Fit new batteries.</p> |
|---|--|

- |  |                                       |
|--|---------------------------------------|
| <p><b>1.2</b> Batteries in control panel need replacing.</p> | <p><b>1.3</b> Blockage in supply.</p> |
|--|---------------------------------------|

- |   |   |
|---|---|
| <p><b>1.3.1</b> Check if isolating valves are fully open. Check if blockage in inlet filters.</p> | <p><b>1.4</b> Blockage in pipework.</p> |
|---|---|

- |   |  |
|---|--|
| <p><b>1.4.1</b> Turn off the shower and consult a suitably competent plumber.</p> | <p><b>1.5</b> Air lock in water supplies (LP unit only).</p> |
|---|--|

- |  |   |
|--|---|
| <p><b>1.5.1</b> Purge air from hot and cold supplies to the connectors on the mixer unit. (Refer to typical suitable installation for details for the correct method of water connection).</p> | <p><b>1.6</b> Failure of either water supply.</p> |
|--|---|

- |  |                                     |
|--|-------------------------------------|
| <p><b>1.7.1</b> Have unit checked by suitably qualified electrician or contact Customer Service.</p> | <p><b>1.7</b> Unit malfunction.</p> |
|--|-------------------------------------|

### 2 Water too hot.

- |   |  |
|---|--|
| <p><b>2.1</b> Temperature too high.</p> | <p><b>2.1.1</b> Reduce temperature via rotary temperature control. See <i>operation</i>;</p> |
|---|--|

- |  |  |
|--|--|
| <p><b>2.2</b> Supply temperature above 65°C.</p> | <p><b>2.2.1</b> Set system temperature to a maximum of 65°C.</p> |
|--|--|

### 3 Water too cool or cold.

- |  |  |
|--|--|
| <p><b>3.1</b> Temperature too low.</p> | <p><b>3.1.1</b> Increase temperature via rotary temperature control. See <i>operation</i>;</p> |
|--|--|

- |  |  |
|--|--|
| <p><b>3.2</b> Supply temperature below 50°C.</p> | <p><b>3.2.1</b> Set system temperature to a minimum of 50°C.</p> |
|--|--|

- |   |  |
|---|--|
| <p><b>3.3</b> Water pressure above maximum specified.</p> | <p><b>3.3.1</b> Fit pressure reducing valve.</p> |
|---|--|

- |   |  |
|---|--|
| <p><b>3.4</b> Too much flow through hot water appliance (combi-boiler/thermal store).</p> | <p><b>3.4.1</b> Cap the maximum flow rate through the mixer. See <i>commissioning</i>;</p> |
|---|--|

- |   |   |
|---|---|
| <p><b>3.5</b> Air lock in mixing unit (LP only)</p> | <p><b>3.5.1</b> Prime to remove air from the mixing unit. See <i>commissioning</i>;</p> |
|---|---|

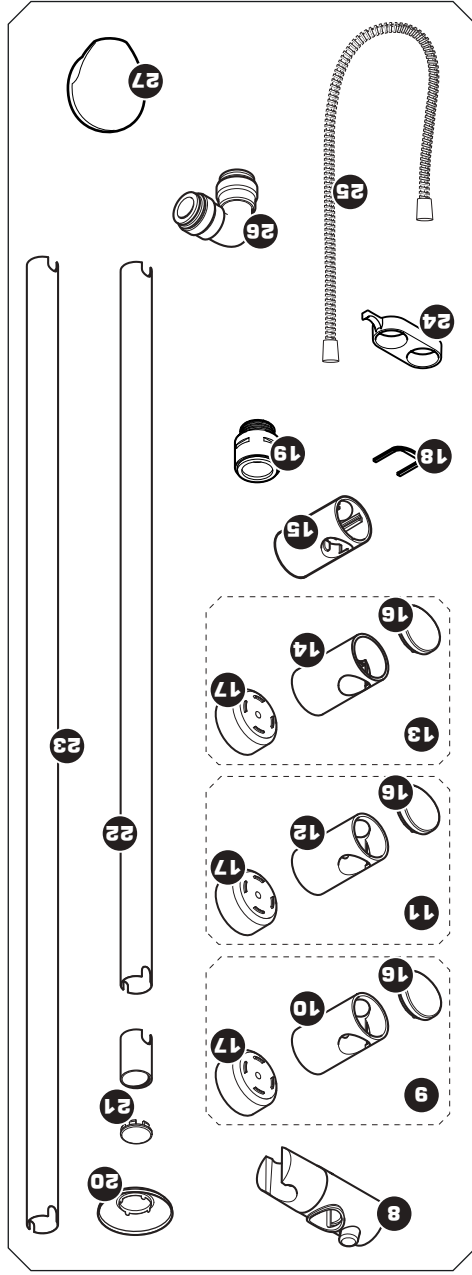
### 4 Noticeable reduction in flow or shower pattern collapses.

- |                                       |  |
|---------------------------------------|--|
| <p><b>4.1</b> Blockage in supply.</p> | <p><b>4.1.1</b> Inspect inlet filters. Clean if necessary. Turn off the shower and consult a suitably competent plumber.</p> |
|---------------------------------------|--|

- |   |   |
|---|---|
| <p><b>4.2</b> Blockage in pipework.</p> | <p><b>4.2.1</b> Turn off the shower and consult a suitably competent plumber.</p> |
|---|---|

- |                                       |  |
|---------------------------------------|--|
| <p><b>4.3</b> Blocked showerhead.</p> | <p><b>4.3.1</b> Clean or replace blocked sprayplate/cartridge.</p> |
|---------------------------------------|--|

**\*SPARE PARTS**



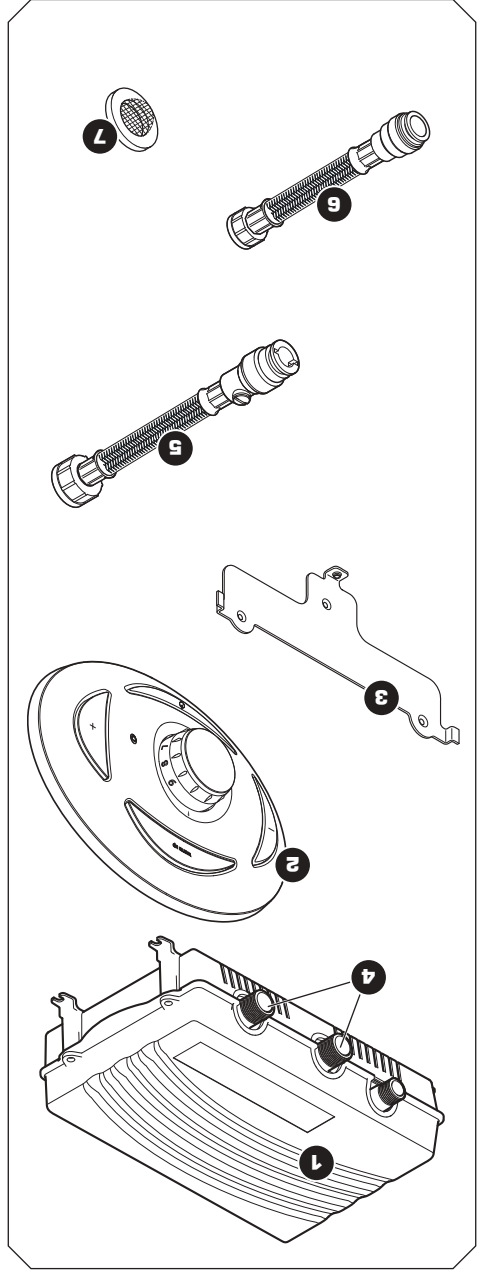
Ref.	Description	Part No.
8.	Showerhead holder	83308410
9.	Bridging bracket assembly (bracket, trim & spacer)	83309970
10.	Bridging bracket	83309450
11.	Guide bracket assembly (bracket, trim & spacer)	83309980
12.	Guide bracket	7053477
13.	Bottom bracket assembly (bracket, trim & spacer)	83309990
14.	Bottom bracket (blank)	7053476
15.	Bottom bracket	
16.	Bracket end trim	83308400
17.	Spacer	7053505
18.	Retaining clip	7053511
19.	Hose connector	7053479
20.	Ceiling trim	22011350
21.	Riser rail section - 40 mm and end trim	7033485
22.	Riser rail section - 700 mm	7033495
23.	Riser rail section - 940 mm	7033484
24.	Hose retainer	83308430
25.	Flexible hoses available in the following sizes:	
	1.00 m in white, chrome and gold	
	1.25 m in white, chrome and gold	
	1.75 m in chrome only	
26.	15 mm push-fit elbow	22011470
27.	Bulkhead assembly	85500230
-	All thread fitting	7032915
-	Shower head (not shown)	

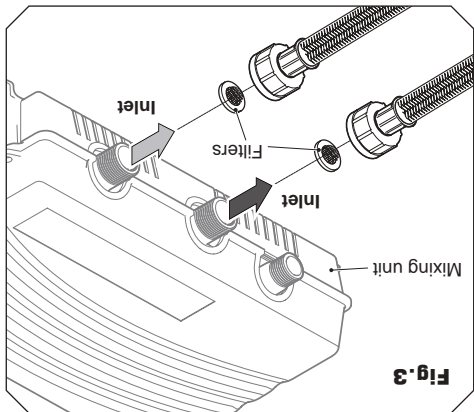


**\*SPARE PARTS**

Ref.	Description	Part No.
1.	Mixing unit Low pressure High pressure	P14430501 P14430500
2.	Control panel	A14430500
3.	Control panel wall bracket	7013533
4.	Check valve (in inlets)	83311080
5.	Flexible hose – incoming (pair)	83311090
6.	Flexible hose – outgoing	83311100
7.	Inlet filter	83311110

All dimensions listed in this fitting book regarding the product and installation are approximate.  
\*All kits are for illustration purposes only and are not supplied unless otherwise stated.





### Cleaning the filters

Turn off the water supplies before starting. To gain access to the filters unscrew the inlet connectors from the mixing unit. Remove the filter from the connector (**Fig. 3**) and wash the filter thoroughly under running water to remove all debris. Replace the filter into the recess in the cap and screw the connector back into each inlet. Should debris enter the check valves in the inlets causing cross flow through the unit it will be necessary to remove the check valves and, if required, replace them.

### Cleaning the check valves

### Important notes on dip switches

1. Dip Switch 4 overrides Dip Switch 3 at all times.
2. Dip Switch 3 overrides flow control and flow capping is disabled.
3. Dip Switch 4 'ON' is the normal running state for step modulating combi-boiler sites with HP units and also overrides the flow capping.

## LOW BATTERY

If the battery is running low then the LED indicator will flash every four seconds while the control panel is on.

**IMPORTANT:** The shower should ALWAYS be switched off at the Start/Stop button before isolating at the electrical isolating switch. Failure to do so will cause the LED indicator to flash for thirty seconds and stay lit for another thirty seconds before extinguishing.

## BATTERY LIFE

The estimated battery life of the control panel, if used on average for ten minutes four times a day, will give an approximate battery life span of 1 year 7 months. This assumes that two 1.5 V alkaline batteries are used.

**Note:** DO NOT use rechargeable batteries in the control panel as these will interfere with the low battery indicator operation.

**IMPORTANT:** If the combi-boiler is a step-modulating type (i.e. it does NOT provide a stable output temperature under changing flow rates) then Dip switch 4 MUST be left in the 'ON' position.

## FEATURE SETTINGS

Refer to **Table C** to determine the function of each dip switch.

### Dip switch 1: Timer setting

Dip Switch 1 (**Fig.2**) allows selection between 20 minutes operation (OFF) and 10 minutes timed operation (ON) of the shower. Timed operation will set up the shower to run for a maximum of ten minutes before automatically shutting down.

**Dip switch 2: Maximum temperature setting**  
Dip Switch 2 (**Fig.2**) sets the temperature to run between 35°C – 47°C (OFF) or between 35°C – 41°C (ON).

### Dip switch 3: Eco flow setting

Setting Dip Switch 3 (**Fig.2**) to 'ON' sets the unit into 'Eco Flow' mode.

In 'Eco Flow' mode the flow setting is set to a fixed flow rate (set by factory) and any adjustment of '+' button or '-' button has no effect. Switching to this setting will also override any flow capping settings.

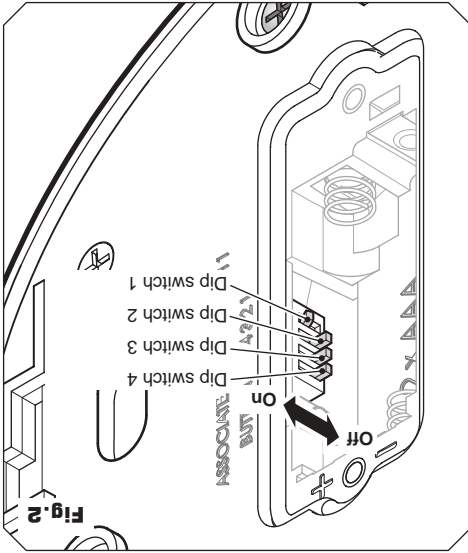
### Dip switch 4: Commissioning setting (Low pressure only)

The control panel is factory set to the commissioning position. Upon completion of the commissioning procedure Dip Switch 4 must be turned 'OFF'.

### Dip switch 4: Flow regulation setting (Fully modulating combi-boilers and unvented mains systems only)

The control panel is supplied with Dip Switch 4 in the factory set flow position. If the Dip Switch 4 is left in the 'ON' position the 'Eco' flow and user '+/-' flow buttons will be locked out and the mixer unit will provide a fixed flow setting only. To enable the 'Eco' flow and '+/-' flow buttons, set Dip Switch 4 to 'OFF'.

**WARNING!**  
Always isolate the electrical supply before replacing the batteries.



**Table C**

Dip switch	Low pressure settings	High pressure settings
1 on	Run time set @ 10	Run time set @ 10
1 off	Run time set @ 20	Run time set @ 20
2 on	Temp range 35 - 41°C	Temp range 35 - 41°C
2 off	Temp range 35 - 47°C	Temp range 35 - 47°C
3 on	Eco mode set to 'ON'	Eco mode set to 'ON'
3 off	Full flow control	Full flow control if DIP 4 set to 'OFF', DIP4 set to 'OFF'
4 on	Commissioning	Flow set at number 10 (combi flow)
4 off	Normal operation	Normal operation

**Note:** If the capping operation has not been set after five minutes, the control panel will return to its normal operation.

adjustments.

and exit capping mode without making any flow settings to the factory defaults, enter

**Note:** To reset the maximum and minimum

has been capped.

will go out and the minimum flow setting

seconds. At this point, the LED indicator

hold the 'Warm up' button for a further five

Once the flow has been adjusted, press and

+', ' button or '-', ' button.

To alter the flow press repeatedly either the

capping mode.

light up to show the control panel is in

+', ' button for five seconds. The LED will

Press and hold the 'Warm up' and the

restricted above the default settings:

The minimum flow of the mixing unit may be

## Minimum Flow

has been capped.

will go out and the maximum flow setting

seconds. At this point, the LED indicator

hold the 'Warm up' button for a further five

Once the flow has been adjusted, press and

flow is achieved.

+', ' button or '-', ' button, until the desired

To alter the flow press repeatedly either the

show the control panel is in capping mode.

for five seconds. The LED will light up to

Press and hold the 'Warm up' and '+' button

may be adjusted from the default settings:

The maximum flow range of the mixing unit

## Maximum Flow

# RESTRICTING THE FLOW FROM THE UNIT

**CAUTION:** It is advisable to be certain that the showering temperature is satisfactory by testing with your hand before stepping under the showerhead. There will always be a time delay of a few seconds between selecting a flow rate and the water reaching the stable temperature for that flow rate.

## Temperature control

The water temperature is altered using the rotary temperature control (Fig. 1).

Rotate the control clockwise; this will increase the temperature of the water up to a maximum at '10' which corresponds to 47°C (41°C if the feature setting has been selected).

Rotate the rotary control anti-clockwise; this will decrease the temperature of the water down to a minimum of '1'. This corresponds to a temperature of 35°C.

Rotating the temperature control fully anti-clockwise to the \* position will select the 'Cold' water setting.

**WARNING!**

This appliance is not intended for use by persons (including children) with reduced physical, sensory or mental capabilities, or lack of experience and knowledge, unless they have been given supervision or instruction concerning use of the appliance by a person responsible for their safety.

Children should be supervised to ensure that they do not play with the appliance.

## OPERATION

**IMPORTANT:** Make sure the commissioning procedure has been carried out. Failure to do so will damage the unit and invalidate the guarantee.

**Fig.1** shows the control panel controls. Switch on the electrical supply to the mixing unit.

### Start/Stop button

Press the 'Start/Stop' button and within a few seconds the LED indicator will illuminate briefly, showing that a button has been pressed, and water will begin to flow.

Pressing the 'Start/Stop' button once again will stop the water flow. Again, the LED will illuminate briefly.

### Warm up button

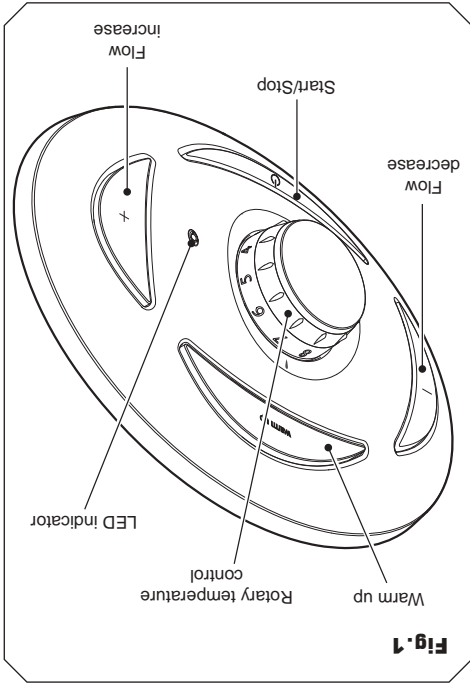
Press and hold the 'Warm up' button until the LED indicator illuminates to start the shower. Water will begin to flow and will continue to flow until the showering temperature has reached the temperature set on the temperature control. At this point the unit will then shut down automatically.

This feature ensures the incoming water supplies are up to their correct temperature and that any cold water in the outlet pipework is removed.

### Flow buttons + -

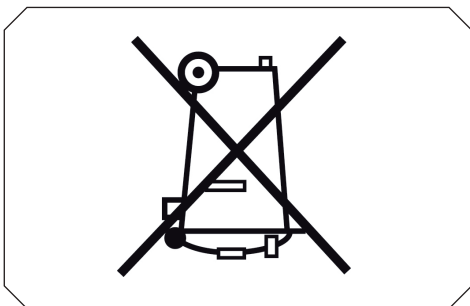
Press the '+' button repeatedly to increase the flow of water from the mixing unit. Repeatedly press the '-' button to reduce the rate of water flow.

The LED will illuminate when either the minimum or maximum flow settings have been reached.



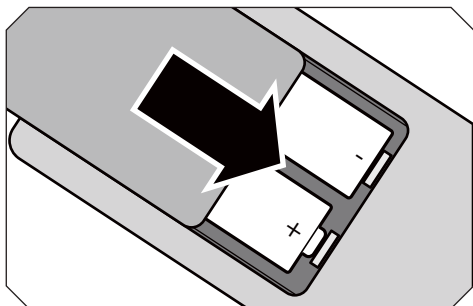
**Fig.1**

Always dispose of batteries in an environmentally friendly manner and in accordance with local regulations.



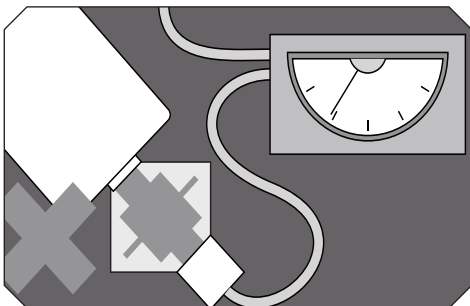
**ALWAYS**

Make sure battery compartments are secure.



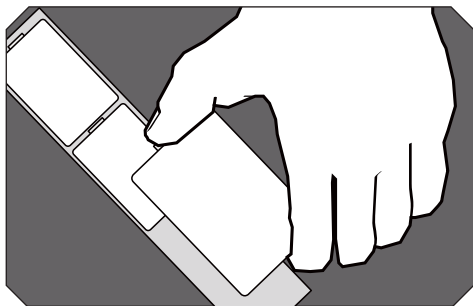
**ALWAYS**

Never attempt to recharge ordinary batteries, either in a charger or by applying heat to them. There are special rechargeable batteries which are marked as such.



**NEVER**

Supervise children if they are replacing batteries themselves in order to ensure these guidelines are followed.



**ALWAYS**

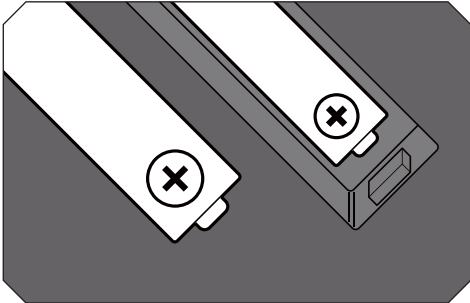


## BATTERY SAFETY GUIDELINES

Used correctly, domestic batteries are a safe and dependable source of portable power. Problems can occur if they are misused or abused – resulting in leakage or, in extreme cases, fire or explosion. Here are some simple guidelines to safe battery use designed to eliminate any such problems.

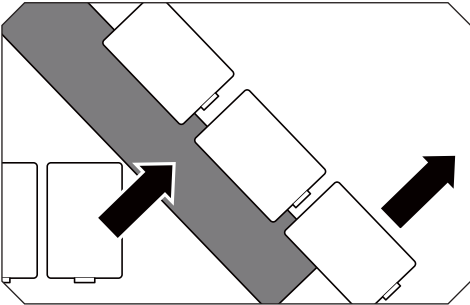
problems.

### ALWAYS



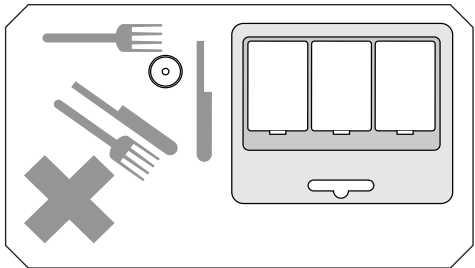
Take care to fit your batteries correctly, observing the plus and minus marks on the battery and appliance.

### ALWAYS



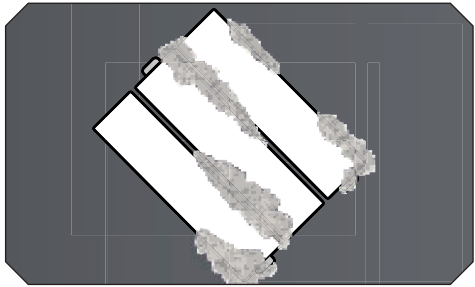
Replace the whole set of batteries at one time, taking care not to mix old and new batteries or batteries of different types.

### ALWAYS



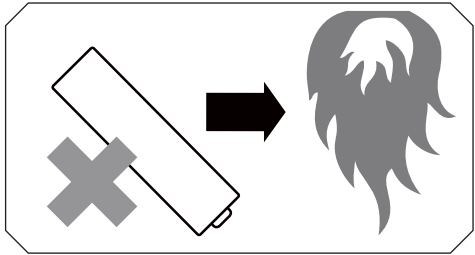
Store unused batteries in their packaging and away from metal objects which may cause a short-circuit.

### ALWAYS



Remove dead batteries from equipment and all batteries from equipment you know you are not going to use for a long time. Otherwise the batteries may leak and cause damage.

### NEVER



Never dispose of batteries in fire as this may cause them to explode.

## SPECIFICATIONS

	High pressure unit	Low pressure unit	Remote control unit
<b>Duty cycle</b>	30 minutes on 30 minutes off	30 minutes on 30 minutes off	-
<b>Electrical</b>	230V 50HZ 5 Amps	230V 50HZ 5 Amps	Nominal power – 3V dc from alkaline batteries
<b>Water</b>	Inlet connections 15 mm push-fit connectors	Inlet connections 15 mm push-fit connectors	-
<b>Water pressures</b>	Maximum static 1000 kPa (100 m head)	Maximum static 100 kPa (10 m head)	-
	Maximum running 500 kPa (50 m head)	Maximum running 100 kPa (10 m head)	-
	Minimum running 100 kPa (10 m head)	Minimum running 1 kPa (0,1 m head)	-
<b>Water temperature requirements</b>	Recommended maximum 65°C	Recommended maximum 65°C	-
	Minimum hot water temperature 52°C	Minimum hot water temperature 52°C	-
	Maximum cold water temperature 20°C	Maximum cold water temperature 20°C	-
<b>Temperature adjustment range</b>	35 to 47°C (Max temperature can be adjusted to 41°C setting)	35 to 47°C	-
<b>Material</b>	ABS	ABS	ABS
<b>Dimensions (in mm)</b>	Height 210 Width 355 Depth 100	Height 210 Width 355 Depth 100	Height 139 Width 199 Depth 46
<b>Splashproof rating</b>	IPX4	IPX4	IPX4

## CONTENTS

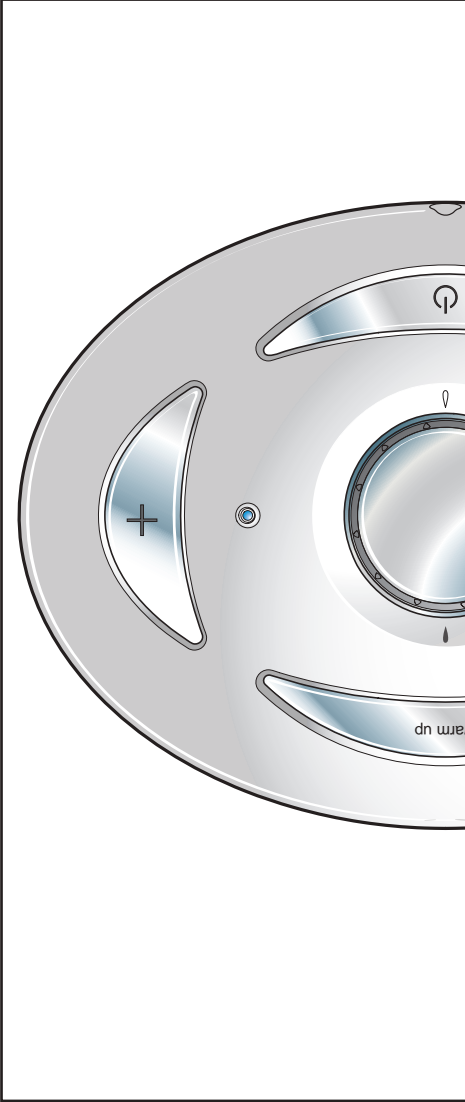
### Page

Specifications .....	1
Battery safety guidelines .....	2 - 3
Operation .....	4 - 5
Restricting flow from the unit .....	6
Feature settings .....	7
Low battery .....	8
Battery life .....	8
Spare parts .....	10 - 11
Fault finding .....	12 - 13

To check the product suitability for commercial and multiple installations, please contact Triton's specification advisory service before installation.  
Telephone: 0844 980 0730  
Facsimile: 0844 980 0744  
E mail: [technical@tritonshowers.co.uk](mailto:technical@tritonshowers.co.uk)

INSTALLERS PLEASE NOTE THESE INSTRUCTIONS ARE TO BE LEFT WITH THE USER

# Operation instructions



**SATELLITES**  
 High performance  
 mixer shower with  
 remote control

SATELLITES  
 by TRITON

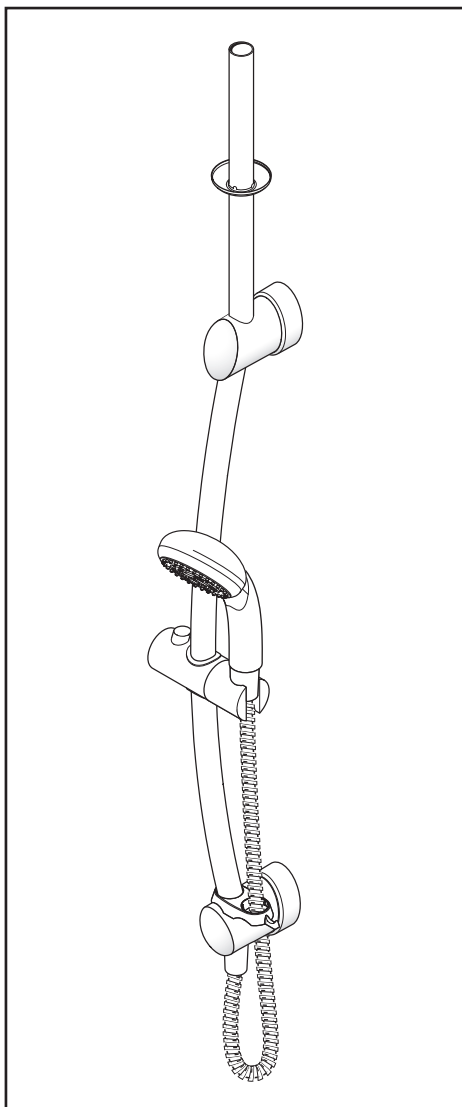


SATELLITES  
by TRITON

**TRITON**

# CARLOVA

## Riser rail kit



## Installation instructions

INSTALLERS PLEASE NOTE THESE INSTRUCTIONS ARE TO BE LEFT WITH THE USER

**CONTENTS** **Page**

---

General installation notes	1
Main components	2
Installation options	3
Installation Option 1: Rear entry supply	4
Components	4
Fitting the riser rail	5
Falling supply — General	7
Installation Option 2: Falling supply — Through the ceiling riser rail	8
Components	8
Fitting the through ceiling riser rail	9
Procedure	9
Plumbing connections	11
Option 1: Rear entry supply — Fitting the bulkhead	11
Option 2: Falling supply — Fitting the outlet connector	12
Fitting the hose and showerhead	13
Adjusting the showerhead	14
Cleaning the showerhead	15
Spare parts	16

To check the product suitability for commercial and multiple installations, please contact Triton's specification advisory service before installation.

Telephone: 0870 067 3767

Facsimile: 0870 067 3334

E mail: [technical@tritonshowers.co.uk](mailto:technical@tritonshowers.co.uk)

## GENERAL INSTALLATION NOTES

The following notes are given as the suggested steps for installing the Satellites mixer shower and remote control:

### 1. Site survey

Determine the position of all parts of the shower (kit, mixing unit and control) before starting the installation.

### 2. Fit the mixing unit

### 3. Install the appropriate riser rail

Having determined the position of the mixing unit, decide on which riser rail kit to use. Option 1 is for rear supply; Option 2 and Option 3 are for a falling supply.

### 4. Install the pipework and plumbing

Run the pipework from the mixing unit to the chosen outlet. The rear supply will terminate at the bulkhead position, while a falling supply will terminate in the loft at the top of the riser rail. Connect the inlet pipework, the outlet pipework and then the outlet fittings.

### 5. Electrical connections

Connect the mixing unit to the electrical supplies.

### 6. Register the remote control panel

Register the control panel to the mixing unit.

### 7. Commission the unit

Commission the shower and select the desired feature settings.

### 8. Fit the control panel to the wall

Install the remote control panel wall mounting bracket within the showering area. Fit the control panel onto the bracket.

### 9. Operation

Operate the shower and set preferred flow settings.

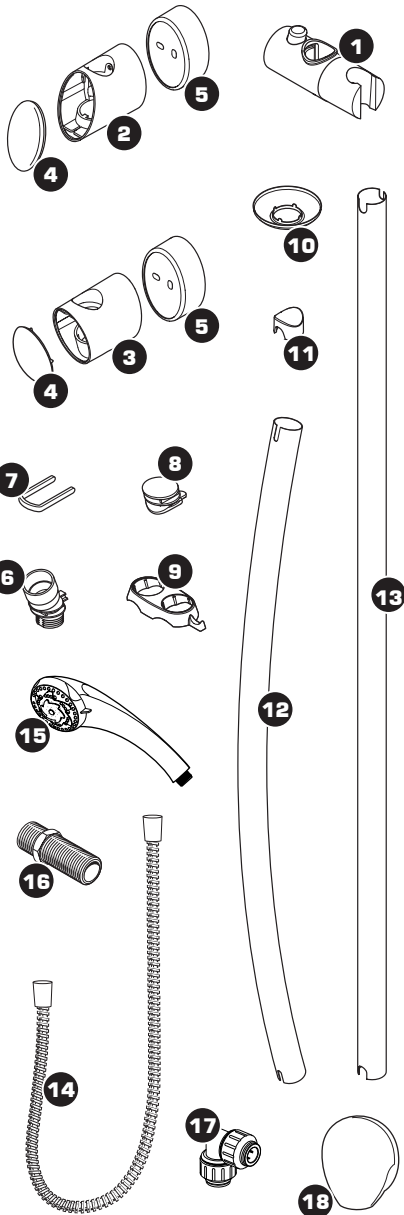
**A video detailing the installation of the Satellites mixer shower can be seen at**

**[www.tritonshowers.co.uk](http://www.tritonshowers.co.uk)**

**A DVD is also available on request.  
Contact the Brochure request line for details on**

**024 7632 4460**

Fig. 1



## MAIN COMPONENTS

### Riser rail contents (Fig. 1)

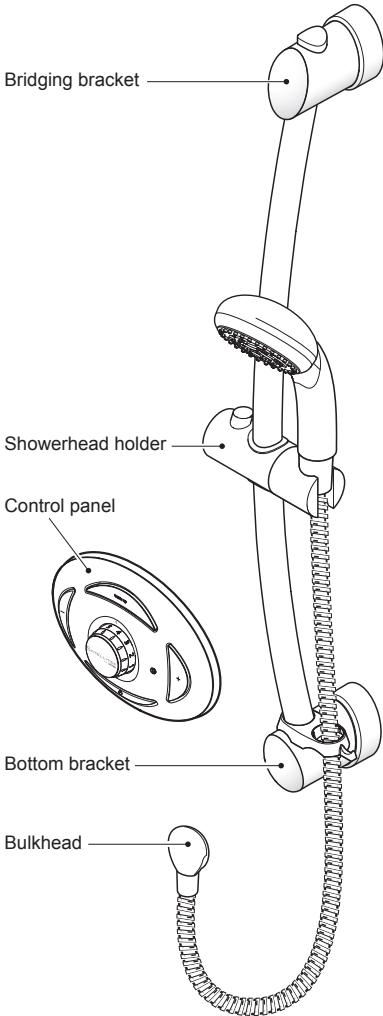
1. Showerhead holder
2. Bridging wall bracket
3. Bottom bracket
4. Bracket trim (2 off)
5. Bracket spacer (2 off)
6. Heated water pipe hose connector
7. Water outlet fitting retaining clip
8. Bottom bracket blanking plug
9. Hose retainer
10. Ceiling trim
11. Riser rail end trim
12. Curved riser rail
13. Riser rail – 940 mm
14. Flexible hose
15. 5 position rub clean showerhead
16. All thread fitting
17. 15 mm push-fit elbow
18. Outlet bulkhead
19. Fixing screws and wall plugs (not shown)

Instructions, guarantee, template etc.



## INSTALLATION OPTIONS

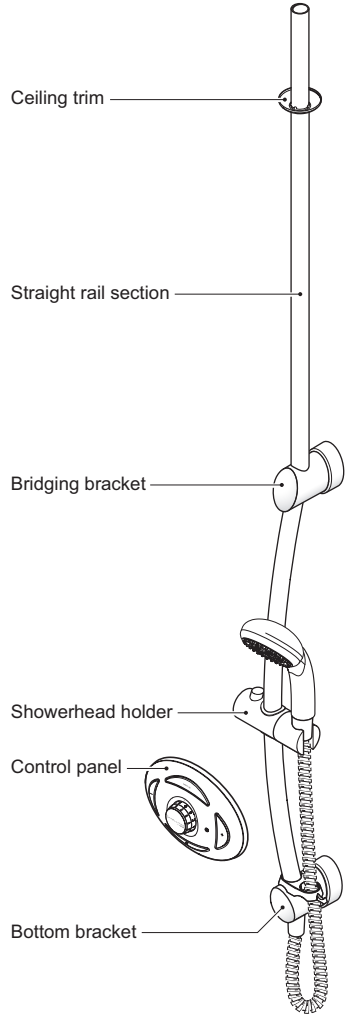
**Fig.2** *Rear entry supply*



### Rear entry supply – Option 1

The control panel is installed onto a tiled wall. The mixing unit is behind an adjoining wall with heated water pipe running to bulkhead (**Fig.2**). Stand-alone riser rail assembly.

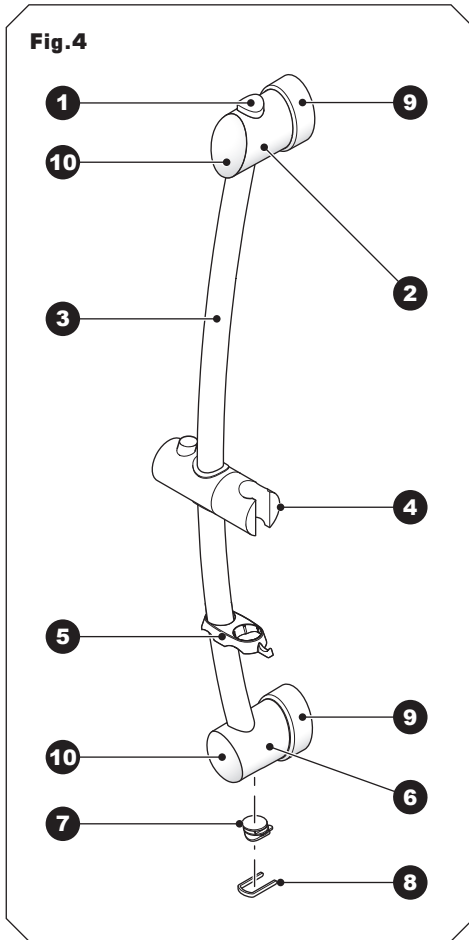
*Falling supply* **Fig.3**



### Falling supply – Option 2

Here the mixing unit is installed in the loft with the heated water pipe running down the inside of the riser rail. Water outlet at the bottom of the riser rail (**Fig.3**).

## INSTALLATION OPTION 1: REAR ENTRY SUPPLY



### COMPONENTS

This option is for installing the riser rail for use with the bulkhead fitting.

**Fig.4** shows the parts required to install the stand-alone riser rail kit.

1. Riser rail end trim
  2. Bridging bracket
  3. Curved riser rail section
  4. Showerhead holder
  5. Hose retainer
  6. Bottom bracket
  7. Blanking plug
  8. Securing clip
  9. Spacer (optional) x2
  10. Bracket end trim x2
- Screws and fittings

**FITTING THE RISER RAIL**

**WARNING!**

**The edges of the riser rail are extremely sharp. Take care when handling and cutting the rails.**

Follow the original instructions for installing the control panel and bulkhead before fitting the riser rail.

Decide the position for the rail on the wall within the shower area. Proceed as follows:

Offer the bottom bracket to the wall and mark the two locating holes. The holes are elongated to allow a small amount of adjustment. Drill and plug the wall. *(The wall plugs provided are suitable for most brick walls – use an appropriate masonry drill, but if the wall is plasterboard or a soft building block, you must use suitable wall plugs and a suitable drill bit).*

Secure bottom bracket *(and spacer)* to the wall using the screws supplied **(Fig.5)**.

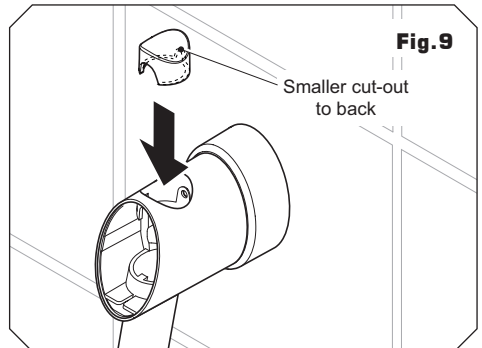
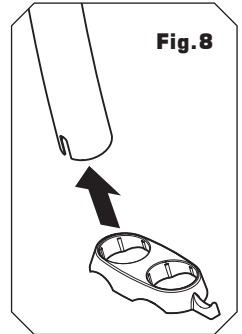
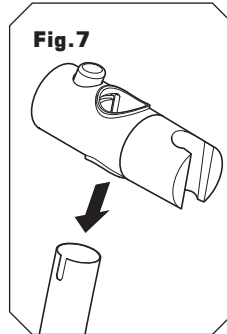
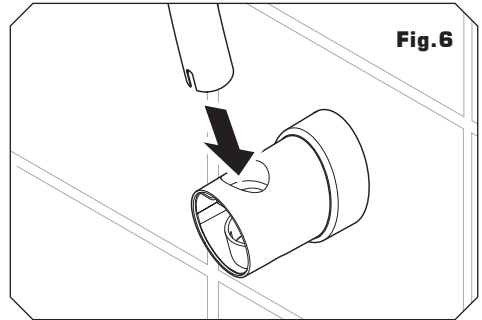
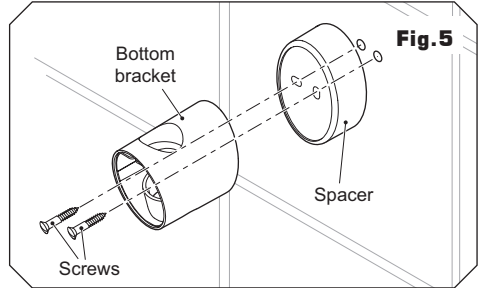
Locate the curved riser rail section onto the bottom bracket, making sure the rail engages fully into the bracket **(Fig.6)**.

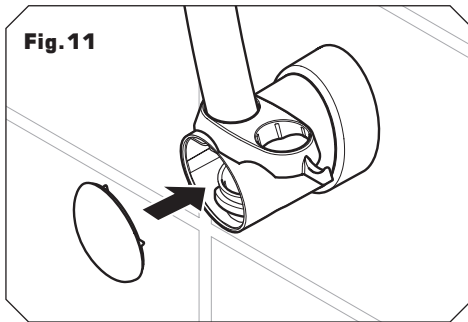
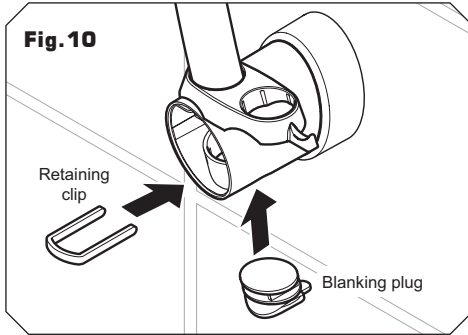
Fit the bridging bracket *(and spacer)* on top of the curved rail and locate against the wall. Align the rail vertically and mark the two locating holes for the bridging bracket. Remove the bracket and rail then drill and plug the wall.

Fit the showerhead holder onto the curved riser rail section – press and hold the button on top of the holder to release the locking mechanism, then slide onto the rail **(Fig.7)**. Release the button to lock the holder in place.

Fit the hose retainer onto the riser rail below the showerhead holder **(Fig.8)**.

Holding the hose retainer in position, fit the curved riser rail and showerhead holder into the installed bottom bracket. Replace the bridging bracket *(and spacer)* onto the rail and secure in place using the screws supplied.





Insert the upper riser rail section into the top of the bridging bracket (**Fig. 9**), making sure the smaller of the cut-outs is towards the rear.

Secure the rail to the bracket using the small screw supplied.

**Note:** The screw will pass through the cut-out in the front of the riser rail and secure the rear of the riser rail against the back face of the bracket.

Insert the blanking plug into the opening in the underside of the bottom bracket and secure in place with the retaining clip (**Fig. 10**).

Push fit the bracket end trims onto the brackets (**Fig. 11**).

## FALLING SUPPLY – GENERAL

### Heated water pipe routed inside the riser rail

This option is for installing a through the ceiling riser rail for use with a falling supply.

**IMPORTANT:** Use the following instructions after installing the mixing unit and when plumbing the unit.

**IMPORTANT:** Before drilling holes in the ceiling or wall surface make sure there is enough clearance above the ceiling to accommodate the entry of the riser rail and heated water pipe.

If the mixing unit is installed in a loft area the following requirements must be met for future servicing purposes:

- a. There must be no risk of the mixing unit or heated water pipe becoming frozen.
- b. The mixing unit **MUST NOT** be covered with any form of insulating material that may give rise to electrical circuits overheating during periods of high ambient temperature.
- c. A safe means of access must be provided into the loft, e.g. via a fixed loft ladder.
- d. The mixing unit **MUST** be installed in an accessible and safe location.
- e. Ceiling joists must be adequately boarded to provide safe and unobstructed access to, from and around the mixing unit.
- f. There must be adequate lighting in the loft for servicing purposes.

### **WARNING!**

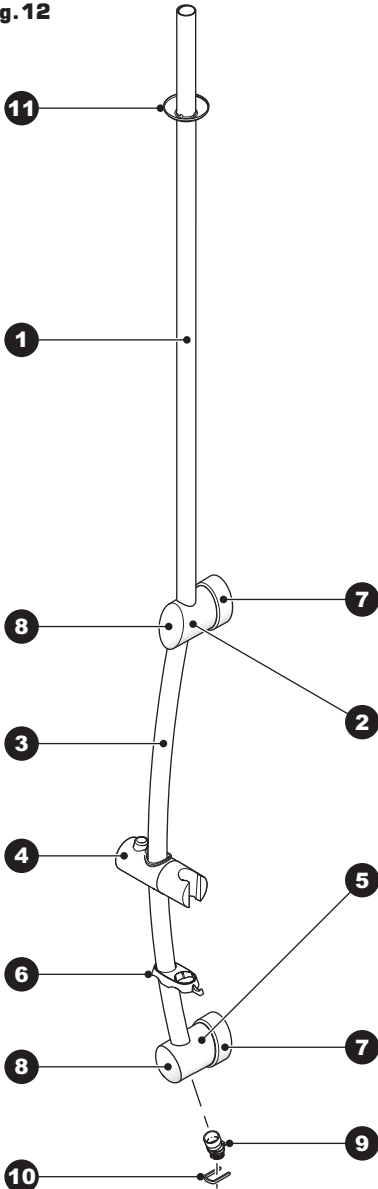
**Check there are no hidden cables or pipes before drilling holes for wall plugs. Use great care when using power tools near water. The use of a residual current device (RCD) is recommended.**

### **WARNING!**

**The edges of the riser rail are extremely sharp. Take care when handling and cutting the rails.**

## INSTALLATION OPTION 2: FALLING SUPPLY — THROUGH THE CEILING RISER RAIL

Fig. 12



### COMPONENTS

Fig. 12 shows the parts required to install the through the ceiling riser rail kit.

1. 940 mm riser rail
2. Bridging bracket
3. Curved riser rail
4. Showerhead holder
5. Bottom bracket
6. Hose retainer
7. Spacer x2
8. Bracket end trim x2
9. Outlet connector
10. Securing clip
11. Ceiling trim

Screws and fittings

**FITTING THE THROUGH CEILING  
RISER RAIL**

**Note:** The straight length of riser rail is supplied to cater for differing ceiling heights. It may be necessary to shorten the rail using a suitable hacksaw or pipe cutter.

**DO NOT shorten the curved rail.**

**WARNING!**

**The edges of the riser rail are extremely sharp. Take care when handling and cutting the rails.**

When determining your required riser rail length allow a minimum distance of 50 mm between the ceiling and the bridging bracket. Make sure there is sufficient length of riser rail above the ceiling level to overcome any obstructions to running the heated water pipe, such as the height of the ceiling joist **(Fig. 13)**.

**Note:** Spacers are supplied to provide an additional 25 mm of depth for the riser rail installation **(Fig. 13)**.

**PROCEDURE**

Assemble the bottom and bridging brackets onto the curved rail.

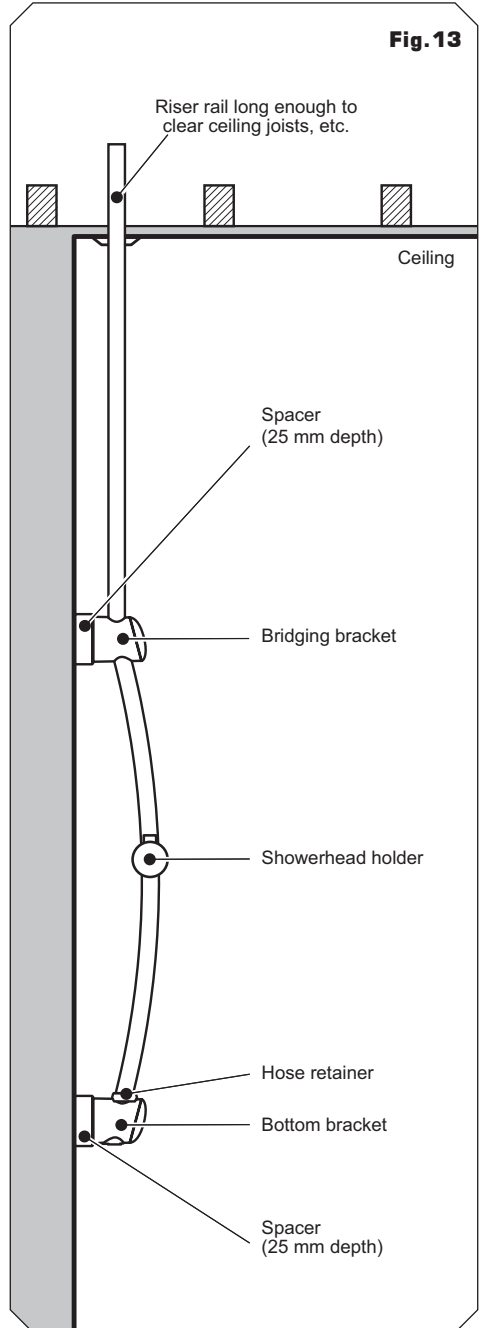
Hold the riser rail assembly up to the wall and align vertically to determine the height of the showerhead and control panel when installed. Mark the position of the bridging bracket then remove the assembly.

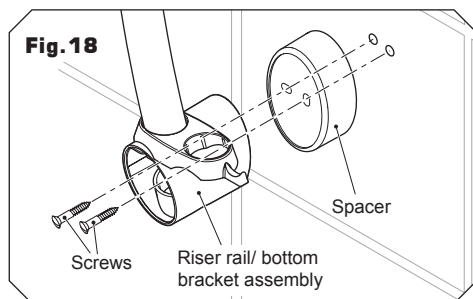
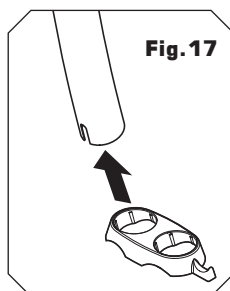
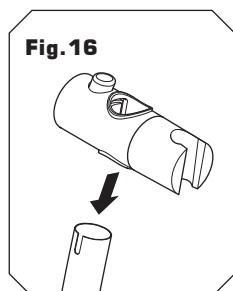
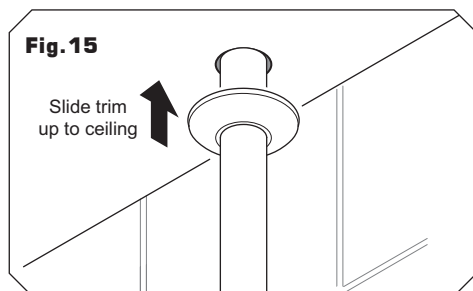
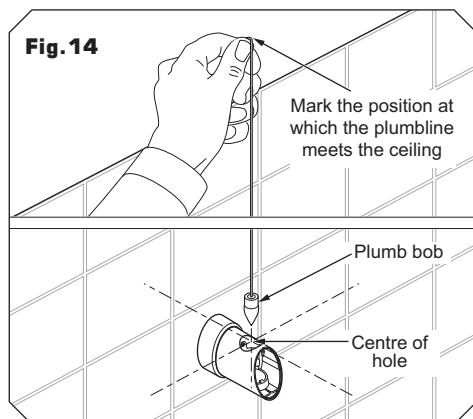
Drill and plug the wall. Secure the bridging bracket *(and spacer, if used)* to the wall.

Using a plumb line and plumb bob, determine the centre position of the hole to be drilled in the ceiling. Hold the plumb line against the ceiling and adjust until the plumb bob hangs directly over the centre of the bridging bracket hole **(Fig. 14)**.

Mark the ceiling at the point at which the plumb line intersects.

Using a 26 mm hole cutter, drill the ceiling opening.





Measure the straight riser rail and mark the required length to fit between the bridging bracket and through into the ceiling. Remember to add the extra length of rail onto the measurements to clear any obstructions above the ceiling level (**Fig. 13**).

Cut the riser rail to length.

If necessary, remove the bridging bracket to allow the rail to be passed up through the hole in the ceiling. Fit the ceiling trim onto the straight riser rail and engage the rail into the bridging bracket, making sure the cut-out engages the bracket lug. Fit the rail into the ceiling and secure the bridging bracket to the wall. Slide the ceiling trim up against the ceiling (**Fig. 15**).

Assemble the curved riser rail and bottom bracket into the bridging bracket. Using a spirit level, align the riser rail vertically and mark the bottom bracket fixing point onto the wall. Drill and plug the bottom bracket fixing.

Fit the showerhead holder onto the curved riser rail section – press and hold the button on top of the holder to release the locking mechanism, then slide onto the rail (**Fig. 16**). Release the button to lock the holder in place.

Fit the hose retainer onto the riser rail below the showerhead holder (**Fig. 17**).

Holding the hose retainer in position, assemble the curved riser rail and showerhead holder into the bottom bracket. Insert the riser rail and holder assembly into the base of the bridging bracket. Using the screws supplied, secure the bottom bracket (*and spacer*) to the wall (**Fig. 18**).



## PLUMBING CONNECTIONS

**IMPORTANT:** Make sure all pipework connections to and from the mixing unit have been completed before fitting the outlet connector. Refer to 'Part 3: Mixing unit' for details.

### OPTION 1: REAR ENTRY SUPPLY — FITTING THE BULKHEAD

Connect the heated water pipe to a ½" BSP x 15 mm female thread elbow or straight coupler compression fitting (**Fig.19**).

**Note:** This fitting is not supplied as variations in installations requires selection of the most suitable fitting.

Screw the supplied male-thread connector into the female fitting (**Fig.20**) using PTFE tape to give a watertight joint.

**Note:** The male-thread connector supplied has a shoulder. If fitting into a flush wall, make an additional 8 mm allowance for this shoulder at the finished surface. The connector can be cut to size if required.

The threaded connector should protrude from the wall surface between 8 mm and 13 mm.

Make good the wall.

The bulkhead and its cover are supplied assembled. Separate the two halves by carefully prising apart at the smaller of the two elbow apertures.

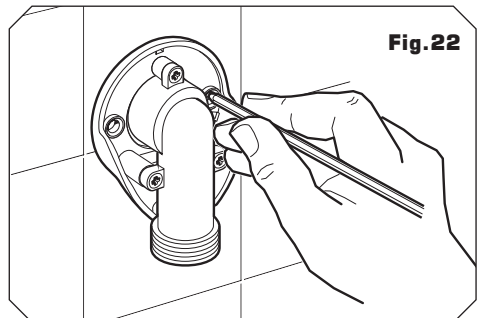
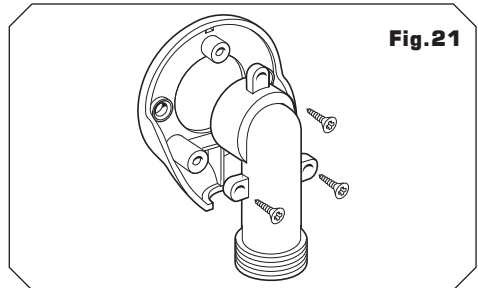
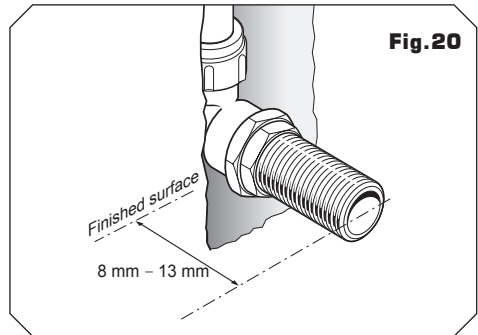
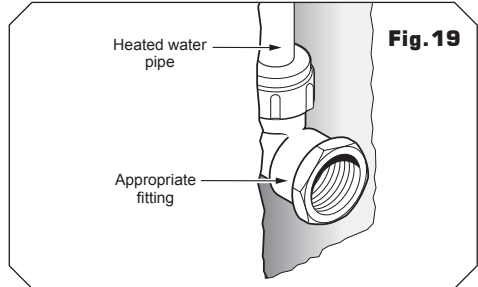
Secure the elbow to the bulkhead body with the three screws supplied (**Fig.21**).

Screw the bulkhead assembly onto the threaded connector temporarily. Mark the position of the two fixing holes (**Fig.22**) securing the bulkhead to the wall.

**Note:** If screw thread protrudes too far out of the wall, it can be cut to the correct length using a hacksaw.

Unscrew and remove the bulkhead assembly. Check the location of the pipe in the wall before drilling.

Drill and plug the holes using the wall plugs supplied. (*The wall plugs provided are suitable*



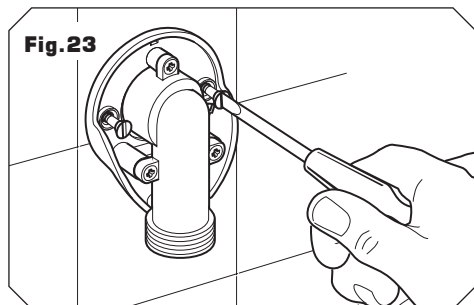


Fig. 23

for most brick walls — use an appropriate masonry drill, but if the wall is plasterboard or a soft building block, you must use suitable wall plugs and an appropriate drill bit).

If fitting to a hollow wall structure, it may be preferable to secure the bulkhead by applying a bead of silicon seal to the back of the bulkhead.

Apply PTFE tape to the threaded connector.

Screw the bulkhead assembly onto the threaded connector until tight to the wall and the two fixing holes are aligned. Secure to the wall with the two screws supplied (**Fig. 23**).

Finish by clipping the cover onto the bulkhead making sure the protruding legs locate in the bulkhead body.

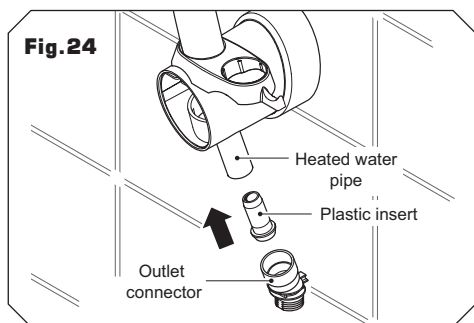


Fig. 24

### OPTION 2: FALLING SUPPLY — FITTING THE OUTLET CONNECTOR

The 15 mm heated water pipe (supplied with the mixing unit) feeds down through the centre of the riser rail. This runs from the push-fit elbow at the top of the riser rail and terminates to the outlet connector at the base of the through ceiling kit. The heated water pipe is connected to the outlet pipework via the 15 mm push-fit elbow.

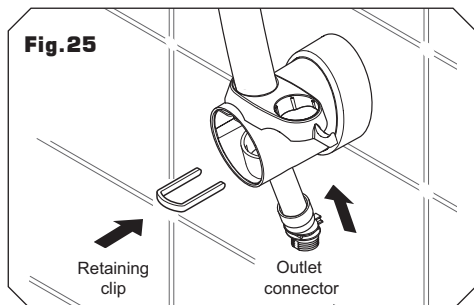


Fig. 25

Fit one of the supplied plastic tube inserts into one end of the water pipe until it is flush. This will provide extra support to the plastic pipe. Push fit the outlet connector onto the heated water pipe (**Fig. 24**).

Feed the heated water pipe and connector back up the rail and secure the connector with the retaining clip (**Fig. 25**).

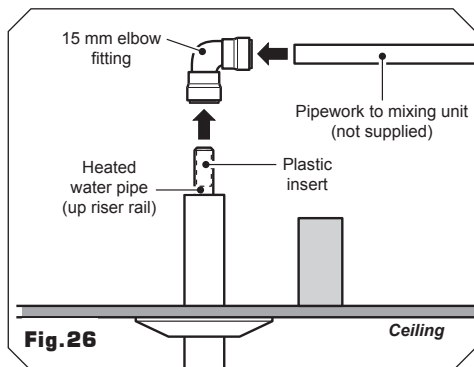


Fig. 26

In the loft, trim the heated water pipe excess to length. Insert the remaining plastic tube insert the end of the water pipe and then push fit into the 15 mm elbow fitting (**Fig. 26**).

Fit the bracket end trims onto the brackets.

## FITTING THE HOSE AND SHOWERHEAD

Feed the flexible hose through the hose retainer opening (**Fig.27**) so that it acts as a retaining ring (*Water Regulations*).

Screw the flexible hose to the bulkhead (**Fig.28**) or the outlet connector (**Fig.29**) and the other end to the showerhead. Make sure the supplied washers are in place at both ends of the flexible hose.

Place the showerhead into the holder and check that it fits correctly.

**Note:** The holder is slightly tapered and the showerhead and hose will only fit from one direction.

**IMPORTANT:** It is the conical end of the hose which grips into the holder. The showerhead will not fit in the holder without the hose attached.

At this stage, disconnect the showerhead and lay aside until the shower unit has been commissioned.

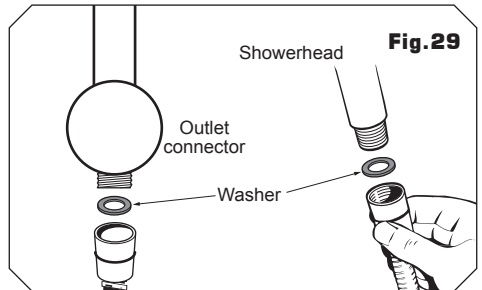
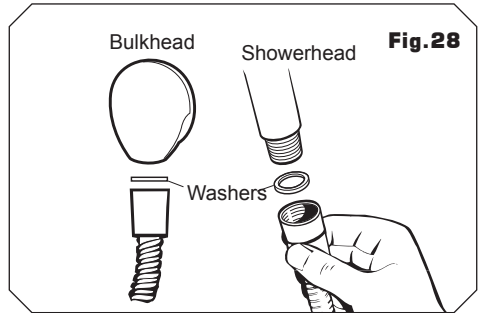
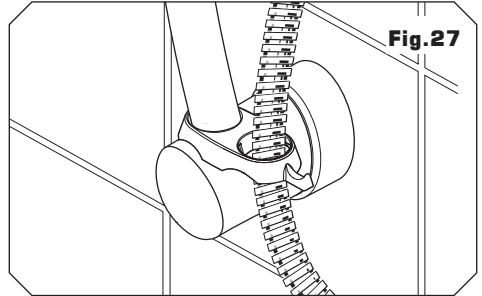
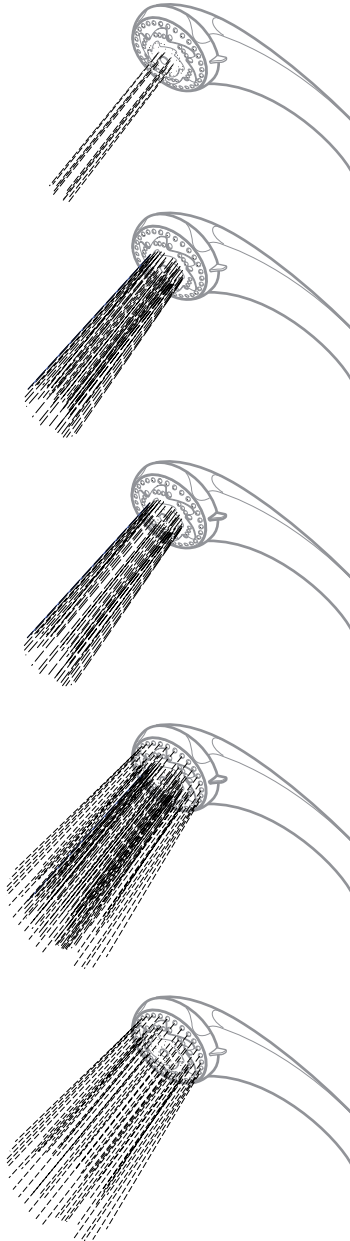


Fig. 30



## ADJUSTING THE SHOWERHEAD

Five showerhead patterns are available (**Fig. 30**). Adjust the spray pattern by turning the bezel on the showerhead in either direction until the desired pattern is obtained.

## CLEANING THE SHOWERHEAD

Before cleaning, turn off the unit at the mains supply to avoid the shower being accidentally switched on.

It is important to keep the showerhead clean to maintain the performance of the shower. The hardness of the water will determine the frequency of cleaning. For example, if the shower is used every day in a very hard water area, it may be necessary to clean the showerhead on a weekly basis.

### SPRAYPLATE REMOVAL

There is no need to remove the showerhead from the hose.

Using the removal tool supplied (**Fig.31**), locate the raised 'bosses' into the recesses in the sprayplate. Hold in firmly and twist anti-clockwise (**Fig.32**). This movement may turn the cartridge assembly as well until it reaches a 'stop'.

Hold the cartridge firmly and continue to twist anti-clockwise. Having loosened the sprayplate, it can be unscrewed and removed completely.

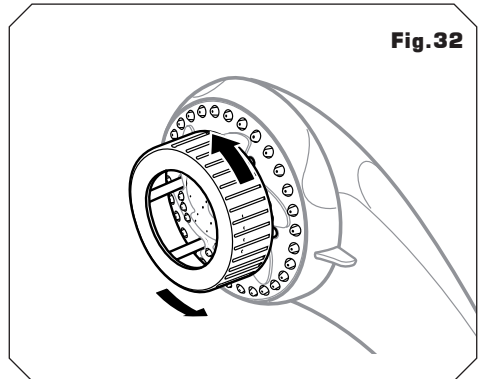
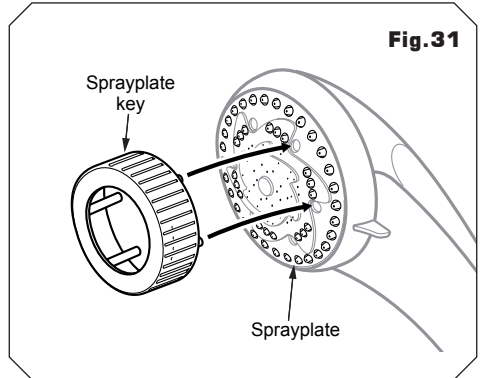
Clean the sprayplate with a suitable brush or preferably leave it to soak overnight in a mild proprietary descaler. Make sure all traces of scale are removed and thoroughly rinse in clean water afterwards.

Before replacing the sprayplate, switch the water and power back on at the mains supply and direct the hose and showerhead to waste.

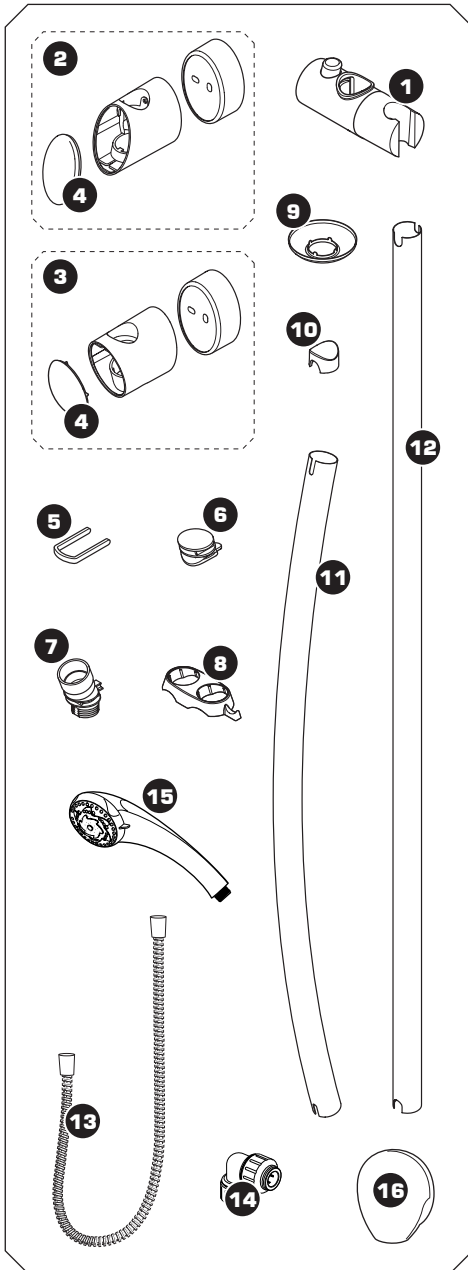
Turn the temperature control to cold.

Start the shower and set to maximum flow. This operation will flush out any loose scale deposits in the unit and showerhead. Stop after about thirty seconds.

Refit the sprayplate by screwing clockwise. Use the tool to screw the sprayplate tight.



**SPARE PARTS**



Ref.	Description	Part No.
1.	Showerhead holder	83308410
2.	Bridging bracket assembly (bracket, end trim & spacer)	83311240
3.	Bottom bracket assembly (bracket, end trim & spacer)	83311250
4.	Bracket end trim	7053514
5.	Retaining clip	7053561
6.	Blanking plug	7053565
7.	Hose connector	86100046
8.	Hose retainer	7053564
9.	Ceiling trim	22011350
10.	Riser rail blanking cap	7053515
11.	Curved riser rail section	7033558
12.	Riser rail section – 940 mm	7033484
13.	Flexible hoses available in the following sizes:	
	1.00 m in white, chrome and gold	
	1.25 m in white, chrome and gold	
	1.75 m in chrome only	
14.	15 mm push fit elbow	22011470
15.	5 mode showerhead	22011110
16.	Bulkhead assembly	85500230
-	All thread fitting	7032915



## **TRITON STANDARD GUARANTEE**

Triton guarantee this product against defects arising from faulty workmanship or materials for a period of one year for domestic use only, from the date of purchase, provided that it has been installed by a competent person in full accordance with the fitting instructions.

Any part found to be defective during this guarantee period we undertake to repair or replace at our option without charge so long as it has been properly maintained and operated in accordance with the operating instructions, and has not been subject to misuse or damage.

This product must not be taken apart, modified or repaired except by a person authorised by Triton.

This guarantee applies only to products installed within the United Kingdom and does not apply to products used commercially. This guarantee does not affect your statutory rights.

Triton Showers  
Triton Road  
Nuneaton  
Warwickshire CV11 4NR

*Triton is a division of Norcross Group (Holdings) Limited*

**Customer Service: ☎ 0870 067 3333**

**Scottish and Northern Ireland**

**Customer Service: ☎ 0845 762 6591**

**Trade Installer Hotline: ☎ 0870 067 3767**

**Fax: 0870 067 3334**

**[www.tritonshowers.co.uk](http://www.tritonshowers.co.uk)**

**E mail: [technical@tritonshowers.co.uk](mailto:technical@tritonshowers.co.uk)**