

TRITON

DENE eco Bar Mixer Shower

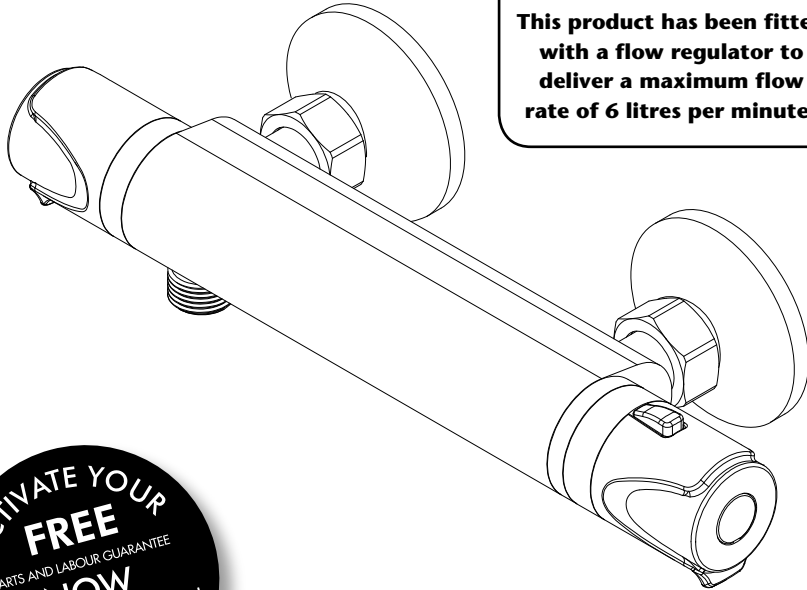

86004420



ECO STATEMENT

This product has been fitted with a flow regulator to deliver a maximum flow rate of 6 litres per minute.



Installation and operating instructions



The showerhead and hose supplied with this product are a safety critical part of your shower. Failure to use genuine Triton parts may cause injury and invalidate your guarantee.



CONTENTS	Page
MAIN COMPONENTS.....	1
INTRODUCTION.....	2 - 3
TYPICAL DOMESTIC INSTALLATIONS.....	4 - 6
INSTALLATION.....	7
Preparing the mixer valve	7
Siting of the shower.....	7
Supply pipework.....	7
Bracket install	8 - 12
Leak testing the mixer	13
COMMISSIONING.....	13
Flow regulation.....	13
To fit the flow regulator	13
TEMPERATURE ADJUSTMENT RANGE.....	14
Recommended outlet temperatures.....	14
Adjusting the maximum temperature setting.....	14
Operating the shower.....	15
Dimensions.....	16
Spare parts	17
APPROVALS	18
TMV2 REQUIREMENTS (12 MONTHLY VERIFICATION).....	18
FLOW CHART	18
MAINTENANCE	19
Fault Finding.....	20 - 21
Guarantee, service policy, etc.....	rear cover

INSTALLERS PLEASE NOTE THESE INSTRUCTIONS ARE TO BE LEFT WITH THE USER

To check the product suitability for commercial and multiple installations, please contact Triton's specification advisory service before installation. Please see back of book for contact information.

E mail: technical@tritonshowers.co.uk

MAIN COMPONENTS

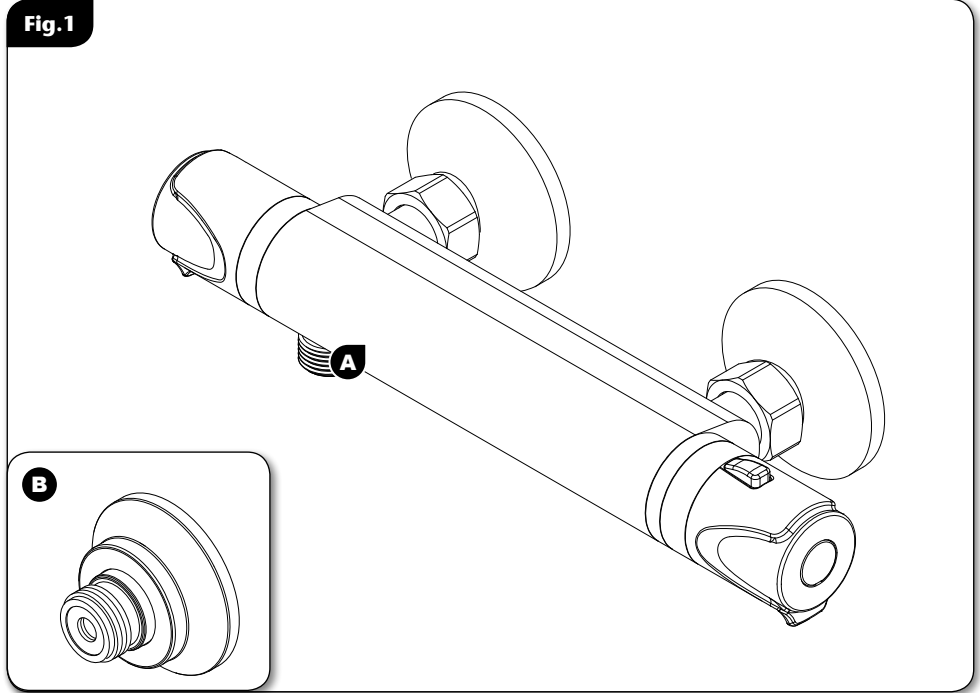

- A.** Thermostatic bar mixer valve
- B.** Push-fit connector X2 (with trims)

All dimensions listed in this fitting book regarding the product and installation are approximate.
*All kits are for illustration purposes only and are not supplied unless otherwise stated.

INTRODUCTION

This book contains all the necessary fitting and operating instructions for your mixer shower. Please read them carefully and read through the whole of this book before beginning your installation.

The shower installation must be carried out by a suitably competent person and in sequence of this instruction book.

Care taken during the installation will give a long and trouble free life from your mixer shower.

SITE REQUIREMENTS

The installation must be in accordance with water supply (water fittings) regulation 1999 and/or local Bylaws.

Water pressure requirements

Running water pressure:

Low pressure*	- 0.1 bar min. 1.0 bar max.
High pressure	- 0.5 bar min. 5.0 bar max.

Maximum static water pressure:

Low & High pressure	- 10 bar
---------------------	----------

*This mixer shower is designed for high pressure systems found in the UK, but can be installed with low pressure gravity water systems with reduced flow rates.

For effective operation of the internal seals, the maximum static pressure must not be exceeded.

Pressure reducing valve

On sites where the running pressure is above 5 bar, the use of a suitably sized pressure reducing valve fitted in the cold mains supply pipe work can provide nominally equal pressures at the mixer shower.

Water minimum flow rate

For best performance within the specified running pressure range a minimum flow of 8 litres per minute should be available to both inlets.

Water temperature requirements

Recommended maximum: = 65°C

Minimum hot water temperature: = 55°C

Maximum cold water temperature: = 25°C

NOTE: Valves operating outside these conditions cannot be guaranteed by the Scheme to operate as Type 2 valves.

A stored water temperature of 60°C is considered sufficient to meet all normal requirements and will minimise the effects of scale in hard water areas.

Water temperature adjustment and thermal safety

The mixed water temperature can be adjusted from cold through to a top limit which must be preset during installation with full anti-scald protection throughout the range (35°C to 40°C) providing the hot water temperature at the inlet remains 10°C above the outlet temperature.

Should there be a loss of flow to either incoming supply then- water from the shower will stop or be reduced until both supplies are restored.

SAFETY WARNINGS

- DO NOT** choose a position where the shower could become frozen.
- DO NOT** connect this mixer shower to any form of tap or fitting not recommended by the manufacturer.
- DO NOT** allow the inlet pressure or flow rates to operate outside the guidelines laid out in 'site requirements'.
- DO NOT** connect the mixer shower to a gravity hot supply and a mains cold supply (or vice versa).

PLUMBING REQUIREMENTS

DO NOT use jointing compounds on any pipe fittings for the installation,

DO NOT solder fittings near the mixer unit as heat can transfer along the pipework and damage the mixer valve.

DO NOT subject the unit to a water temperature above 80°C during installation, use, maintenance or disinfection.

IMPORTANT:

- The layout and sizing of pipework **MUST** be such that nominally equal inlet supply pressures are achieved and the effects of other draw-offs are minimised.
- The pipe-work should be installed such that other taps and appliances being operated elsewhere on the premises do not significantly affect the flow
- When connecting pipe-work avoid using tight 90° elbows; swept or formed bends will give the best performance.
- The hot water pipe entry **MUST** be made to the left-hand side inlet, marked HOT, 'H' or with a red/orange label.
- Suitable isolating valves (complying with Water Regulations and Bylaws) **MUST** be fitted on the hot and cold water supplies to the shower as an independent means of isolating the water supplies should maintenance or servicing be necessary.
- It is preferable to flush the pipe-work to clear the system of debris and check for leaks before connecting to the mixer.
- The mixer inlets contain removable filters that may become blocked if debris is not flushed through before fitting.

(Commercial applications)

- It is recommended that for all commercial applications, easily accessible, in-line filters are used to aid maintenance.

Hard water areas

- a. If it is intended to operate the shower in areas of hard water (above 200-ppm temporary hardness), a scale inhibitor may have to be fitted. For advice on the scale inhibitor, please contact Customer Service.
- b. For best performance the showerhead **MUST** be regularly cleaned to remove scale and debris.

WATER SYSTEM REQUIREMENTS

This mixer shower is suitable for:

- Gravity water systems
- Pumped gravity systems.
- Fully modulating type combination boilers
- Multi-point hot water heaters.
- Thermal storage,
- Unvented systems

When installing this mixer with a Combination or multi-point boiler, it may be necessary to install flow regulation.

Check that the appliance is capable of delivering hot water at a minimum switch-on flow rate of 3 litres per minute. At flow rates between 3 and 8 litres per minute, the appliance **MUST** be capable of raising the water temperature to 52°C (minimum).

Water temperature at the inlet of the mixer valve **MUST** remain relatively constant when flow rate adjustments are made (refer to the appliance-operating manual to confirm compatibility with this mixer shower).

Where thermal store systems and instantaneous gas water heaters are used, if excessive draw-off take place the appliance may not be able to maintain an adequate output temperature. This could result in the shower temperature becoming noticeably cooler.

Flow regulators can be fitted with high-pressure water systems to reduce flow rate and assist economy.

The hot supply temperature **MUST** remain a minimum of 10°C hotter than the required blend temperature for optimum performance.

*Fig.2

*(diagrammatic view – not to scale)

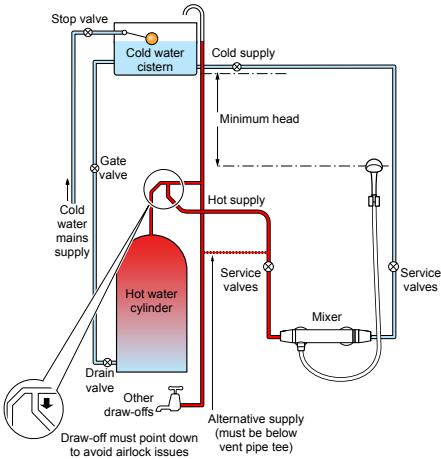

TYPICAL DOMESTIC INSTALLATIONS

Domestic gravity fed systems (fig.2)

The shower control **MUST** be fed from a cold water cistern and hot water cylinder providing nominally equal pressures. There **MUST** be a minimum of one metre head of water. The minimum head distance is measured from the base of the cold water cistern to top of the showerhead.

If valves are gravity fed then supply pressure should be verified to ensure conditions of use are appropriate for the valve.

*Fig.3

*(diagrammatic view – not to scale)

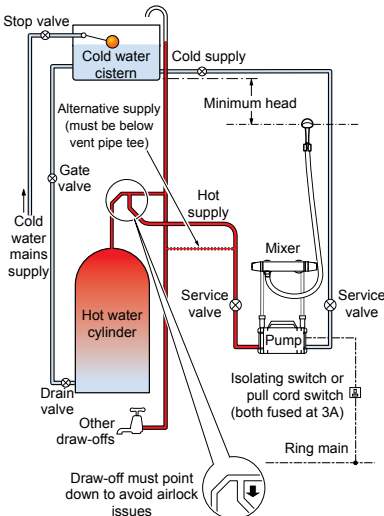

Pumped gravity fed systems (fig.3)

The shower control **MUST** be fed from a cold water cistern and hot water cylinder providing nominally equal pressures.

The mixer may be used with a gravity fed system with a pump to boost pressures as shown; please refer to the pump installation guide to establish the minimum head requirements for automatic operation of the pump

Instantaneous gas-heated systems, e.g. combination boilers (fig.4)

The shower control **MUST** be installed with a multi-point gas water heater or combination boiler of a fully modulating design (i.e. to maintain relatively stable hot water temperatures).

A drop tight pressure reducing valve **MUST** be fitted if the supply pressures exceed 5 bar running.

An expansion vessel **MAY** be fitted, and regularly maintained, to prevent the shower mixer being damaged by excess pressures. This may already be installed within the boiler (check with manufacturer) and is in addition to the normally larger central heating expansion vessel.

Unvented mains pressure systems (fig.5)

The shower control can be installed with an unvented, stored hot water cylinder.

For systems with no cold water take off after the appliance reducing valve, it will be necessary to fit an additional drop tight pressure-reducing valve when the mains pressure is over 5 bar. The drop tight pressure reducing valve **MUST** be set at the same value as the unvented package pressure reducing valve.

Note: An additional expansion vessel may be required if a second pressure-reducing valve is installed. This does not apply to packages with a cold take off after the pressure-reducing valve to the cylinder.

***Fig.4**

**(diagrammatic view – not to scale)*

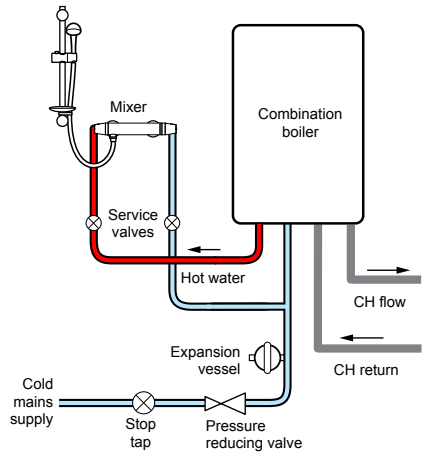

***Fig.5**

**(diagrammatic view – not to scale)*

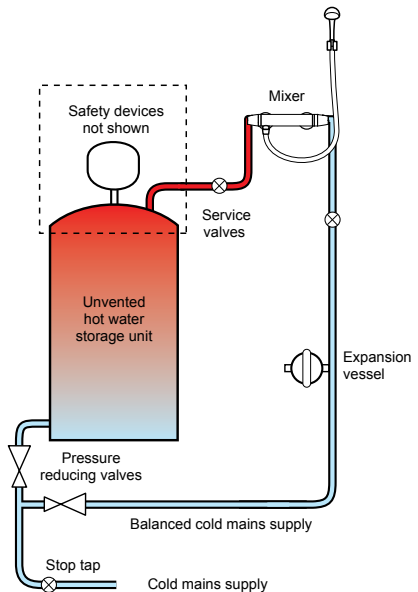

***Fig.6**

**(diagrammatic view – not to scale)*

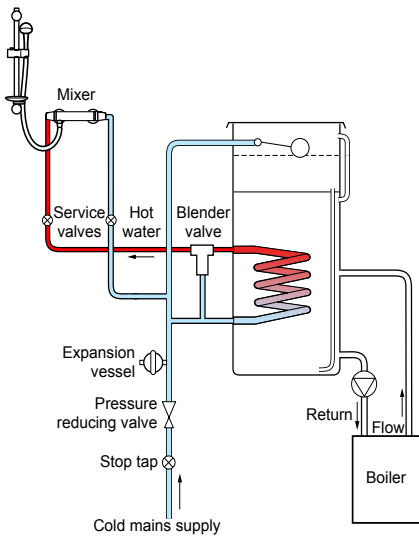

Mains pressurised thermal store systems (fig.6)

Packages of this type, fitted with a tempering valve (blender valve) can be used. A drop tight pressure reducing valve **MUST** be fitted if the supply pressures exceed 5 bar running.

An expansion vessel **MUST** be fitted, and regularly maintained, to ensure, the unit, is not damaged by excess pressures. This may already be installed externally or internally within the thermal store (check with thermal store manufacturer).

INSTALLATION

PREPARING THE MIXER VALVE

Check the contents to make sure all items are present.

Before starting, make sure all of the openings on the valve are carefully covered to stop ingress of any debris, etc. while routing the supply pipework.

The shower valve is suitable for exposed installation onto:

- Solid wall
- Stud partition wall
- Dry lined wall
- Laminate cubicle or panel.

SITING OF THE SHOWER & ACCESSORIES

Refer to **(fig.7)** for correct siting of the shower.

The mixer valve should be positioned, as detailed, with all controls within comfortable reach of the user.

The accessories (showerhead, riser rail and/or fixed showerhead) can be positioned above or to either side of the shower.

The valve must be installed in a position that allows for easy access for future maintenance and commissioning.

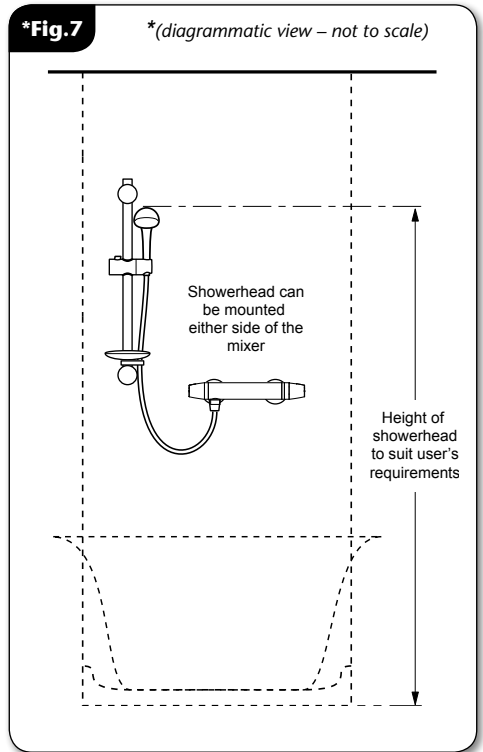
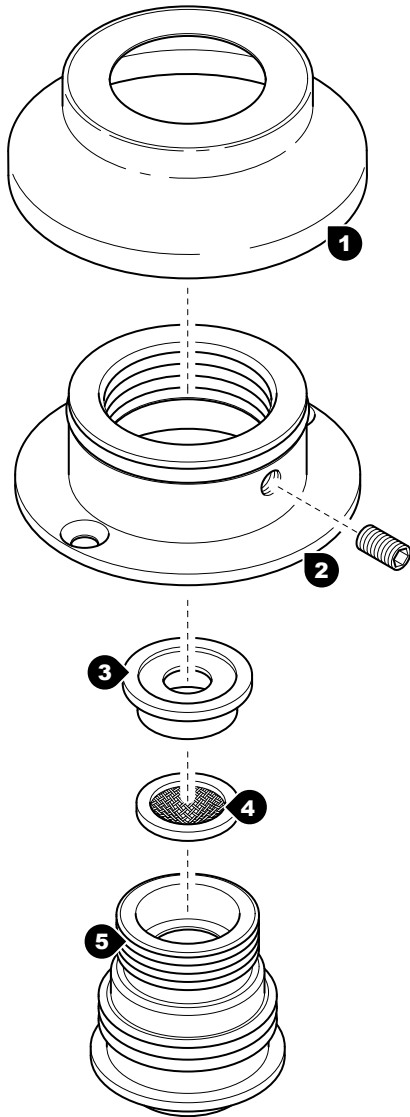

Fig.8



INTRODUCTION

This guide contains all the necessary fitting instructions for your (built-in pipework, push-fit connector) bar mixer bracket. The bracket has been designed to be surface mounted, using 15mm pipework and can be used with bar mixers or bath shower mixers with $\frac{3}{4}$ " BSP fixings.

Please read the instructions carefully.

Read through the whole of this guide before beginning installation.

The bracket installation must be carried out by a suitably competent person and in the sequence of the instruction book.

Care taken during the installation will provide trouble free operation from the bracket.

SAFETY WARNINGS

- a. Layout and sizing of pipework must be such that when other services are used, pressures at the mixer control inlets do not fall below the recommended minimum.
- b. **DO NOT choose a position where the mixer shower could become frozen.**
- c. **DO NOT connect to any form of tap or fitting not recommended by the manufacturer.**
- d. Conveniently situated service valves in each inlet supply must be fitted as an independent method of isolating the bracket should maintenance or servicing be necessary.

Refer to the mixer installation guide for further information.

Replacement parts can be ordered from Customer Service.

⚠ WARNING ⚠

The threads of number 5 (push-fit connector) are sharp. The use of gloves or a suitable rag is recommended when handling the item, to avoid being cut by the threads.

WARNING!

Check there are no hidden cables or pipes before drilling holes for wall plugs. Use great care when using power tools near water. The use of a residual current device (RCD) is recommended.

COMPONENTS

The bracket is supplied as shown in **(fig.8)** and comprises of the following:

1. Cover trim - x2
2. Mounting plate and grub screw - x2
3. Plastic seal - x2
4. Flow regulator - x2
5. Filter - x2
6. Push-fit connector - x2
7. Locking clip - x2

PRIMARY CONSIDERATIONS

Please consider the following points before beginning the installation:

- The brackets must be mounted onto a surface that is both solid and strong enough to support the final assembly of brackets and bar mixer.
- The push-fit connectors can be used with either 15mm copper or plastic pipework.

DO NOT use chrome plated pipework.

- When installed, the pipework should not be fixed within one metre of the bracket.
- When installed, the pipework must be backed by a solid structure. When fitting the push-fit connectors, the pipework will need to resist the applied force.
- Clearance should be provided behind the finished wall (*at the point at which the pipework exits the wall*) to allow the pipe to be moved in and out of the wall by a minimum distance of 4mm. **This distance should be a measure of total travel of the pipe between a solid structure and the rear of the finished wall.** (This clearance will allow the pipework to move when the mounting plate is assembled onto the push-fit connector, ensuring that the seal to the pipework remains undisturbed) **(fig.9).**

- The pipes that enter the brackets should be cut using a suitable pipe cutter and deburred.

DO NOT use a hacksaw or other cutting tool that may damage the outer surface of the pipework as this may prevent a good seal to the push-fit connector.

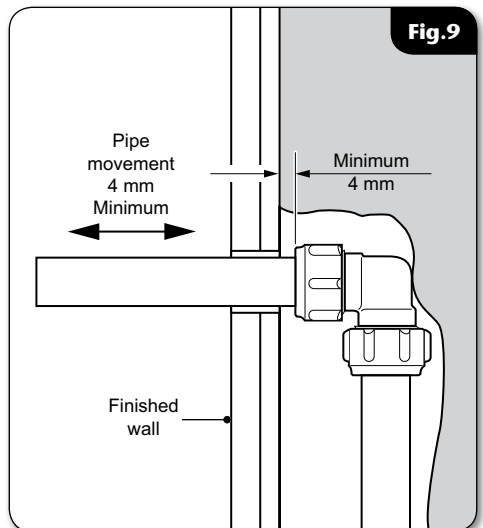
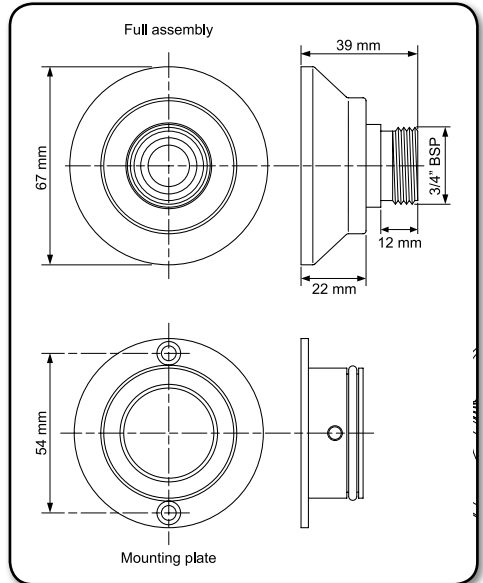
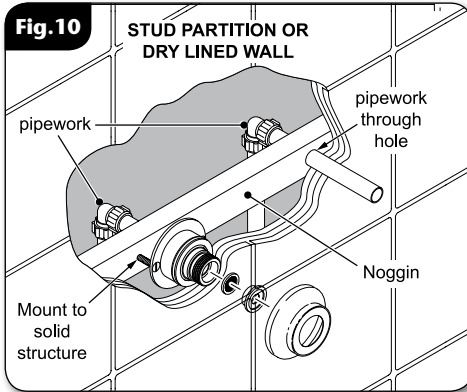

Fig.9



INSTALLATION

IMPORTANT: These bar mixer brackets are designed to be mounted onto a solid structure. If installing to a stud partition wall, dry lined wall or similar, it is recommended that the brackets are secured to the studs or noggins. In this case, the pipework to the brackets should pass through the support studs or noggins via a suitably sized hole (**fig.10**).

Decide upon the mounting position of the brackets on the wall and mark the centres. Check the mounting marks are level and that the distance between them is equal to the distance between the bar mixer inlet centres (**fig.11**). Mark the route of the pipework to the brackets. Remove the plaster and brickwork (or plasterboard) to the depth required and chase out additional areas of the wall to allow for the incoming pipework. Make sure that enough solid structure of wall remains around the chasing to accommodate the mounting plate wall plugs and screws (**fig.12**).

Complete the pipework to the bracket mounting points. Leave an excess of pipe protruding out of the wall of approximately 60mm as measured from the face of the finished wall or tiles (**fig.13**).

Flush the pipework through to remove any debris. Check for leaks and remedy as necessary.

Make good the wall and tiles. Make sure that the pipes exiting the wall are free and can move in and out of the wall by a minimum distance of 4mm (**fig.9**).

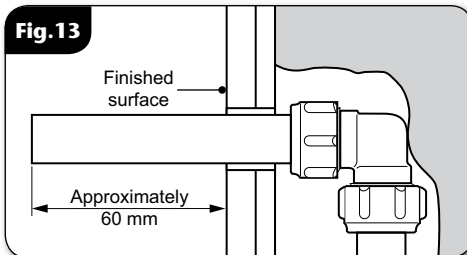
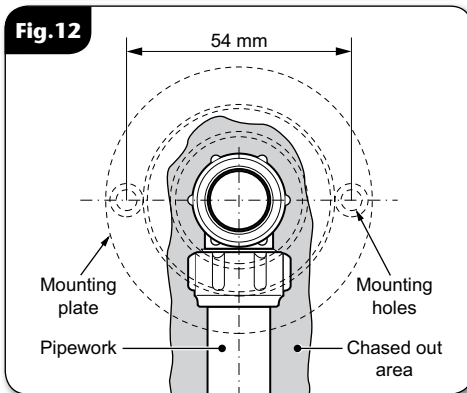
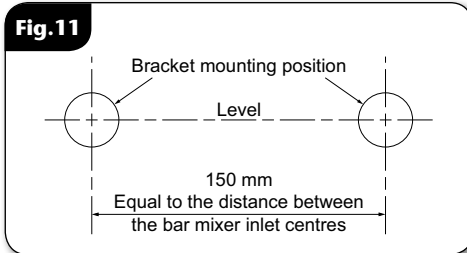

Push each pipe into the wall until it stops against the depth of chasing. Measure 29mm from the face of the finished wall or tiles and mark the pipe.

Using a pipe cutter, cut the pipe at the 29mm mark and deburr.

IMPORTANT: When the pipework is at rest against the depth of chasing the length of pipe protruding from the wall should be between 30mm MAXIMUM and 28mm MINIMUM from the face of the finished wall or tiles. (fig.14).

Make sure the outer surface of the pipes are clean and free of any debris or damage. Clean the surface if necessary.

IMPORTANT: Press a push-fit connector onto each pipe until the pipe is pushed passed the O'ring and reaches the stop within the connector. This can be visually checked by viewing the pipework through the push-fit connector outlet (fig.15). Insert locking clips onto hot and cold water push fit connections.

Fitting the mounting plate

Guarantee that the locking clips are in place before starting this procedure.

Screw the mounting plate onto the push-fit connector until it reaches the stop and begins to turn the connector itself (fig.15a).

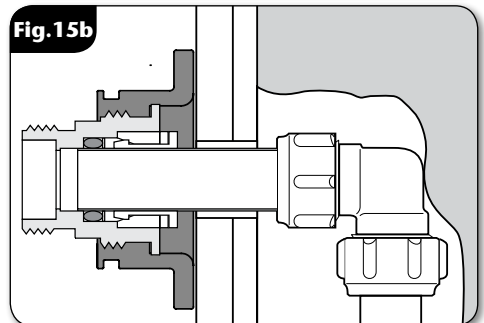
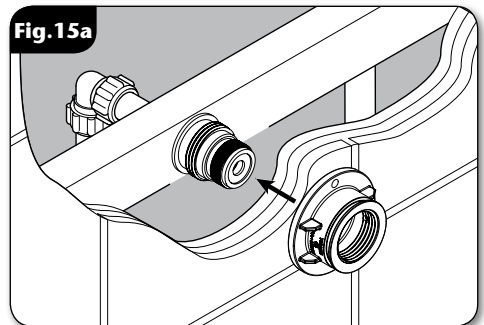
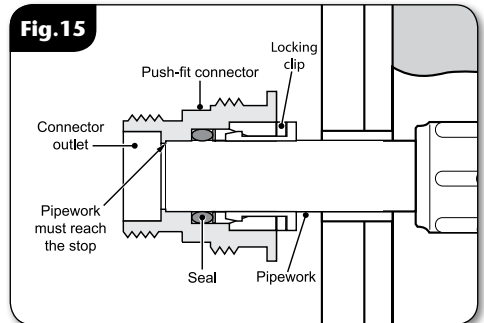
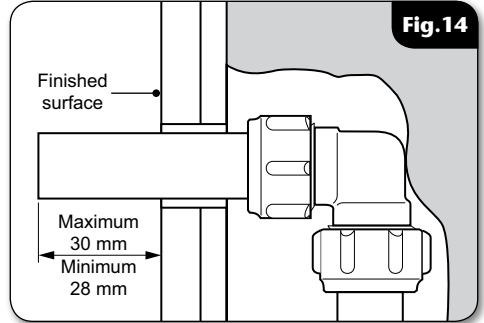
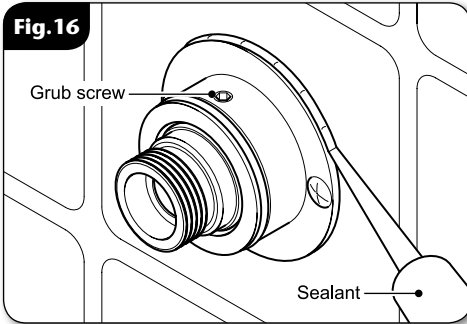

Fig. 16



Align the mounting plate fixing holes to the intended position and mark the holes. Remove the mounting plate. If necessary, hold the push-fit connector stationary when unscrewing the mounting plate. Drill and plug the wall. *(An appropriate drill bit should be used. If the wall is brick, plasterboard or a soft building block, appropriate wall plugs and screws should be fitted).*

Re-assemble the mounting plate onto the push-fit connector and secure the mounting plate to the wall.

Insert the grub screw into the mounting plate and tighten to secure the connector (**fig. 16**). Using a suitable sealant, seal the joint between the mounting plate and the wall or tiles to prevent water entering the wall. (**fig. 16**). Wipe away any excess sealant which may obstruct the fitting of the cover trim.

Push-fit the cover trims onto the mounting plates. A smear of liquid soap on the seal will ease this procedure (**fig. 17**).

Fit the seals into the push-fit connector outlets (**fig. 18**).

Fit and secure the bar mixer to the connectors.

Fig. 17

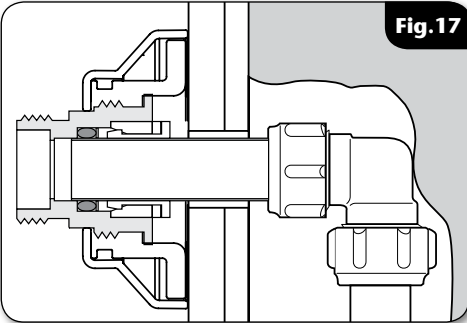
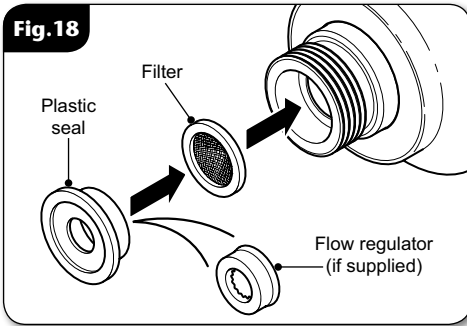

Fig. 18



COMMISSIONING

- Start the water flow by rotating the flow control (left hand side) anticlockwise.
- Make sure that the hot and cold water supplies are fully open and at (or near to) their design temperature and pressures, and are within the requirements as stated on **Page 2**.
- Make sure the temperature control (right hand side) is at the maximum temperature setting **WITHOUT** operating the maximum temperature override button.
- Allow the shower to run at this maximum temperature setting until the water temperature has stabilised.
- Rotate the temperature control until your desired 'maximum temperature stop' showering temperature is reached.

Note: *If your desired temperature is above the maximum temperature stop limit, please see 'ADJUSTING THE MAXIMUM TEMPERATURE STOP SETTING' on Page 14.*

- A final temperature check **SHOULD** be made on-site to guarantee user safety, and that the mixer falls within recommended 'maximum mixed water outlet temperatures' - **as stated on Page 14.**

FLOW REGULATION

A flow regulator is fitted for use with high-pressure water systems. It may be used with any of the systems listed to reduce flow rate and assist economy.

REMOVING THE FLOW REGULATOR

If installing the mixer to a water system with a **minimum head of 2 meters or below**, the flow regulator supplied **MUST** be removed.

Using a suitable tool carefully lever the flow regulator from outlet (**fig.19**).

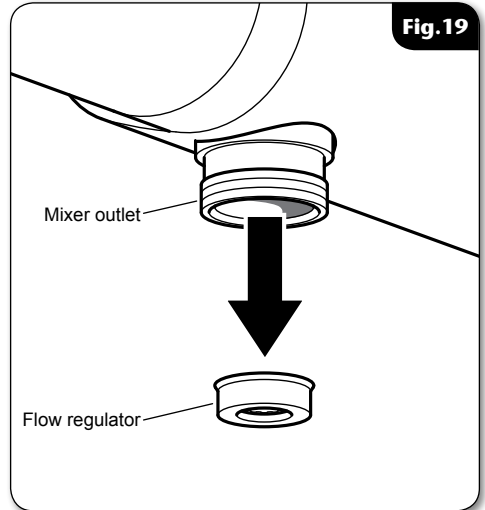

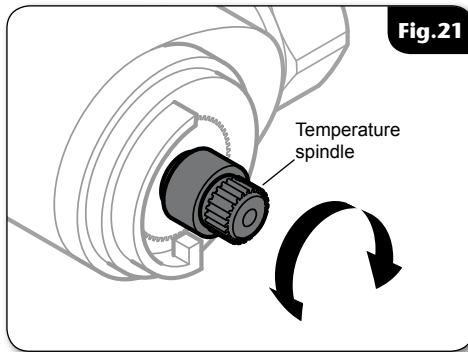
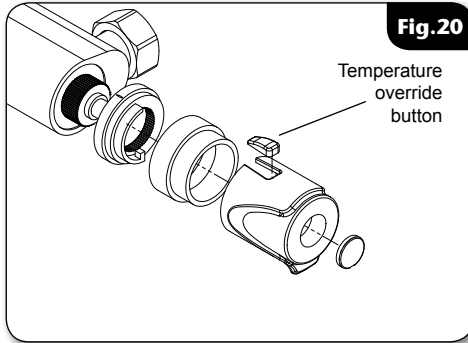

TEMPERATURE ADJUSTMENT RANGE

The mixer has a temperature stop to prevent accidental rotation to higher temperatures. This is adjustable to provide a maximum temperature of 35°C – 45°C.

The mixed water temperature can be adjusted from cold through to a top limit (which can be pre-set during installation – factory set at approximately 38°C) with full anti-scald protection throughout the range.

Recommended outlet temperatures

The **BuildCert TMV** scheme recommends the following set maximum mixed water outlet temperatures for use in all premises:

44°C - for bath fill but see notes below.

41°C - for showers.

41°C - for washbasins.

38°C - for bidets.

The mixed water temperatures must never exceed **46°C** at terminal fitting.

The British Burns Association recommends **37 to 37.5°C** as a comfortable bathing temperature for children. In premises covered by the Care Standards Act 2000, the maximum mixed water outlet temperature is **43°C**.

ADJUSTING THE MAXIMUM TEMPERATURE STOP SETTING

- Remove the end trim from the temperature control to allow access to the retaining screw. Undo the retaining screw and pull the temperature control off (**fig.20**).
- The maximum temperature stop does not need to be removed.
- Turn the flow control to full flow. With a steady flow running, adjust the temperature spindle until the temperature is about 38°C (**fig.21**).
- When the showering temperature is satisfactory turn off the shower. Refit the temperature control.
- Secure the temperature control in place with the screw and fit the trim.

OPERATING THE SHOWER

- To start the shower, rotate the flow control (left-hand side) anti-clockwise. For maximum flow, rotate the flow control anti-clockwise until it stops.

To stop the water flow, rotate the flow control clockwise until the water stops flowing (**fig.22**).

- To adjust the water temperature, rotate the temperature control (right-hand side), clockwise for a cooler shower, or anti-clockwise for a hotter shower (**fig.23**).
- To overcome the maximum temperature stop, depress the temperature override button (**fig.23**) on the temperature control and rotate clockwise past the '38°C' position.

CAUTION: *Exposed metal and chromed surfaces may become hot during use.*

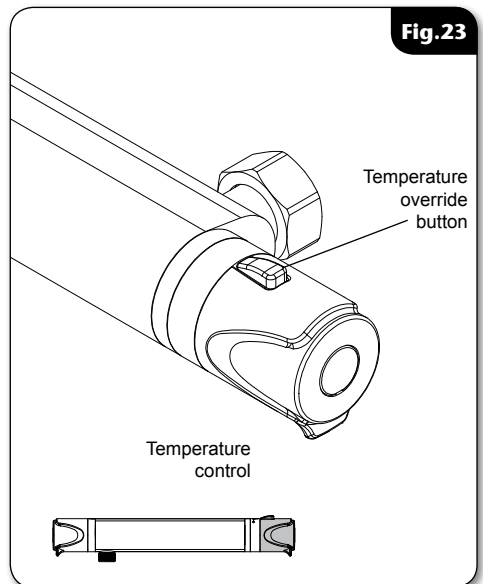
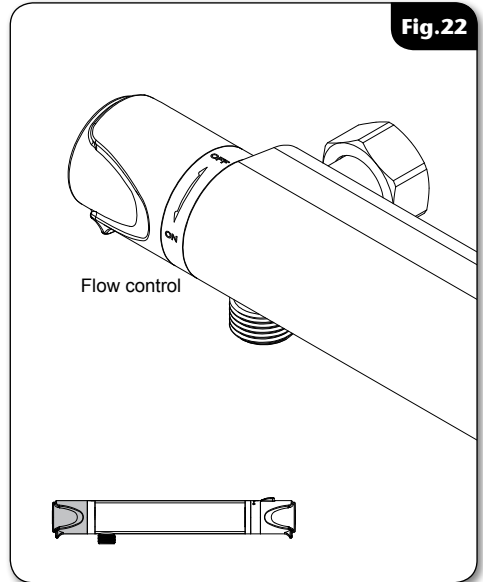

DIMENSIONS

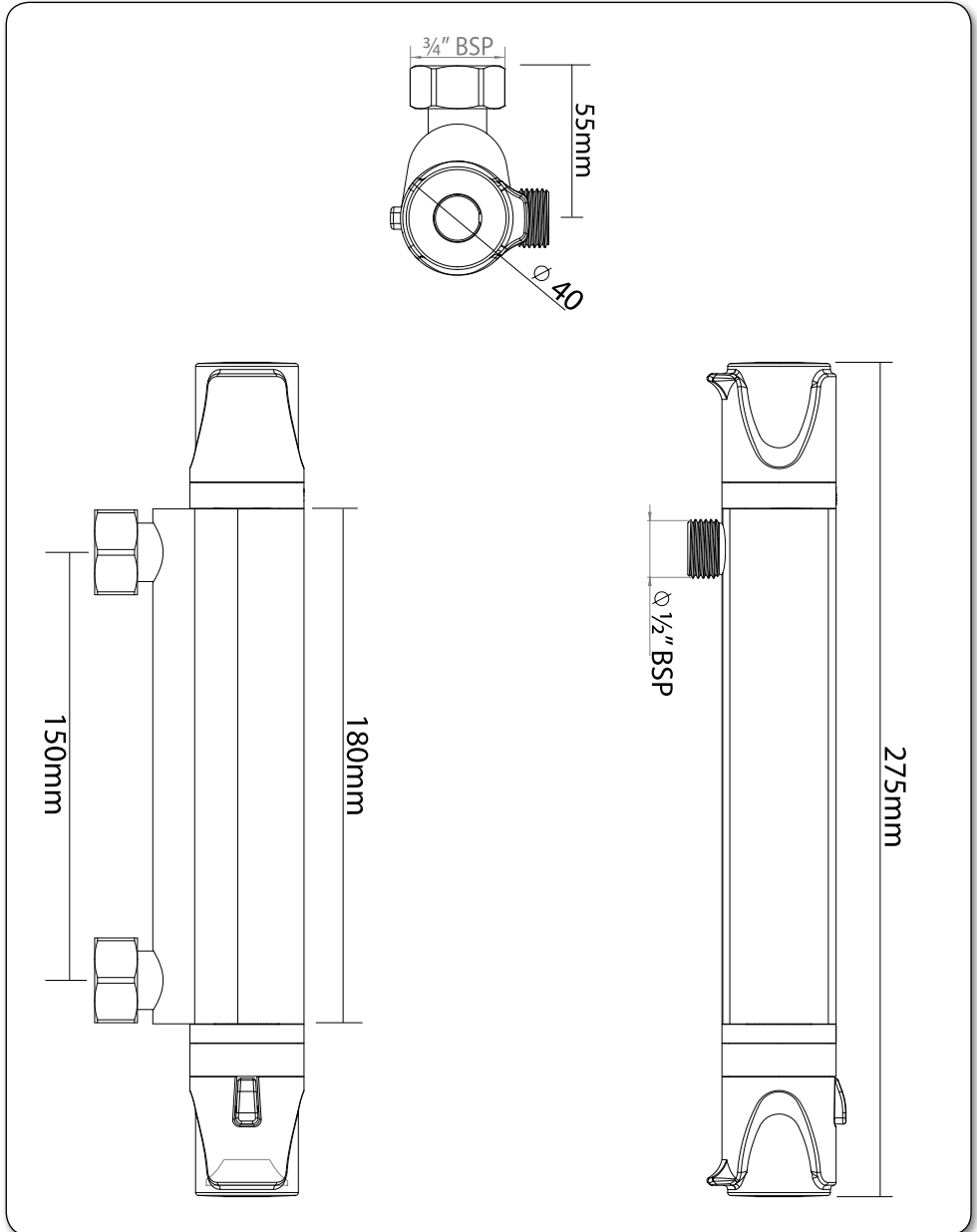

All dimensions listed in this fitting book regarding the product and installation are approximate.

SPARE PARTS

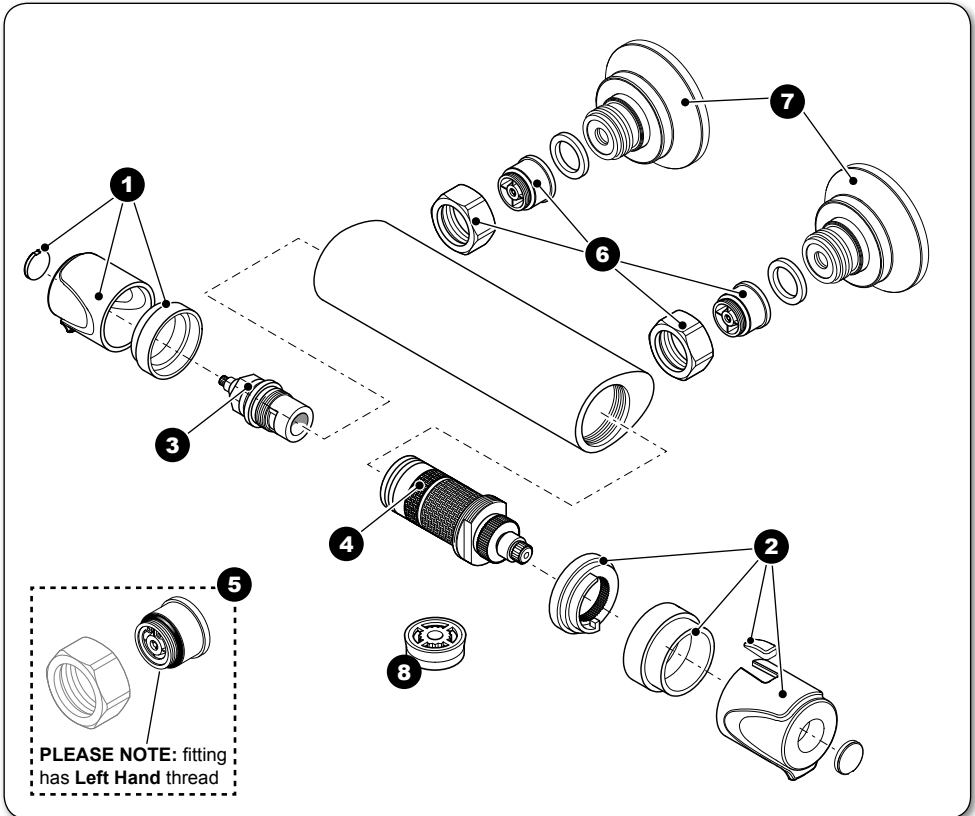

Ref. Description	Part No.	Ref. Description	Part No.
1. Flow knob	86004850	8. Flow regulators are available at the following ratings (6 L/M supplied): Flow regulator 3.0 L/M 22010310 Flow regulator 4.0 L/M 22011740 Flow regulator 5.0 L/M 22011750 Flow regulator 6.0 L/M 22011760 Flow regulator 7.0 L/M 22011610 Flow regulator 8.0 L/M 22011280 Flow regulator 12.0 L/M.....22013060	
2. Temperature knob.....	86004300		
3. Flow cartridge.....	83315530		
4. Thermostatic cartridge	83315540		
5. Trim pack.....	86001150		
6. Non return valve pack.....	83315550		
7. Bar bracket.....	86100057		

APPROVALS

This mixer valve is approved to the requirements of:

*On pressures above 0.5 bar.

Designation:

***BS EN 1111**

***WRAS**

HP-S (high pressure shower only)

TMV2 REQUIREMENTS (12 MONTHLY VERIFICATION)

It is a requirement that all TMV2 approved valves shall be verified against the original set temperature results once a year.

On installation and on a yearly basis please perform the following checks:

1. Cold water supply isolation test

Isolating the cold water supply to the TMV, wait for five seconds if water is still flowing check that the temperature is below **46C**.

If there is no significant change to the set outlet temperature ($\pm 2^{\circ}\text{C}$ or less change from the original settings) and the fail-safe shut off is functioning, then the valve is working correctly and no further service work is required.

If there is a residual flow during the commissioning or the annual check this is acceptable providing the temperature of the water seeping from the valve is no more than **2C** above the designated maximum mixed water outlet temperature setting of the valve.

Note:

Temperature readings should be taken at the normal flow rate after allowing for the system to stabilise.

The sensing part of the thermometer probe must be fully submerged in the water that is to be tested.

FLOW CHART

86004420 BAR VALVE XDL 5015 (NO KNOBS)

Flow Rate (l/m)	5.0	6.9	9.0	10.9	12.0	17.5	25.5	31.5	36.5	41.0
Pressure (bar)	0.1	0.2	0.3	0.4	0.5	1.0	2.0	3.0	4.0	5.0

Conditions for test

Inlet temperatures comply with EN1111 requirements

Outlet temperature 38°C

Flow Control Fully Open

Open Outlet - No hose or showerhead connected

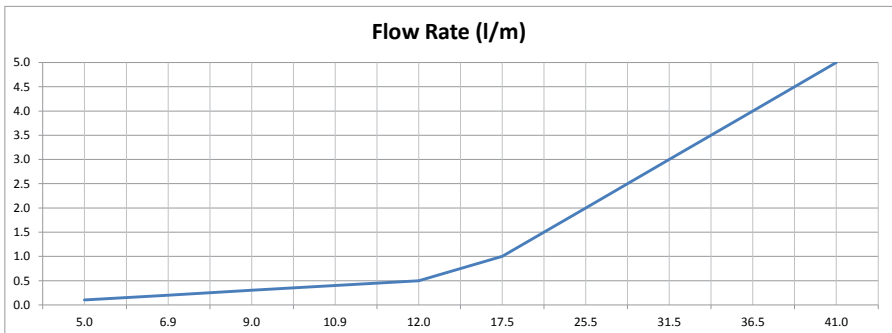

MAINTENANCE

The following maintenance procedure must be carried out for commercial and health care premises, but is not necessarily required for domestic installations.

Maintenance of the unit is required to give continued performance after installation and that it continues to provide scald prevention.

Note: *a thermostatic mixing valve in need of maintenance can be undetectable in normal use and only becomes apparent when a disruption occurs in the hot or cold water supply temperatures or pressures.*

It is a requirement that all TMV2 approved valves shall be verified against the original set temperature results once every 12 months.

- a) Initially check the filters for debris once every three months and clean if necessary.
- b) Perform a thermal shut off test every three months, and check the maximum temperature setting. See the 'Commissioning' section for the details of this test and readjustment of the maximum temperature setting if required.
- c) If the maximum water temperature varies by more than 2°C from the commissioned setting then carry out the following checks
 - Check the isolating valves are fully open.
 - Check the internal surface for scaling.

If the body requires descaling then it should be removed from the pipework to carry this work out (all rubber parts **MUST** be removed before descaling).

- Check the function of the non-return valves.

The non-return valves (NRVs) prevent cross-flow between hot and cold supplies under unequal pressure conditions. They are designed for long life with no maintenance.

Note: *the (NRV's) will only operate in one direction - water should be able to flow into the unit from the inlets, but NOT back out through the inlets.*

If these checks do not highlight the reason for the temperature variation, then internal components will require replacement - *please see the spare parts list.*

Cleaning

It is recommended that all products are cleaned using warm, soapy water.

Do not use abrasive or aggressive chemical cleaning products as this may affect the product surface finish and invalidate your guarantee.

Cleaning the filters (fig.A)

It is advised that this should be carried out by a qualified person.

- Turn off the water supplies before starting.
- To gain access to the filters remove the unit from the inlet fittings.
- Remove the filter housing and disassemble.
- Wash the filters thoroughly under running water, use a suitable brush to remove all debris.
- Reassemble and fit in reverse order.

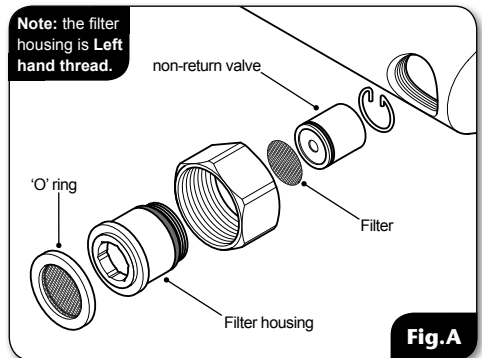

Disinfection

Where chlorine is used for the disinfection of water systems all relevant guidelines and approved codes of practice must be strictly followed. Failure to comply with the relevant guidelines and approved codes of practice may invalidate your guarantee.

WARNING!

DO NOT use 'powerful' abrasive or solvent cleaning fluids when cleaning the shower as they may damage the fittings.

FAULT FINDING

The following can be carried out by a competent person

Problem/Symptom	Cause	Action/Cure
1 Water too hot.	1.1 Temperature control incorrectly commissioned.	1.1.1 Refer to commissioning section.
	1.2 Not enough cold water flowing through shower.	1.2.1 Reposition temperature control knob
	1.3 Increase in the ambient cold water temperature.	1.3.1 Reposition temperature control knob.
	1.4 Cold water supply blocked.	1.4.1 Turn off the shower and consult a competent plumber or contact Customer Service.
	1.5 High volume of cold water drawn off elsewhere.	1.5.1 Reduce the simultaneous demand from the supply.
2 Water too cold.	2.1 Temperature control incorrectly commissioned.	2.1.1 Refer to 'commissioning' section.
	2.2 Not enough hot water flowing through shower.	2.2.1 Reposition temperature control knob
	2.3 Decrease in the ambient cold water temperature.	2.3.1 Reposition temperature control knob
	2.4 Insufficient hot water supplies from the heating system.	2.4.1 Make sure heating appliance is set to maximum or has sufficient stored hot water. 2.4.2 Make sure heating appliance is igniting by trying a hot water tap elsewhere.
	2.5 Hot water supply blocked or restricted.	2.5.1 Turn off shower and consult a competent plumber or contact Customer Service.
	2.6 Flow regulator not fitted (HP systems only).	2.6.1 Fit the supplied flow regulator (<i>Page 11</i>).
3 High water flow and/or poor performance on a mains fed system.	3.1 Flow regulators not fitted.	3.1.1 Fit flow regulator (<i>Page 11</i>).

FAULT FINDING

Problem/Symptom	Cause	Action/Cure
4 Water does not flow or shower pattern collapses when another outlet is turned on.	4.1 Water supplies cut off.	4.1.1 Check water elsewhere in house and if necessary contact local water company.
	4.2 Shower unit blocked.	4.2.1 Inspect the inlet filters. Clean if necessary.
	4.3 Blockage in pipework.	4.3.1 Turn off the shower and consult a suitably competent plumber.
	4.4 Showerhead blocked.	4.4.1 Clean showerhead.
	4.5 System not capable of supplying multiple outlets at the same time.	4.5.1 Reduce the simultaneous demand. 4.5.2 Make sure stop/service valves are fully open. 4.5.3 Check if sufficient water pressure.

The following is recommended for a professional qualified installer only

5 Water too cold.	5.1 Running pressure in excess of maximum recommended.	5.1.1 Fit a pressure reducing valve.
6 Shower controls noisy while in use.	6.1 Running pressure in excess of maximum recommended.	6.1.1 Fit a pressure reducing valve.
7 Shower will not shut off.	7.1 Flow control cartridge worn.	7.1.1 Renew flow control cartridge.

UK SERVICE POLICY

In the event of a product fault or complaint occurring, the following procedure should be followed:

1. Telephone Customer Service on **024 7637 2222** having available, your details including post code, the model number and power rating of the product, together with the date of purchase and, where applicable, details of the particular fault.
2. If required, the Customer Service Advisor will arrange for a qualified engineer to call.
3. All products attended to by a Triton service engineer must be installed in full accordance with the Triton installation guide applicable to the product. *(Every product pack contains an installation guide, however, they can also be downloaded free at www.tritonshowers.co.uk).*
4. Our engineer will require local parking and if a permit is required this must be available to the engineer on arrival at the call.
5. It is essential that you or an appointed representative (*who must be over 18 years of age*) is present for the duration of the service engineer's visit. If the product is in guarantee you must produce proof of purchase.
6. Where a call under the terms of guarantee has been booked and the failure is not product related (*i.e. scaling and furring, incorrect water pressure, pressure relief device operation or electrical/plumbing installation fault*) a charge will be made. A charge will also be issued if nobody is at home when the service engineer calls or adequate parking/permit is not available.
7. If the product is no longer covered by the guarantee an up front fixed fee will be charged before the site visit.
8. Should proof of purchase not be available on an "in-guarantee" call, or should the service engineer find that the product is no longer under guarantee, the engineer will charge the same fixed price and the customer will be expected to pay the engineer before he leaves. If payment is not made on the day an administration charge will be added to the fixed charge.
9. If a debt is outstanding from a previous visit, or from any other Triton purchase. Triton reserves the right to withhold service until the debt has been settled.
10. Triton takes the health, safety and wellbeing of its employees very seriously and expects customers to treat all staff members with respect. Should any employee feel threatened or receive abuse, either verbally or physically, Triton reserves the right to withhold service and will support the employee with a legal prosecution.

Replacement parts policy

1.1. It is the policy of Triton Showers to maintain parts availability for the duration of production and a period of 5 years thereafter in accordance with industry standards. Spare parts can be ordered via our online spare parts store, or by telephoning Triton Customer Service Spares Department on 024 7637 2222. Payment should be made by credit / debit card (excluding American Express or Diners Card). Payment can also be made by pre-payment of a pro-forma invoice, by cheque or postal order. **1.2. Telephone orders are based on information given during the call. Before contacting Triton, please verify your requirements using the information contained in the user guide. Triton cannot accept liability for incorrect part identification.**

TRITON STANDARD GUARANTEE

With the exception of accessories, Triton guarantee the product against all manufacturing defects for a period of **5 years** (for domestic use only) from the date of purchase, provided that it has been installed by a competent person in full accordance with the fitting instructions.

All accessories such as shower heads, hoses and riser rails carry a **1 year** parts only guarantee against manufacturing defects.

Any part found to be defective during this guarantee period we undertake to repair or replace at our option without charge so long as it has been properly maintained and operated in accordance with the operating instructions, and has not been subject to misuse or damage. This product must not be taken apart, modified or repaired except by a person authorised by Triton. This guarantee applies only to products installed within the United Kingdom and does not apply to products used commercially. This guarantee does not affect your statutory rights.

What is not covered:

1. Breakdown due to: **a)** use other than domestic use by you or your resident family; **b)** wilful act or neglect; **c)** any malfunction resulting from the incorrect use or quality of electricity, gas or water or incorrect setting of controls; **d)** failure to install in accordance with this installation guide
2. Claims for missing parts once the product has been installed.
3. Repair costs for damage caused by foreign objects or substances.
4. Total loss of the product due to non-availability of parts.
5. Compensation for loss of use of the product or consequential loss of any kind.
6. Call out charges where no fault has been found with the appliance.
7. The cost of repair or replacement of isolating switches, electrical cable, fuses and/or circuit breakers or any other accessories installed at the same time. Replacement of the Pressure Relief Device that only activates when the shower outlet is blocked, is also excluded.
8. The cost of routine maintenance, adjustments, overhaul modifications or loss or damage arising therefrom, including the cost of repairing damage, breakdown, malfunction caused by corrosion, furring,
9. Call out charges where the water supply cannot be isolated, this includes consequential losses arising from unserviceable supply valves.

For the latest Terms & Conditions, please see:
www.tritonshowers.co.uk

Triton Showers
Triton Road
Nuneaton
Warwickshire CV11 4NR

Triton is a division of Norcross Group (Holdings) Limited

Customer Service: 024 7637 2222
Trade Installer Hotline: 024 7637 8344
Fax: 024 7632 4504
www.tritonshowers.co.uk

E-mail: serviceenquiries@tritonshowers.co.uk
technical@tritonshowers.co.uk

LEWIS

Riser rail assembly

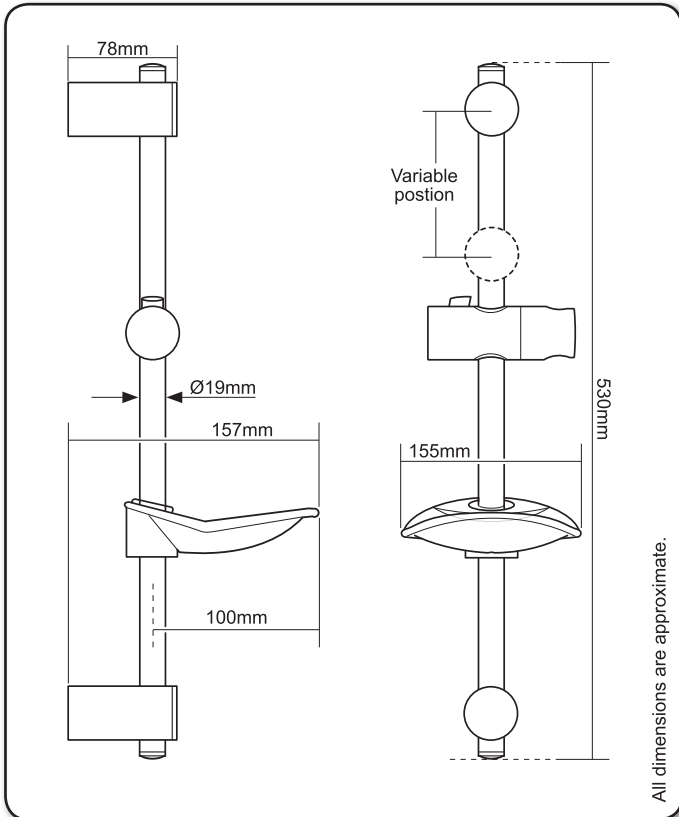

Installation Instructions

INSTALLERS PLEASE NOTE THESE INSTRUCTIONS ARE TO BE LEFT WITH THE USER

FITTING THE RISER RAIL ASSEMBLY

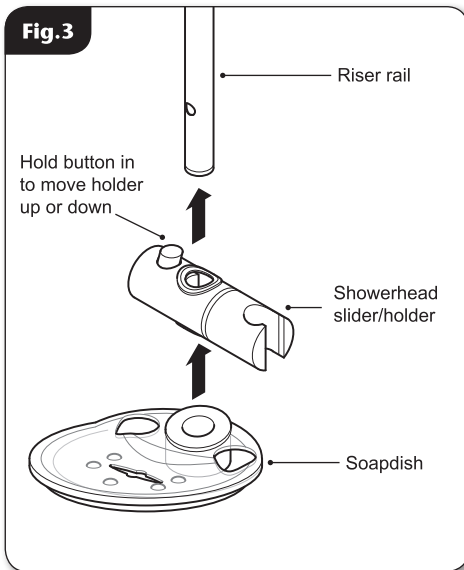
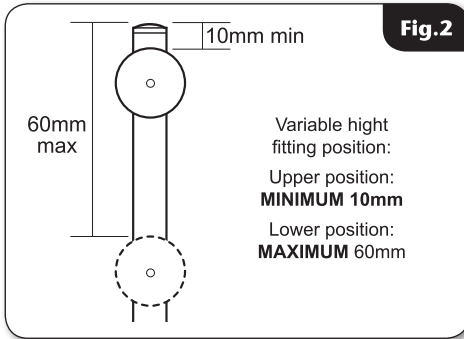
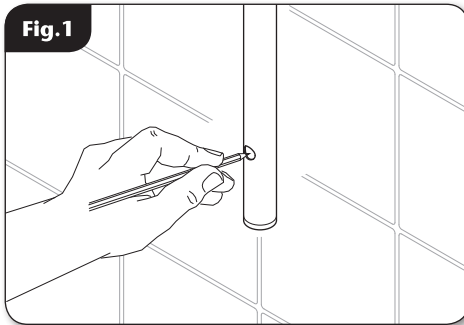

FITTING THE RISER RAIL

⚠ WARNING!

Check there are no hidden cables or pipes before drilling holes for wall plugs. Use great care when using power tools near water. The use of a residual current device (RCD) is recommended.

- Using the riser rail as a guide, decide the position of the top of the riser rail. Once determined, this will allow the bottom fixing bracket hole to be marked. The rail has two different size holes in it. The rail should be fitted with the larger hole facing out and at the bottom.
- Drill and plug the bottom hole. (*An appropriate drill bit should be used. If the wall is brick, plasterboard or a soft building block, appropriate wall plugs and screws should be fitted.*)
- Making sure that the riser is vertical and that the top of the fixing bracket will be **no closer than 10mm** to the top of the riser rail, mark the position of the top fixing hole. The bracket may be fitted at a variable height. It is advised that the bracket is **NOT** fitted more than **60mm** from top of the riser rail (**fig.2**).
- Once the upper bracket hole has been drilled and plugged, the bracket may be fitted as the retaining screw will sit in behind the riser rail.
- Before the riser rail and bottom bracket can be fitted and secured to the wall, the following items need to be fitted in the order and orientation shown in (**fig.3**) - the slider/holder can be fitted with the showerhead on either the left or right of the riser rail. The soapdish has two in built hose retaining rings for left or right hose fitting.

FITTING THE RISER RAIL ASSEMBLY

- Once all of the items are in place the riser rail can be inserted into the top and bottom brackets and the bottom bracket secured in place with the retaining screw (**fig.4**).
- Finally the top and bottom trims can be clicked into place.

Should the need arise, the trim cover can be removed by inserting a screwdriver and very carefully levering it away from the bracket.

FITTING THE HOSE AND SHOWERHEAD*

NOTE: The hose has two different ends. One end has two flats on it, this is the end that should be connected to the showerhead (**fig.5**).

- Feed the flexible hose through a hose retainer hole in the soapdish (The hose retainer **MUST** be used to comply with Water Regulations).

NOTE: The holder is slightly tapered and the showerhead and hose will only fit from the top.

IMPORTANT: It is the conical end of the hose which grips into the holder. The showerhead will not fit in the holder without the hose attached.

- Screw the flexible hose to the shower outlet and showerhead, making sure the supplied washers are in place and the correct ends are fitted to the shower and showerhead (**fig.5**).
- Place the showerhead into the holder and check that it fits correctly.

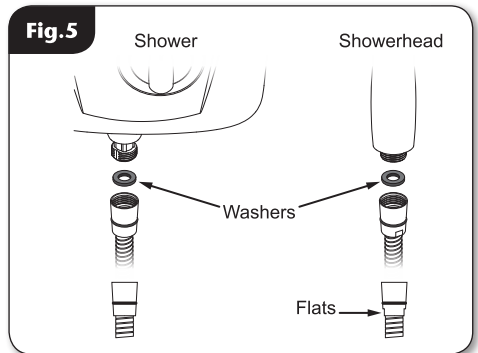
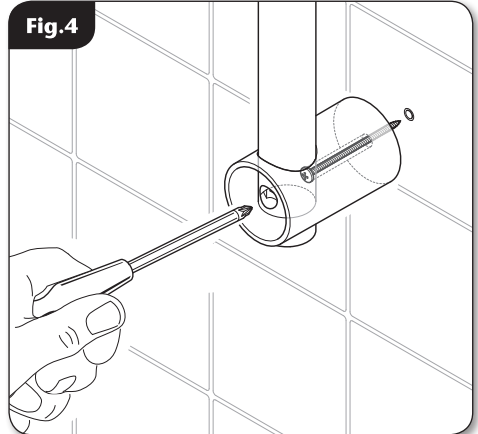

*Not supplied unless otherwise stated.

SPARE PARTS

<i>Ref. Description</i>	<i>Part Number</i>
-------------------------	--------------------

- | | |
|---------------------------------------|----------|
| - Kit without rail | |
| <i>white</i> | 88900033 |
| <i>chrome</i> | 88900034 |
| 1. Brackets & trims (pair) | |
| <i>white</i> | 83314660 |
| <i>chrome</i> | 83314670 |
| 2. Trim (single) | |
| <i>white</i> | 83314690 |
| <i>chrome</i> | 83314700 |
| 3. Riser rail 530mm | |
| <i>chrome</i> | 88800024 |
| 4. Showerhead holder/slider | |
| <i>white</i> | 83314710 |
| <i>chrome</i> | 83314720 |
| 5. Soap dish (clear) | 83314730 |

Flexible hoses available in the following sizes:

- 1.00m in white, chrome and gold
- 1.25m in white, chrome and gold
- 1.75m in chrome only

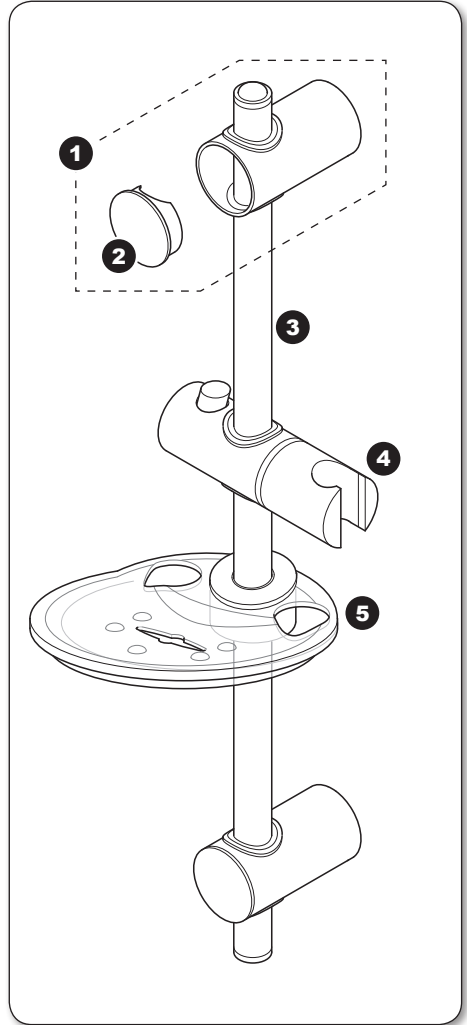

Please refer to shower installation and operating instructions for service details.

LARA

Three position shower head

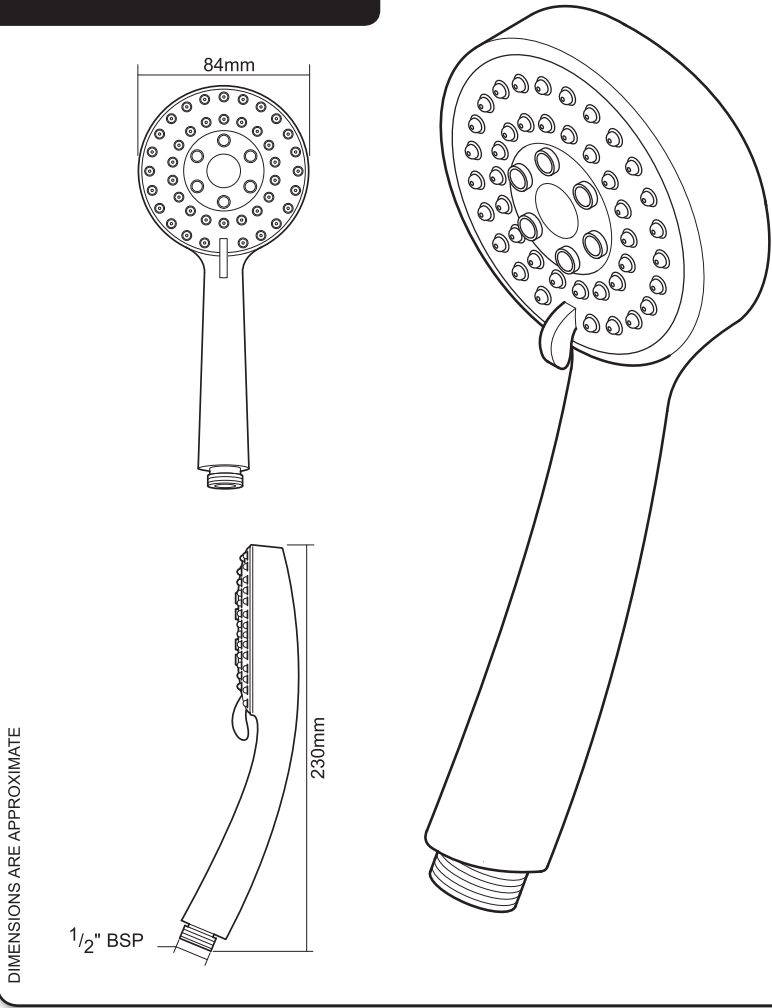

INSTALLERS PLEASE NOTE THESE INSTRUCTIONS ARE TO BE LEFT WITH THE USER

LARA three position shower head

Fig. 1

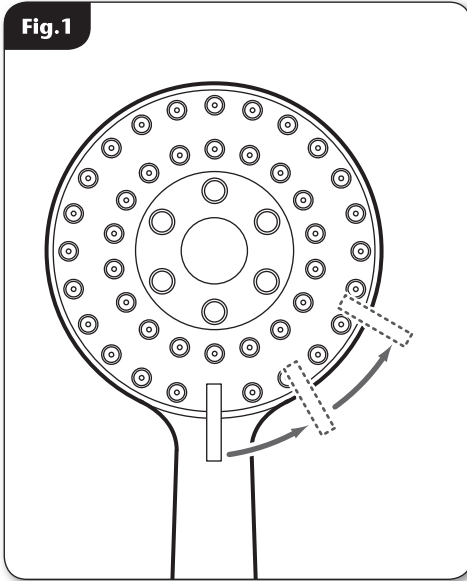

SPARES

Ref.	Description	Part No.
1.	Showerhead - chrome	88500040
2.	Showerhead - white	88500043

INSTALLATION

Before installing the shower head, flush the pipework through to remove any debris that may be in the system.

The showerhead has three spray positions. The position settings are shown in (fig.1).

CLEANING

Triton recommends that all products are cleaned using warm, soapy water.

Do not use abrasive or aggressive chemical cleaning products as this may affect the product surface and finish.

Note: The showerhead can be cleaned quickly by simply rubbing your fingers over the faceplate.

Before cleaning, turn off the unit at the mains supply to avoid the shower being accidentally switched on.

IT IS IMPORTANT TO KEEP THE SHOWERHEAD CLEAN TO MAINTAIN THE PERFORMANCE OF THE SHOWER. The hardness of the water will determine the frequency of cleaning. For example, if the shower is used every day in a very hard water area, it may be necessary to clean the showerhead on a weekly basis.

Note: The shower head is not designed to be disassembled.

