

CONOR

Riser rail assembly

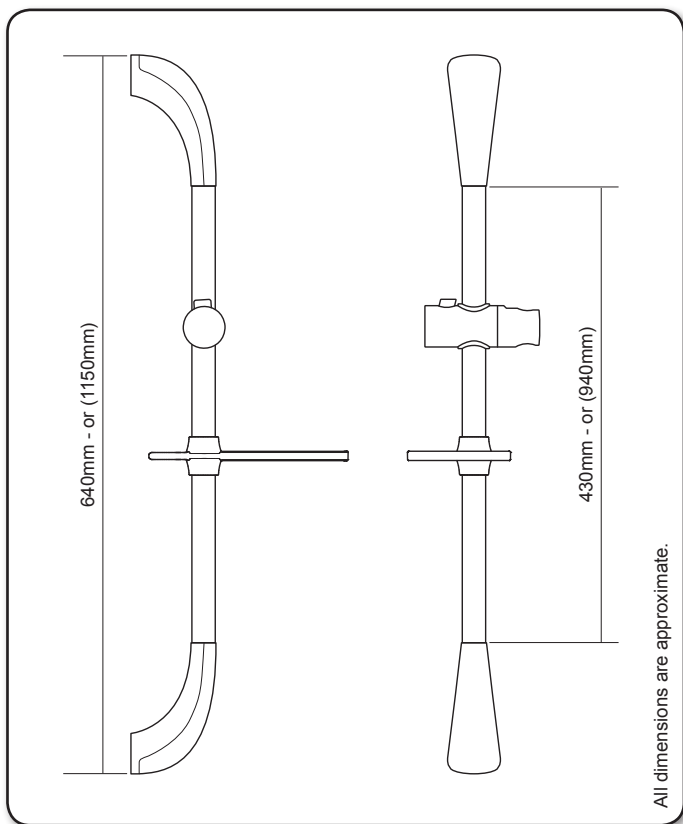

Installation Instructions

INSTALLERS PLEASE NOTE THESE INSTRUCTIONS ARE TO BE LEFT WITH THE USER

FITTING THE CONOR RISER RAIL ASSEMBLY

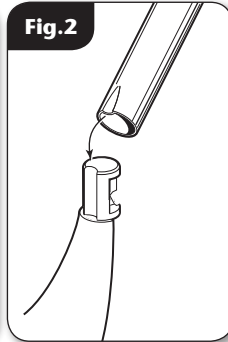
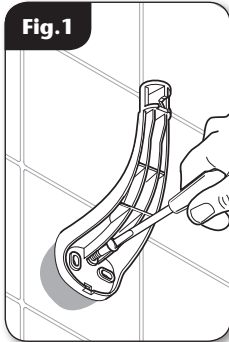

FITTING THE RISER RAIL

WARNING!

Check there are no hidden cables or pipes before drilling holes for wall plugs. Use great care when using power tools near water. The use of a residual current device (RCD) is recommended.

Decide on the position for the rail on the wall within the shower area. Proceed as follows:

- Offer one of the brackets to the wall for the lower position only. Note there are three holes in the brackets but two screws will usually be enough. Mark the centre hole and one of the other two.
- **Drill and plug the wall.** (An appropriate drill bit should be used. If the wall is brick, plasterboard or a soft building block, appropriate wall plugs and screws should be fitted).
- Replace the bracket to the wall and secure **(fig. 1)**.
- Locate the rail onto this lower bracket, making sure the rail engages fully on the bracket. Check that the indent in the riser rail engages into the cut-out on the bracket end **(fig. 2)**.
- Locate the second bracket on top of the rail. Check the rail is vertical then mark the centre hole and of the other two holes. Remove the bracket and rail. Drill and plug the wall.
- Fit the slider/holder assembly and the soap dish onto the riser rail. The slider can be fitted with the showerhead on either the left or right of the riser rail and the soap dish can be fitted either way up **(fig. 3)**.

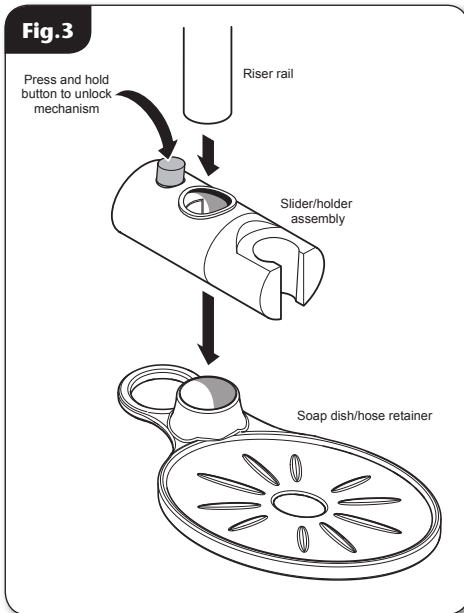

FITTING THE CONOR RISER RAIL ASSEMBLY

- Place the rail onto the installed lower bracket. Replace the upper bracket onto the rail and secure the rail to the wall with the screws supplied (**fig.4**).
- Place a trim cover onto each bracket. Make sure the large tab at the narrow end of the trim cover fits into the slot between the rail and bracket (**fig.5**) before pushing and clicking the other end into place.

Should the need arise, the trim covers can be removed by inserting a screwdriver into the slot and carefully levering off the trim.

FITTING THE HOSE AND SHOWERHEAD

- Feed the flexible hose through the appropriate soap dish opening (**fig.6**) so that the dish acts as a retaining ring (Water Regulations).

Note: *The holder is slightly tapered and the showerhead and hose will only fit from one direction.*

- Screw the flexible hose onto the shower outlet and showerhead (**fig.7**), making sure the supplied washers are in place at both ends of the flexible hose.
- Place the showerhead into the holder (**fig.8**) and check that it fits correctly.

IMPORTANT: This riser rail assembly is supplied with a hose retainer. Water Regulations require the fitting of a double check valve or similar device in the supply pipework to prevent backflow if the retainer is not used.

IMPORTANT: It is the conical end of the hose which grips into the holder. The showerhead will not fit in the holder without the hose attached.

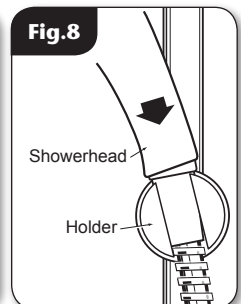
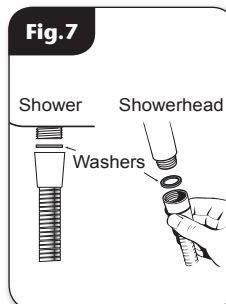
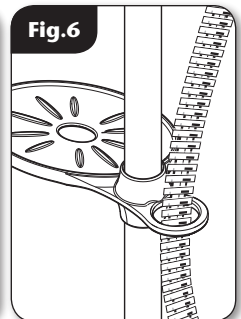
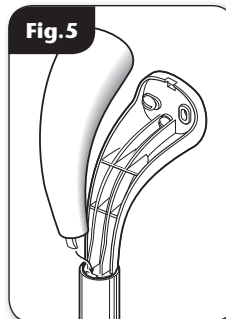
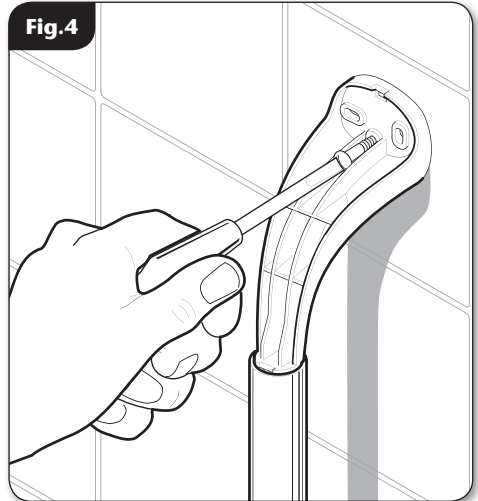

SPARE PARTS

Ref. Description	Part Number
- Kit without rail - <i>white</i>	88900020
- Kit without rail - <i>chrome</i>	88900028
1. Brackets (pair) - <i>white</i>	83306160
Brackets (pair) - <i>chrome</i>	83306170
2. Riser rail	
430 mm - <i>anodised</i>	7042409
430 mm - <i>white</i>	7042411
430 mm - <i>chrome</i>	7042412
940 mm - <i>anodised</i>	7042935
3. Showerhead holder - <i>white</i>	83313470
Showerhead holder - <i>chrome</i>	83314210
4. Soap dish - <i>white</i>	7054123
Soap dish - <i>clear</i>	7054124

Flexible hoses available in the following sizes:

- 1.00 m in white, chrome and gold
- 1.25 m in white, chrome and gold
- 1.75 m in chrome only

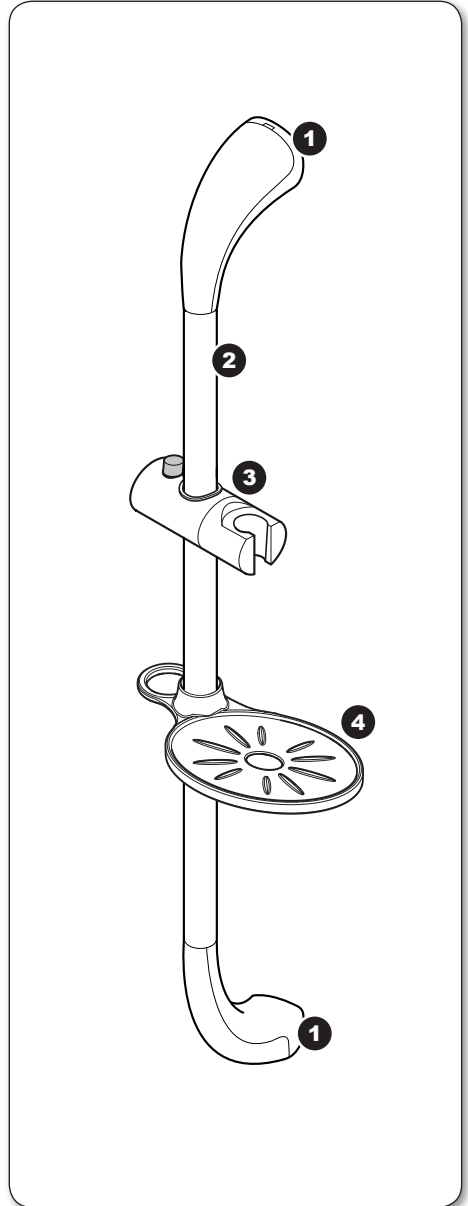

Please refer to shower installation and operating instructions for service details

LARA
Three position
shower head

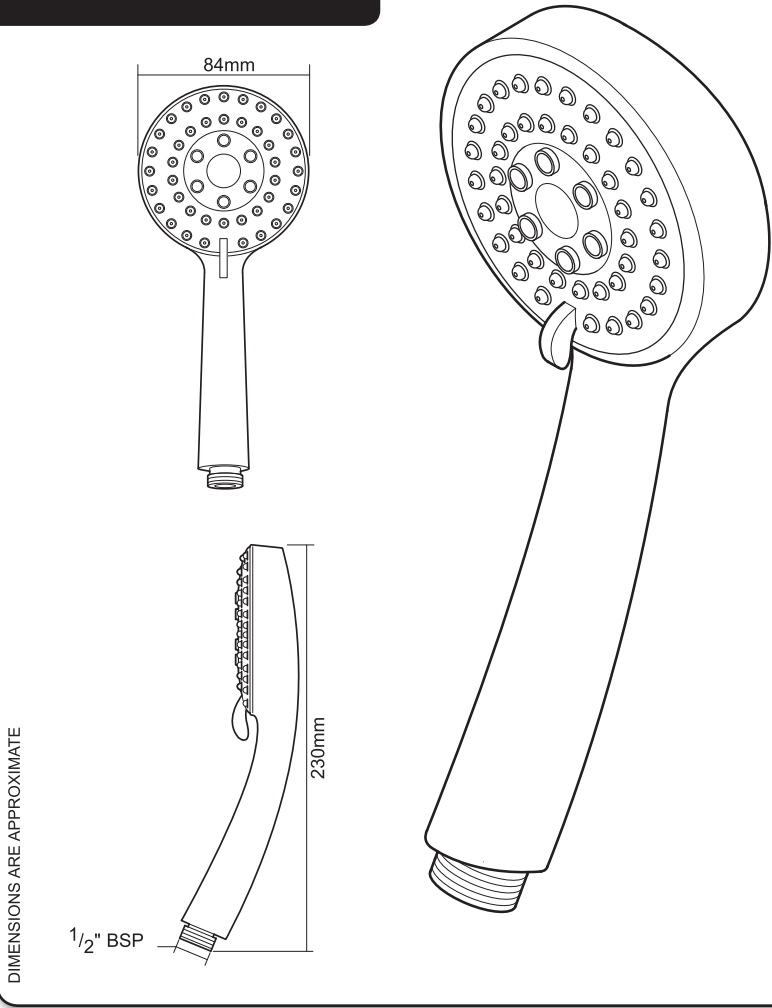

INSTALLERS PLEASE NOTE THESE INSTRUCTIONS ARE TO BE LEFT WITH THE USER

LARA three position shower head

Fig. 1

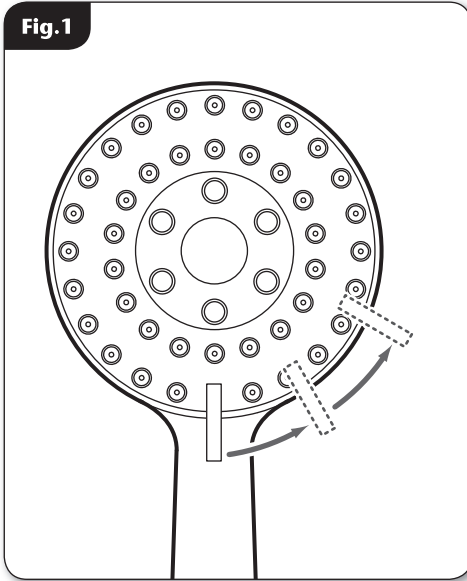

SPARES

Ref.	Description	Part No.
1.	Showerhead - chrome	88500040
2.	Showerhead - white	88500043

INSTALLATION

Before installing the shower head, flush the pipework through to remove any debris that may be in the system.

The showerhead has three spray positions. The position settings are shown in (fig.1).

CLEANING

Triton recommends that all products are cleaned using warm, soapy water.

Do not use abrasive or aggressive chemical cleaning products as this may affect the product surface and finish.

Note: The showerhead can be cleaned quickly by simply rubbing your fingers over the faceplate.

Before cleaning, turn off the unit at the mains supply to avoid the shower being accidentally switched on.

IT IS IMPORTANT TO KEEP THE SHOWERHEAD CLEAN TO MAINTAIN THE PERFORMANCE OF THE SHOWER. The hardness of the water will determine the frequency of cleaning. For example, if the shower is used every day in a very hard water area, it may be necessary to clean the showerhead on a weekly basis.

Note: The shower head is not designed to be disassembled.

