

ASPIRANTE

ASPIRANTE
*Wireless remote
electric shower*



**Installation and
Operating
Instructions**



INSTALLERS PLEASE NOTE THESE INSTRUCTIONS ARE TO LEFT WITH THE USER

CONTENTS	Page
Important safety information	1
Introduction	2
Specifications.....	2
Advice to users	3
Electrical requirements.....	4 – 5
Battery safety guidelines	6 – 7
Main components	8
Water requirements	9
Installation options	10 – 11
Siting of the shower	12 – 13
Installation.....	14
Fitting the remote pack	15 – 16
Plumbing connections	17 – 18
Fitting the bulkhead	19 – 20
Fitting the through ceiling water pipe	21
Fitting the PRD outlet tube.....	22
Electrical connections	23
Fitting the control panel bracket.....	24
Fitting the control panel.....	24
Fitting the remote pack cover.....	24
Associating the shower unit.....	25
Commissioning.....	26
Operating the shower	27 – 28
Operating functions	29 – 30
Continuous and timed operation.....	30
Battery life	30
Instructions for installers and service engineers only.....	31
Spare parts	32 – 33
Fault finding	34 – 35
Water/Cable entry points diagram	36
Guarantee, service policy, etc.	rear cover

To check the product suitability for commercial and multiple installations, please contact Triton's specification advisory service before installation.

Telephone: 0844 980 0730

Facsimile: 0844 980 0744

E mail: technical@tritonshowers.co.uk

PLEASE READ THIS IMPORTANT SAFETY INFORMATION

Products manufactured by Triton are safe and without risk provided they are installed, used and maintained in good working order in accordance with our instructions and recommendations.

- ⚠ WARNING: DO NOT** operate shower if frozen, or suspected of being frozen. It must thaw out before using.
- ⚠ DO NOT** operate the unit if the showerhead or spray hose becomes damaged.
- ⚠ DO NOT** restrict flow out of shower by placing showerhead in direct contact with your body.
- ⚠ DO NOT** operate the shower if water ceases to flow during use or if water has entered inside the unit because of an incorrectly fitted cover.
- ⚠ WARNING: If restarting the shower immediately after stopping, be aware that a slug of hot water will be expelled for the first few seconds.**

1 GENERAL

- 1.1** Isolate the electrical and water supplies before removing the cover.
- 1.2** Read all of these instructions and retain them for later use.
- 1.3 DO NOT** take risks with plumbing or electrical equipment.
- 1.4** Isolate electrical and water supplies before proceeding with the installation.
- 1.5** The unit must be mounted onto the finished wall surface (on top of the tiles). **DO NOT** tile up to or seal around **ANY PART** of the unit using silicone sealer after fixing to the wall. Special care must be taken **NOT TO BLOCK OR SEAL ANY PRD VENTS ON THE UNIT**.
- 1.6** Contact Customer Service (*see back page*), if any of the following occur:
 - a)** *If it is intended to operate the shower at pressures above the maximum or below the minimum stated.*
 - b)** *If the unit shows a distinct change in performance.*
 - c)** *If the shower is frozen.*
- 1.7** If it is intended to operate the shower in areas of hard water (above 200 ppm temporary hardness), a scale inhibitor may have to be fitted. For advice on the Scale Inhibitor, contact Customer Service.
- 1.8** The showerhead must be cleaned regularly with descalant to remove scale and debris, otherwise restrictions to the flow on the outlet of the unit will result in higher temperatures and could also cause the (PRD) Pressure Relief Device in the unit to operate.
- 1.9** This product is not suitable for mounting into steam rooms or steam cubicles.

2 PLUMBING

- 2.1** The plumbing installation must comply with Water Regulations, Building Regulations or any particular regulations as specified by Local Water Company or Water Undertakers and should be in accordance with BS 6700.

- 2.2** The supply pipe must be flushed to clear debris before connecting to the shower unit.
- 2.3 DO NOT** solder pipes or fittings within 300mm of the shower unit, as heat can transfer along the pipework and damage components.
- 2.4 DO NOT** fit any form of outlet flow control as the outlet acts as a vent for the heater can.
- 2.5 DO NOT** use excessive force when making connections to the flexible hose or showerhead, finger tight is sufficient.
- 2.6** All plumbing connections must be completed before making the electrical connections.

3 ELECTRICAL

- 3.1** The installation must comply with BS 7671 'Requirements for electrical installations' (IEE wiring regulations), building regulations or any particular regulations as specified by the local Electrical Supply Company.
- 3.2** This appliance **MUST** be earthed.
- 3.3** In accordance with 'The Plugs and Sockets etc. (Safety) Regulations 1994', this appliance is intended to be permanently connected to the fixed wiring of the electrical mains system.
- 3.4** Make sure all electrical connections are tight to prevent overheating.
- 3.5** A 30mA residual current device (RCD) **MUST** be installed in all UK electric and pumped shower circuits. This may be part of the consumer unit or a separate unit.
- 3.6** Switch off immediately at isolating switch if water ceases to flow during use.
- 3.7** Other electrical equipment i.e. extractor fans, pumps must not be connected to the circuits within the unit.
- 3.8** Switch off at isolating switch when not in use. This is a safety procedure recommended with all electrical appliances.
- 3.9** As with all electrical appliances it is recommended to have the shower and installation checked at least every two years by a competent electrician to ensure there is no deterioration due to age and usage.

INTRODUCTION

This book contains all the necessary fitting and operating instructions for your wireless remote electric shower – please read them carefully.

The shower installation must be carried out by a suitably qualified person and in the sequence of this instruction book.

Care taken during the installation will provide a long, trouble-free life from your shower.

SPECIFICATIONS

Electrical

Nominal power rating at 240V	Nominal power rating at 230V
9.5kW – (40A MCB rating)	8.7kW – (40A MCB rating)
10.5kW – (45A MCB rating)	9.6kW – (40A MCB rating)

Water

Inlet connection – 15 mm diameter.
 Outlet connection – ½" BSP male thread.

Entry Points (for remote pack)

Water – **Right:** bottom back, bottom.

Cable – **Right:** middle back, top.

Materials

Backplate, cover, controls, showerhead – ABS.
 Sprayplate – Acetal.
 Elements – Minerally insulated corrosion resistant metal sheathing.

Dimensions (in mm)

	control panel	remote pack
Height	235	338
Width	180	208
Depth	40	98

Standards and Approvals

Splashproof rating IPX4.

Complies with the requirements of current British and European safety standards for household and similar electrical appliances.

Complies with requirements of the British Electrotechnical Approvals Board (BEAB).

Meets with Compliance with European New Approach Directives (CE).

Complies with the requirements of the Radio and Telecommunications Terminal Equipment (RTTE) Directive 1999/5/EC.

Replacement parts can be ordered from Triton Customer Service. See 'spare parts' for details.

ADVICE TO USERS

The following points will help you understand how the shower operates:

- a. The electric heating elements operate at a constant rate at your chosen power setting. It is the rate of the water passing through the heater unit which determines the shower temperature at a given setting. (The slower the flow the hotter the water becomes, and the faster the flow the cooler the water.)
- b. During the winter the cold water supply will be cooler than in the summer months. Therefore, the temperature of the water will vary from season to season on any one setting of the control buttons, e.g. if you have chosen 'Economy' power for your preferred shower temperature in the summer, you will have to select the 'High' setting and adjust the temperature control during the winter months.
- c. The stabiliser valve minimises variations in shower temperature during mains water pressure changes. If changes in shower temperature are experienced during normal use, it will most likely be caused by the water pressure falling near to or below the minimum level. The drop in pressure may be due to water being drawn off at other points in the house while the shower is in use. If pressure drops appreciably below the minimum, the heating elements will automatically cut out.

If ever the water becomes too hot and you cannot obtain cooler water, first check the showerhead has not become blocked.

ELECTROMAGNETIC COMPATIBILITY

This product is intended for domestic use.

This product may temporarily be affected by electromagnetic disturbance near to the installation that could cause temporary operation of the low pressure indicator together with switching to the cold power selection. If problems persist, contact Triton Customer Service (see rear page).

IMPORTANT

When first installed (or following replacement of the PRD), the unit will be empty. It is essential the heater assembly contains water before the elements are switched on. As this unit has electronic control, it is vital that the commissioning procedure is followed. Failure to carry out this operation will result in damage to the unit and will invalidate the guarantee.

ELECTRICAL REQUIREMENTS

WARNING!

THIS APPLIANCE MUST BE EARTHED

The installation, supply cable and circuit protection must conform with BS 7671 (IEE wiring regulations) and be sufficient for the amperage required.

The following notes are for guidance only:

- 1** The shower must only be connected to a 230-240V ac supply. If you are installing a shower with a kilowatt rating above 9kW, it is advisable to contact the local electricity supply company.
- 1.1** The electrical rating of the shower is shown on the rating label (**Fig.3**) within the unit.

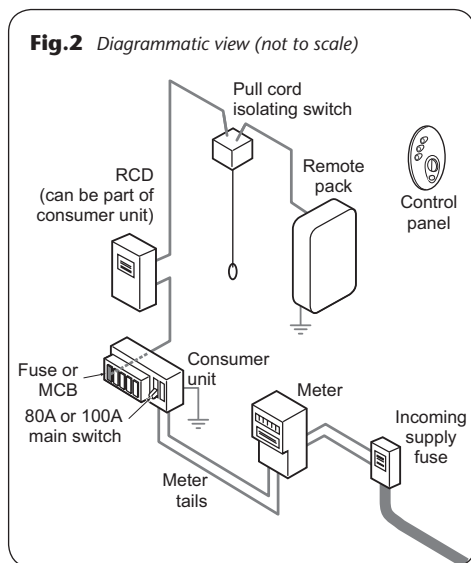
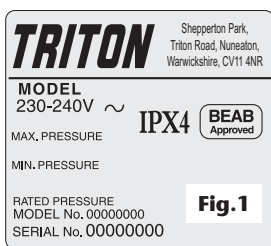

- 2** Before making any sort of electrical connection within the installation make sure that no terminal is live. If in any doubt, switch off the whole installation at the mains supply and remove the correct fuse.
- 3** The shower must be connected to its own independent electrical circuit. IT MUST NOT be connected to a ring main, spur, socket outlet, lighting circuit or cooker circuit.
- 3.1** The electrical supply must be adequate for the loading of the unit and existing circuits.
- 4** Check your consumer unit (main fuse box) has a main switch rating of 80A or above and that it has a spare fuse way which will take the fuse or Miniature Circuit Breaker (MCB) necessary for the shower (**Fig.4**).
- 4.1** If your consumer unit has a rating below 80A or if there is no spare fuse way, then the installation will not be straightforward and may require a new consumer unit serving the house or just the shower.
- 4.2** You will need to contact the local electricity company. They will check the supply and carry out what is necessary.
- 5** For close circuit protection DO NOT use a rewirable fuse. Instead use a suitably rated Miniature Circuit Breaker (MCB) or cartridge fuse (**see Table A**).

Table A

CIRCUIT PROTECTION

unit rating	MCB	cartridge fuse
7.0kW	30/32A	30A
7.5kW	32A	35A
8.0kW	40A	35A
8.5kW	40A	40A
9.0kW	40A	40A
9.5kW	40/45A	45A
10.5kW	45A	45A

- 5.1** A 30mA residual current device (RCD) must be installed in all UK electric and pumped shower circuits. This may be part of the consumer unit or a separate unit.
- 6** A 45 amp double pole isolating switch with a minimum contact gap of 3 mm in both poles must be incorporated in the circuit.
- 6.1** It must have a mechanical indicator showing when the switch is in the OFF position, and the wiring must be connected to the switch without the use of a plug or socket outlet.
- 6.2** The switch must be accessible and clearly identifiable, but out of reach of a person using a fixed bath or shower, except for the cord of a cord operated switch, and should be placed so that it is not possible to touch the switch body while standing in a bath or shower cubicle. It should be readily accessible to switch off after using the shower.
- 7** Where shower cubicles are located in any rooms other than bathrooms, all socket outlets in those rooms must be protected by a 30mA RCD.
- 8** The current carrying capacity of the cable must be at least that of the shower circuit protection (**see Table B**).
- 8.1** To obtain full advantage of the power provided by the shower, use the shortest cable route possible from the consumer unit to the shower.
- 8.2** It is also necessary to satisfy the disconnection time and thermal constraints which means that for any given combination of current demand, voltage drop and cable size, there is a maximum permissible circuit length.
- 9** The shower circuit should be separated from other circuits by at least twice the diameter of the cable or conduit.
- 9.1** The current rating will be reduced if the cabling is bunched with others, surrounded by thermal loft or wall insulation or placed in areas where the ambient temperature is above 30°C. Under these conditions, derating factors apply and it is necessary to select a larger cable size.
- 9.2** In the majority of installations, the cable will unavoidably be placed in one or more of the above conditions. This being so, it is strongly recommended to use a minimum of 10mm cabling throughout the shower installation.
- 9.3** In any event, it is essential that individual site conditions are assessed by a competent electrician in order to determine the correct cable size and permissible circuit length.

Table B

Twin and earth PVC insulated cable		
CURRENT CARRYING CAPACITY		
installed in an insulated wall	in conduit trunking	clipped direct or buried in a non-insulated wall
6 mm ²	6 mm ²	6 mm ²
32A	38A	46A
10 mm ²	10 mm ²	10 mm ²
43A	52A	63A
16 mm ²	16 mm ²	16 mm ²
57A	69A	85A

Note: Cable selection is dependent on derating factors

BATTERY SAFETY GUIDELINES

Used correctly, domestic batteries are a safe and dependable source of portable power. Problems can occur if they are misused or abused – resulting in leakage or, in extreme cases, fire or explosion.

Here are some simple guidelines to safe battery use designed to eliminate any such problems.

ALWAYS

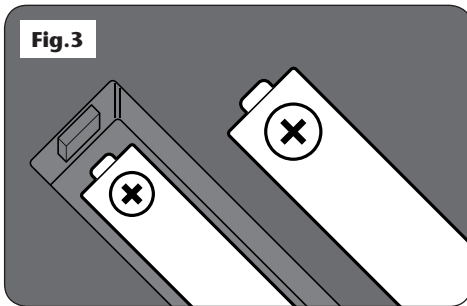

Take care to fit your batteries correctly, observing the plus and minus marks on the battery and appliance.

ALWAYS

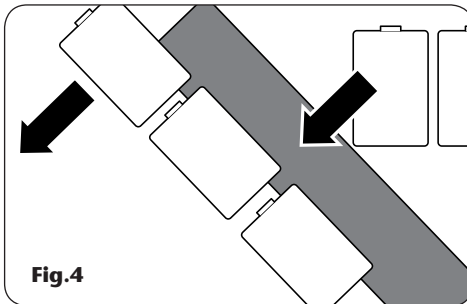

Replace the whole set of batteries at one time, taking care not to mix old and new batteries or batteries of different types.

ALWAYS

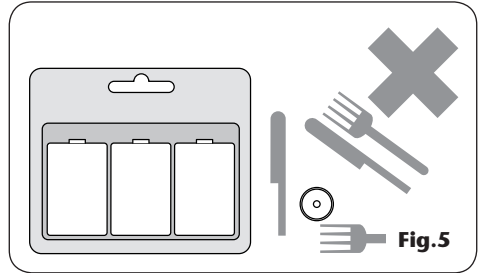

Store unused batteries in their packaging and away from metal objects which may cause a short-circuit.

ALWAYS

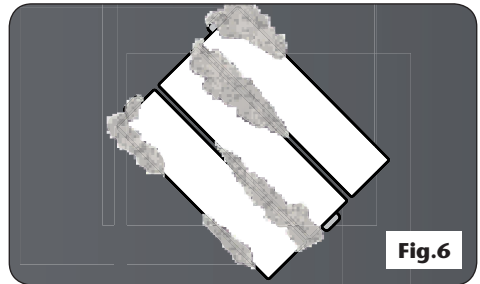

Remove dead batteries from equipment and all batteries from equipment you know you are not going to use for a long time. Otherwise the batteries may leak and cause damage.

NEVER

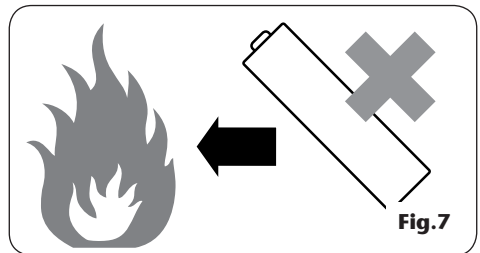

Never dispose of batteries in fire as this may cause them to explode.

NEVER

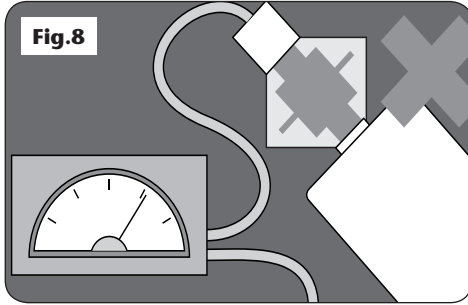

Never attempt to recharge ordinary batteries, either in a charger or by applying heat to them. There are special rechargeable batteries which are marked as such.

ALWAYS

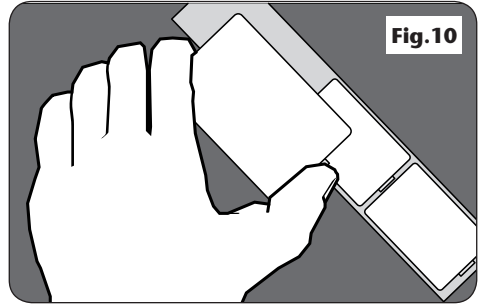

Supervise children if they are replacing batteries themselves in order to ensure these guidelines are followed.

ALWAYS

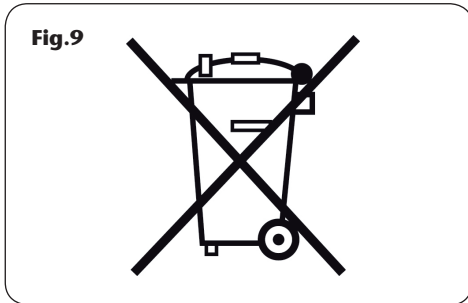

Always dispose of batteries in an environmentally friendly manner and in accordance with local regulations.

ALWAYS

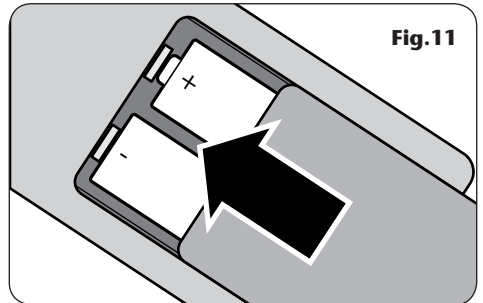

Make sure battery compartments are secure.

Fig.12

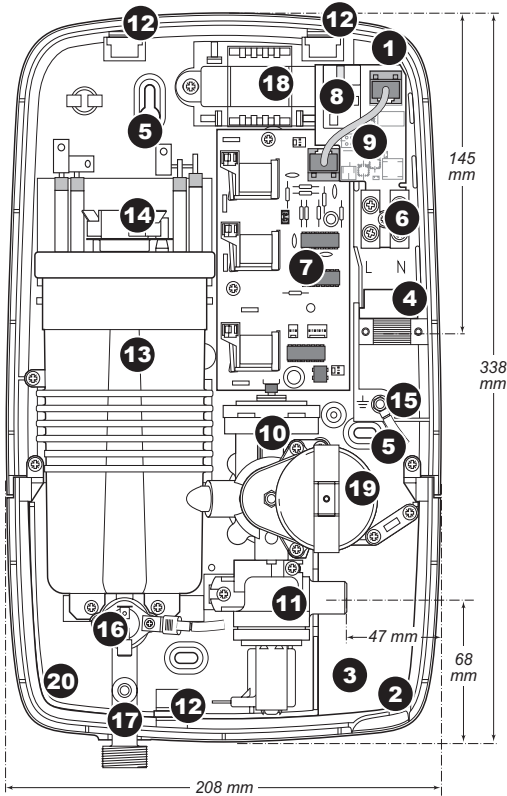

NOTE: Not all wiring shown for reasons of clarity

MAIN COMPONENTS

Remote pack (Fig.12)

1. Top cable entry
2. Bottom pipe entry
3. Rear pipe entry area
4. Rear cable entry area
5. Wall screw fixing
6. Terminal block
7. Printed circuit board
8. RF module
9. RF data cable
10. Stabilising valve
11. Solenoid valve
12. Guide pockets
13. Can and element assembly
14. Thermal safety cut-out (main)
15. Earth connection
16. Thermal cut-out (outlet)
17. Outlet pipe
18. Transformer
19. Stepper motor
20. Trimplate

Control panel (Fig.13)

21. Control panel

Pack contents

- Control panel
- Remote pack
- Bulkhead
- 2 m heated water tube extension (white)
- 3.5 m heated water tube (white)
- 10 mm push-fit elbow
- PRD tube (clear)
- Flexible hose
- Plumbing connection kit

Fig.13

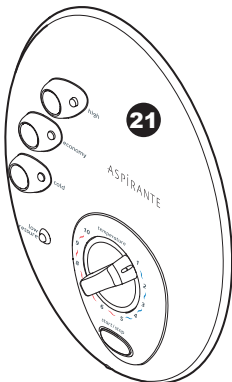

WATER REQUIREMENTS

The installation must be in accordance with Water Regulations/Bylaws. To ensure activation of the heating elements, the shower must be connected to a mains water supply with a minimum running pressure of 100 kPa (1.0 bar) at a minimum flow rate of nine litres per minute.

For the 10.5kW rated shower, the minimum running pressure must be 150 kPa (1.5 bar) at a minimum flow rate of eleven litres per minute.

For all units the maximum static pressure must be 1000 kPa (10 bar).

If in any doubt, the pressure should be checked.

Note: If the stated flow rate is not available, it may not be possible to achieve optimum performance from the unit throughout the year.

The water supply can be taken from a cold water storage cistern provided there is a minimum head of ten metres (fifteen metres for the 10.5kW model). Minimum head is the vertical distance from the base of the cistern to the showerhead. It must be an independent supply to the shower only.

If it is intended to operate the shower at pressures above the maximum or below the minimum stated, contact Customer Service for advice.

Fig. 14 shows a typical system layout for bulkhead and riser rail arrangement.

Fig. 15 shows a typical system layout for the through riser rail arrangement.

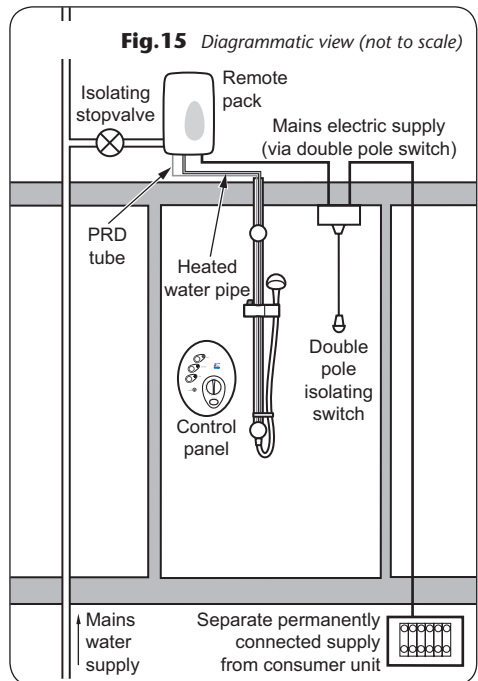
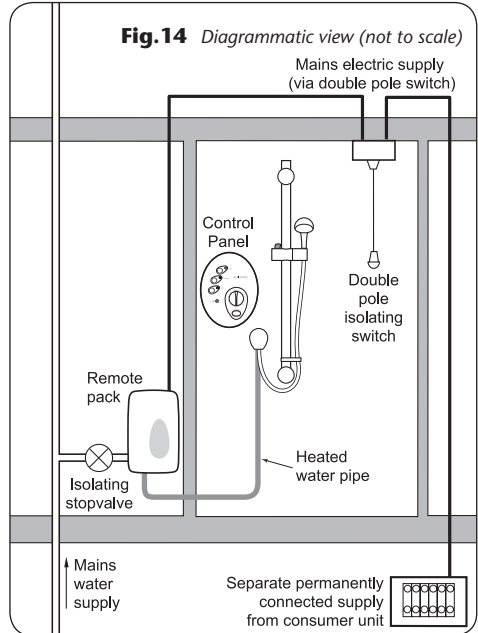
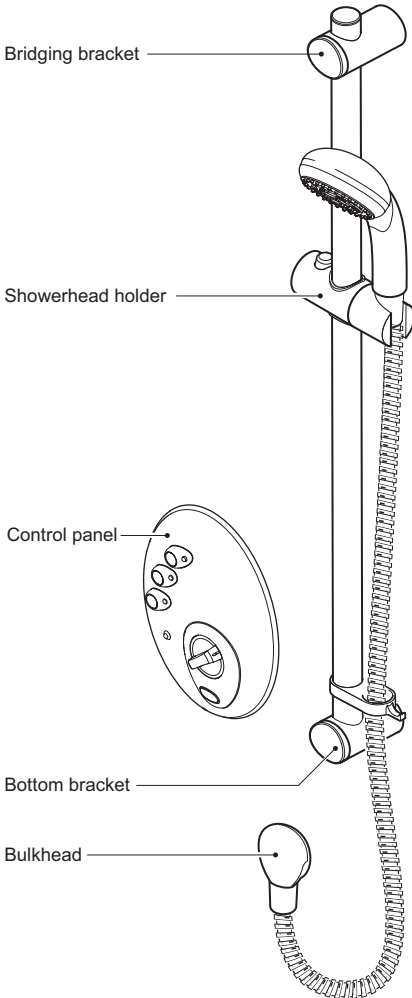

Fig.16 Bulkhead fitting



INSTALLATION OPTIONS

Bulkhead fitting

The control panel is installed onto a tiled wall. The remote pack is behind an adjoining wall with heated water pipe running to bulkhead (**Fig.16**). Stand-alone riser rail assembly.

Through the ceiling fitting

This option uses the Aspirante Zeus through the ceiling riser rail kit. Here the remote pack is installed in the loft with the heated water pipe and the PRD tube running down the inside of the riser rail. Water outlet at the bottom of the riser rail. **Fig.17** shows the short version using two brackets, while **Fig.18** shows the longer rail option using all three brackets.

Fig.17 Through the ceiling fitting (short)

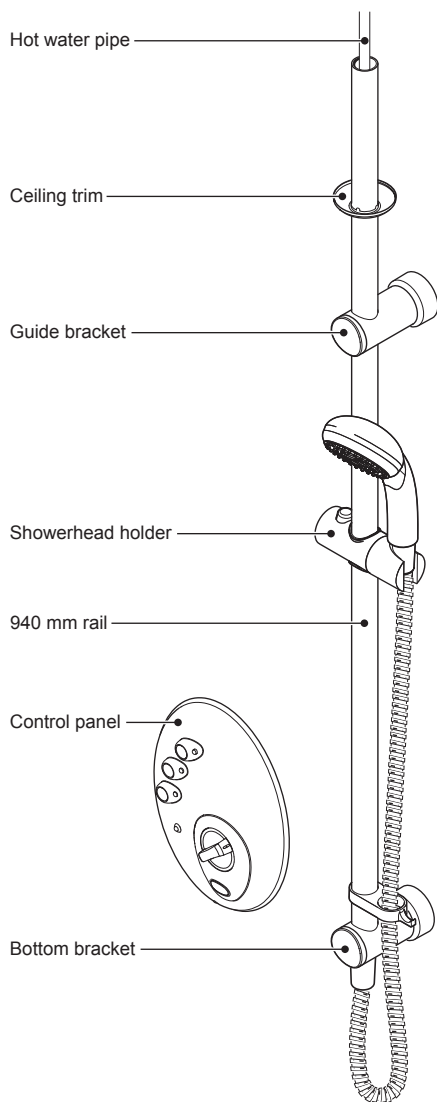

Fig.18 Through the ceiling fitting (long)

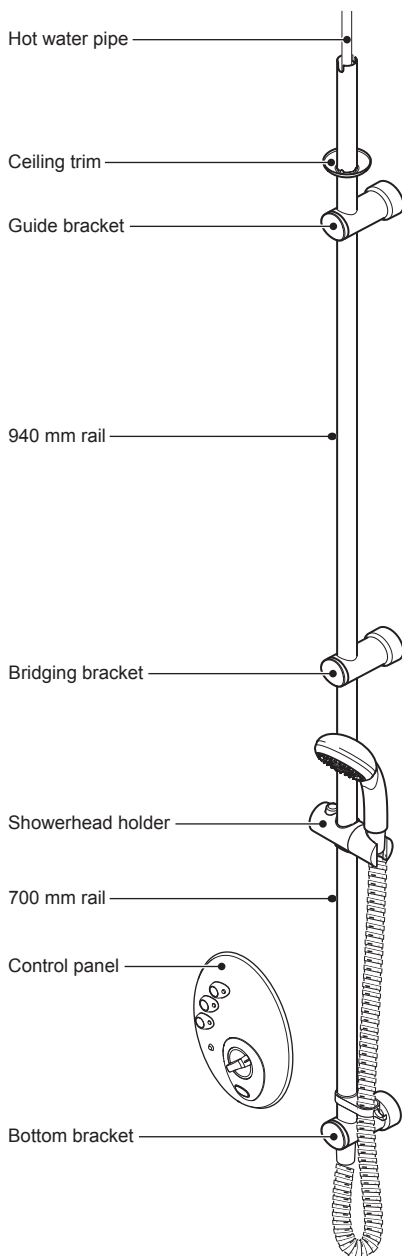
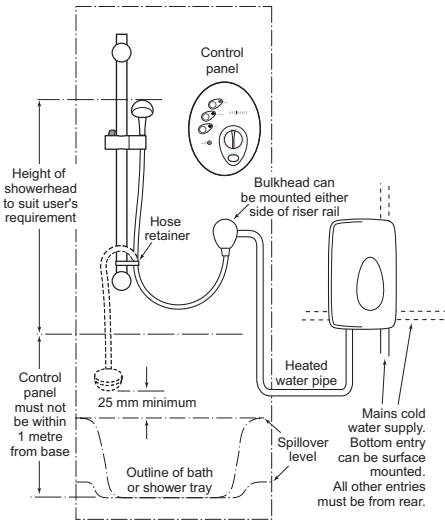

Fig.19



SITING OF THE SHOWER

WARNING!

The shower must not be positioned where it will be subjected to freezing conditions.

IMPORTANT: If installing onto a tiled wall always mount the unit on the surface of the tiles. NEVER tile up to the unit.

Refer to **Fig.19** and **Fig.20** for correct siting of the shower.

Position the control panel where it will NOT be in direct contact with water from the showerhead. Position the remote pack vertically and is accessible for maintenance purposes.

Note: Water Regulations requires that the showerhead be 'constrained by a fixed or sliding attachment so that it can only discharge water at a point not less than 25 mm above the spill-over level of the relevant bath, shower tray or other fixed appliance'. The use of the supplied hose retainer will usually meet this requirement, but if the showerhead can be placed within a bath, basin or shower tray, then a double check valve, or a similar device, must be fitted in the supply pipework to prevent back-flow.

Fig.20

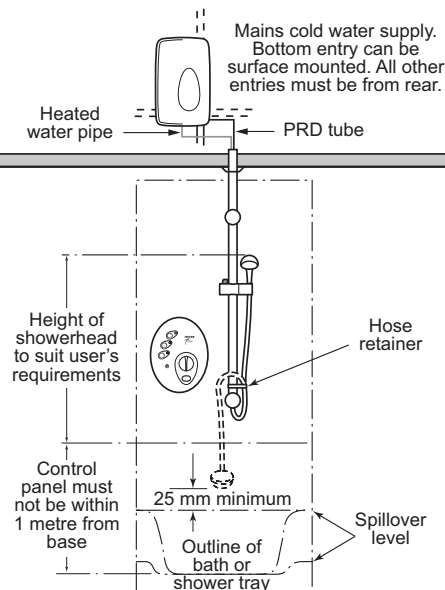

Pressure relief safety device

A pressure relief device (PRD) is designed into the shower unit which complies with European standards. The PRD (**Fig.21**) provides a level of appliance protection should an excessive build up of pressure occur within the shower.

IMPORTANT: If the PRD operates, then water will eject from the clear PRD tube.

If the shower installation option chosen uses the bulkhead fitting, make sure the PRD tube, when eventually installed, is routed carefully to waste e.g. via a tundish and pipework directed to an external point (**fig.22**).

If the shower installation option chosen is a through the ceiling fitting, then the PRD tube will follow the heated water pipe along the inside of the riser rail and terminate at the base of the riser rail (**fig.20**).

In the event of the PRD operating, turn off the electricity and water supplies to the shower at the isolating switch and stopvalve. Contact Customer Service for advice on replacing the PRD.

DO NOT operate the shower with a damaged or kinked shower hose, or a blocked showerhead which can cause the PRD to operate.

When commissioning, the showerhead must be removed from the flexible hose. If not removed, again it may cause the PRD to operate.

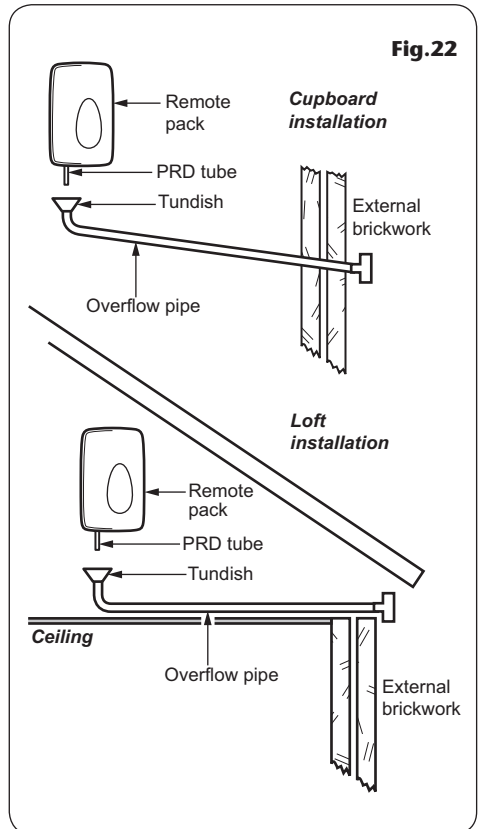
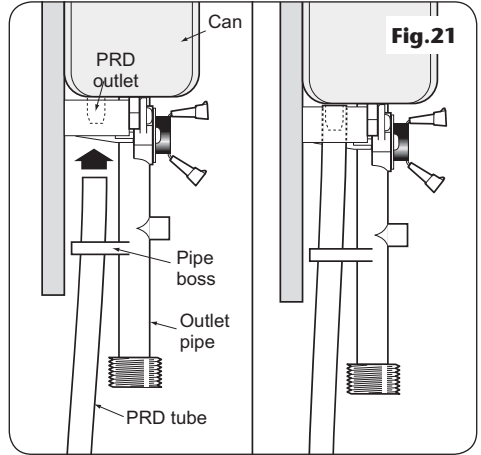

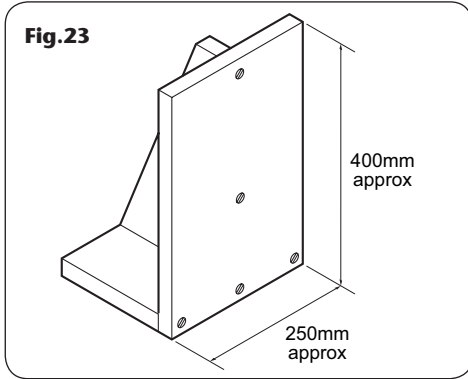

INSTALLATION

Heated water pipe in the wall

Decide on the position of the control panel, the bulkhead fitting and riser rail within the showering area. Establish a route in the wall between the remote pack and the heated water pipe.

IMPORTANT: If installing the remote pack in a loft space or similar with the through ceiling riser rail kit please refer to the riser rail fitting instructions for installation details.

The remote pack is connected to the bulkhead by means of a semi-rigid white 10 mm plastic pipe which carries the heated water. This pipe can be channelled in a wall, plumbed through a wall or hidden behind a studded wall. The pipe can run up to 3.5 metres away from the remote pack. Any surplus pipe can be cut off as required.

Note: The bulkhead and control panel may be placed on different walls as long as the control panel is not in line with any spray when in use.

Routing the heated water pipe

After deciding the position of the riser rail and control panel, you may wish first to channel a route for the semi-rigid heated water pipe from the remote pack location to the bulkhead position.

Make good the wall, including any tiling, as all the units must be screwed to the finished wall surface.

FITTING THE REMOTE PACK

IMPORTANT: The remote pack must be mounted on a flat surface which covers the full width and length of the backplate. It is important that the wall surface is flat otherwise difficulty may be encountered when fitting the cover and subsequent operation of the unit may be impaired.

The remote pack must always be positioned so that there is easy access for installation and maintenance. Where this is difficult or a suitable wall is not available, a mounting bracket similar to that shown in **Fig.23** can be used.

Position the remote pack in a dry, well ventilated area.

IMPORTANT: The remote pack **MUST** be mounted vertically. **DO NOT MOUNT IT HORIZONTALLY.**

If the remote pack is installed in a loft area the following requirements must be met for future servicing purposes:

- a. There must be no risk of the remote pack, heated water pipe or PRD tube becoming frozen.
- b. The remote pack must not be covered with any form of insulating material that may give rise to electrical circuits overheating during periods of high ambient temperature.
- c. A safe means of access must be provided into the loft, e.g. via a fixed loft ladder.
- d. The remote pack must be installed upright and in an accessible and safe location.
- e. Ceiling joists must be adequately boarded to provide safe and unobstructed access to, from and around the remote pack.
- f. There must be adequate lighting in the loft for servicing purposes.

Procedure

Unscrew the top and bottom retaining screws (**Fig.24**) and lift cover from the backplate. To allow access to the pipe and cable connections, remove the two screws (**Fig.25**) and take off the trimplate.

WARNING!
The remote pack must not be positioned where it will be subjected to freezing conditions.

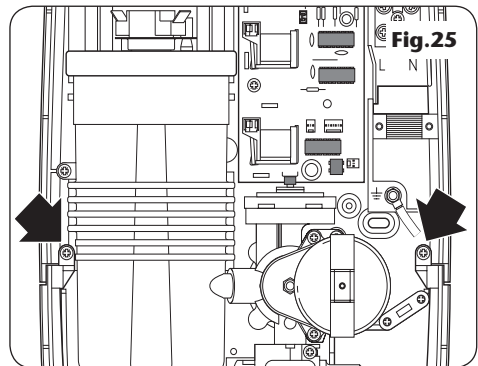
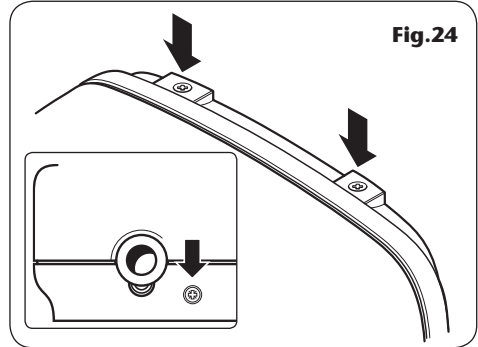
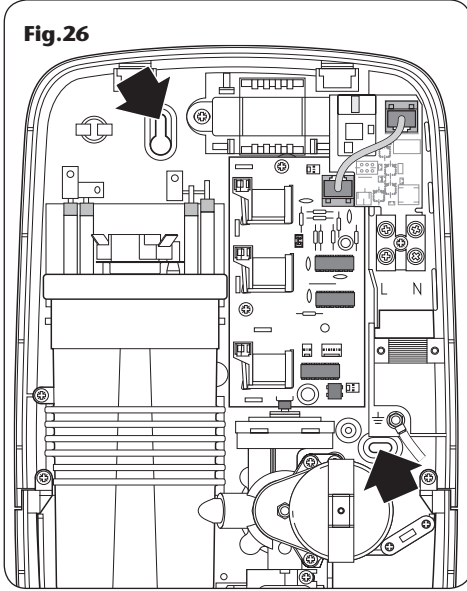

Fig.26



After choosing the site for the shower, use the backplate as a template and mark two fixing holes (**Fig.26**).

Drill and plug the wall.

(An appropriate drill bit should be used. If the wall is brick, plasterboard or a soft building block, appropriate wall plugs and screws should be fitted).

Screw top fixing screw into position leaving the base of the screw head protruding 6 mm out from the wall.

Entry positions for the mains water are from the bottom or from the rear.

Cable entry is via the top or rear.

Note: Deviations from the designated entry points will invalidate product approvals.

If a bottom surface entry is required for the mains cold water then the necessary hole will need to be cut out in the trimplate and cover (**Fig.27**).

If a surface cable entry from the top is required then the relevant hole in the backplate will need to be cut out (**Fig.28**).

Fig.27

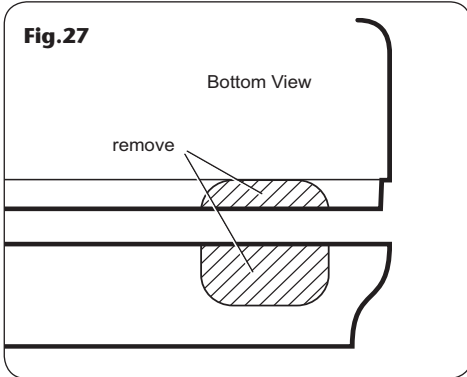

Hook the backplate over the top screw and fit the bottom fixing screw into position.

DO NOT fully tighten the screws at this stage, as the fixing holes are elongated to allow for out of square adjustment after the plumbing connections have been completed.

Fig.28

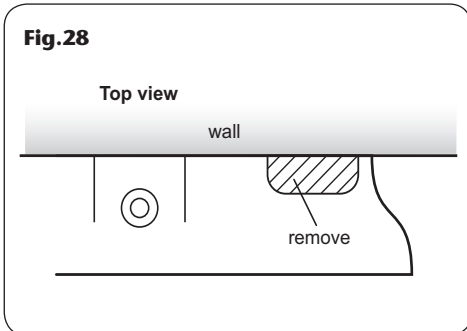

PLUMBING CONNECTIONS

Plumbing to be carried out before wiring.

DO NOT use jointing compounds on any pipe fittings for the installation.

DO NOT solder fittings near the shower unit as heat can transfer along pipework and damage components.

Compression fittings MUST be used to connect to the inlet of the remote pack (push-on fittings MUST NOT be used as the remote pack inlet may not fully enter this type of fitting to provide a watertight seal).

Note: An additional stopvalve, complying with Water Regulations, MUST be fitted in the mains water supply to the remote pack as an independent means of isolating the water supply should maintenance or servicing be necessary.

IMPORTANT: Before completing the connection of the water supply to the inlet of the remote pack, flush out the pipework to remove all swarf and system debris. This can be achieved by connecting a hose to the pipework and turning on the mains water supply long enough to clear the debris to waste.

Procedure

Turn off the water supply either at the mains stopvalve or the isolating stopvalve. Connect the mains water supply to the inlet of the remote pack via a 15 mm x 15 mm elbow compression fitting (*not supplied*).

If installing a feed pipe from the rear or bottom, the centre of the inlet valve to the wall surface is 20 mm (**Fig.29**).

Note: If entry is from the rear, the nut of the compression fitting will be partially behind the surface of the wall (**Fig.29**). This area must be left clear when plastering over the pipework in order to make the nut accessible for future adjustments.

DO NOT use excessive force when making these connections. It is strongly recommended to use a correct size open ended spanner. Using adjustable pipe grips may damage internal components.

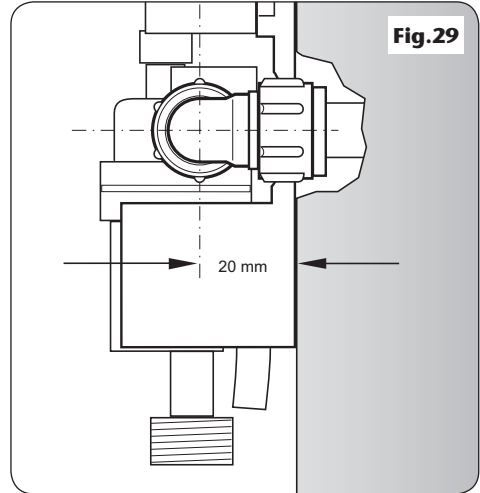
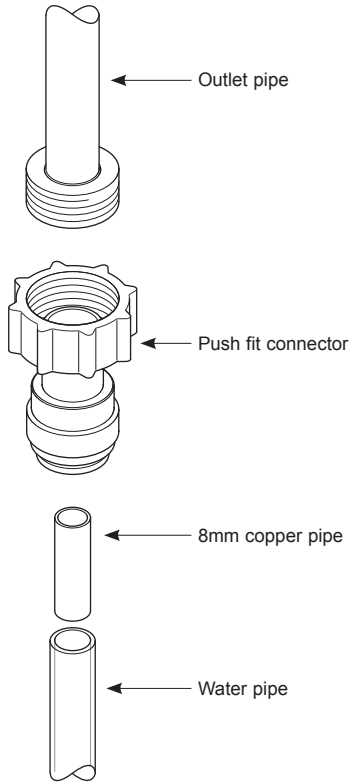

Fig.30



Make sure the backplate is square on the wall and tighten the two retaining screws which hold it to the wall.

Turn on the mains water supply and check for leaks in the pipework connection to the remote pack.

Note: At this stage no water can flow through the unit.

The remote pack is connected to the bulkhead outlet by means of a semi-rigid white 10 mm plastic water pipe which carries the heated water. This pipe can be channelled in a wall, plumbed through a wall or hidden behind a studded wall. The pipe can be run up to 3.5 metres away from the remote pack. Any surplus can be cut off as required.

Note: The water outlet does not need to be vertically above or below the control panel. If required the outlet adaptor and control panel can be placed on different walls as long as the control panel is not in the direct line of any spray when in use.

The end fittings consist of an 8mm copper pipe designed to slide flush into the water pipe to provide support and a push fit connector (**fig.30**).

Push on the fittings to both ends of the heated water pipe as follows (**fig.31**):

- Slide the 8mm copper pipe into the end of the water pipe so that it sits flush with the end.
- Slide the push fit connector onto the end of the pipe containing the 8mm copper pipe until it comes to rest.
- Gently pull the water pipe and push fit connector in opposite directions until the bottom section of the connector moves out by approximately 1mm. This will then have locked the connector into place. To remove the connector from the water pipe, reverse the operation.

Fig.31

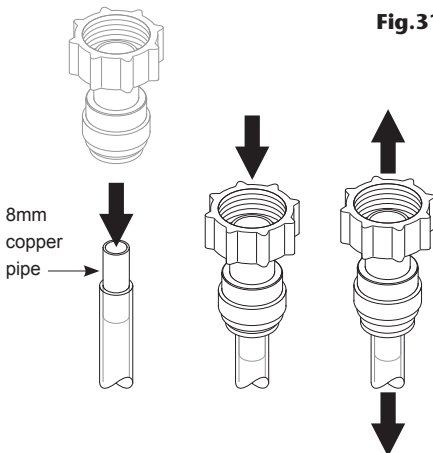

The pipe connects to the remote pack using the outlet extension which is screwed onto the remote pack outlet pipe. Alternatively, a 1/2" x 15 mm female thread to compression elbow can be screwed onto the outlet pipe, sealing the joint with PTFE tape.

FITTING THE BULKHEAD

Route the heated water pipe to the outlet position and assemble the fittings as shown in **Fig.30**. Connect the heated water pipe to a 1/2" BSP x 15 mm female thread elbow or straight coupler compression fitting (**Fig.32**).

Note: This fitting is not supplied as variations in installations requires selection of the most suitable fitting.

Screw the supplied male-thread connector into the female fitting (**Fig.33**) using PTFE tape to give a watertight joint.

Note: The male-thread connector supplied has a shoulder. If fitting into a flush wall, make an additional 8 mm allowance for this shoulder at the finished surface. The connector can be cut to size if required.

The threaded connector should protrude from the wall surface between 8 mm and 13 mm.

Make good the wall.

The bulkhead and its cover are supplied assembled. Separate the two halves by carefully prising apart at the smaller of the two elbow apertures.

Secure the elbow to the bulkhead body with the three screws supplied (**Fig.34**).

Screw the bulkhead assembly onto the threaded connector temporarily. Mark the position of the two fixing holes (**Fig.35**) securing the bulkhead to the wall.

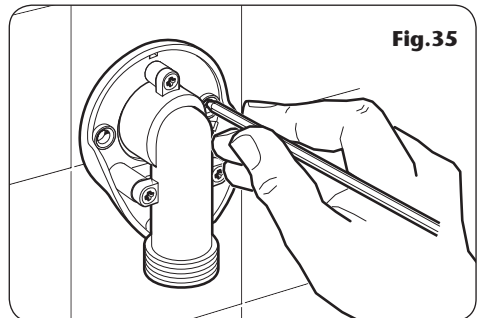
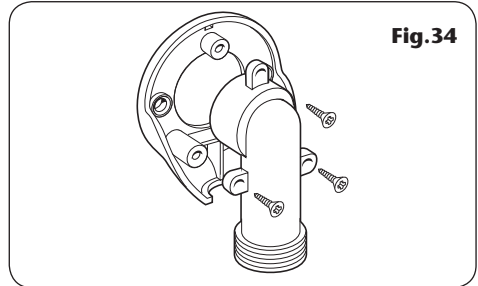
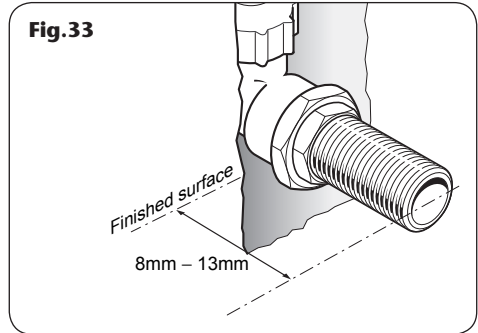
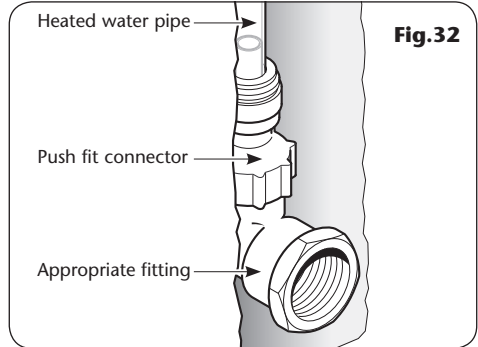

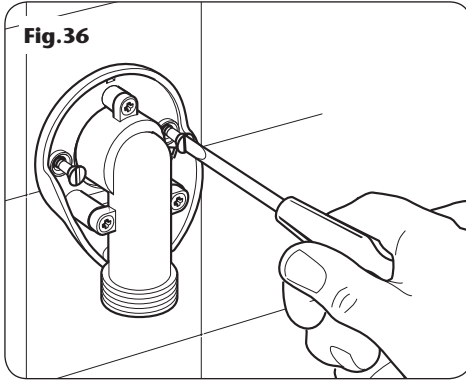

Note: If screw thread protrudes too far out of the wall, it can be cut to the correct length using a hacksaw.

Unscrew and remove the bulkhead assembly. Check the location of the pipe in the wall before drilling.

Drill and plug the wall.

(An appropriate drill bit should be used. If the wall is brick, plasterboard or a soft building block, appropriate wall plugs and screws should be fitted).

If fitting to a hollow wall structure, it may be preferable to secure the bulkhead by applying a bead of silicon seal to the back of the bulkhead.

Apply PTFE tape to the threaded connector.

Screw the bulkhead assembly onto the threaded connector until tight to the wall and the two fixing holes are aligned. Secure to the wall

(Fig.36).

Finish by clipping the cover onto the bulkhead making sure the protruding legs locate in the bulkhead body.

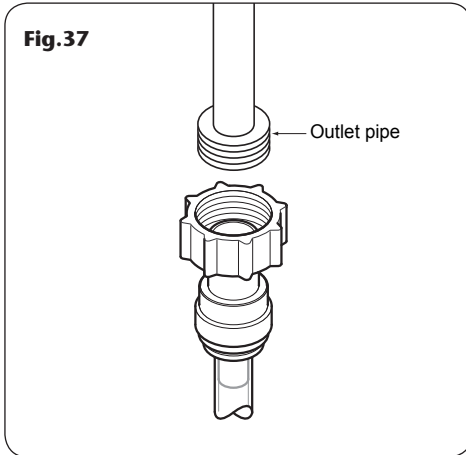

FITTING THE THROUGH CEILING WATER PIPE

WARNING!

The remote pack must not be positioned where it will be subjected to freezing conditions.

The remote pack is connected to the hose connector by means of two semi-rigid white 10 mm plastic water pipes which carry the heated water.

The 3.3 metre pipe connects to the remote pack using the push fit connector (**Fig.37**) which is screwed onto the remote pack outlet pipe. Alternatively, a 1/2" x 15 mm female thread to compression elbow can be screwed onto the outlet pipe, sealing the joint with PTFE tape.

Feed the 2 metre heated water pipe and PRD tube up the centre of the riser rail so that the pipe ends come out of the top of the riser rail. Insert the supplied 8 mm copper pipe into the end of the water pipe until it is flush. This will provide extra support to the plastic pipe.

Push fit the pipe end into the hose connector (**Fig.38**). Position the end of the PRD tube in the slot behind the recess in the bottom bracket (**Fig.39**). Push the hose connector into the recess in the bottom bracket and secure with the retaining clip (**Fig.39**).

In the loft, trim the 2 metre heated water pipe excess to length. Insert the 8 mm copper pipes into the end of both water pipes and then push fit both ends into the 10 mm fitting (**Fig.40**).

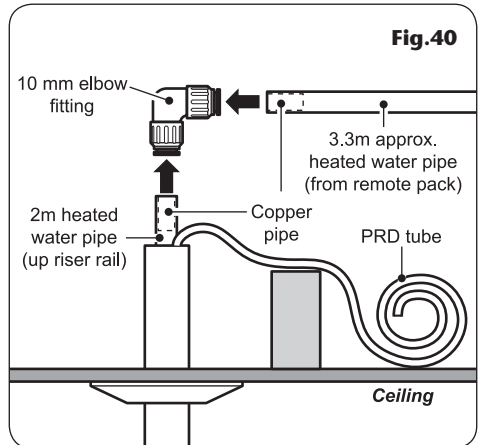
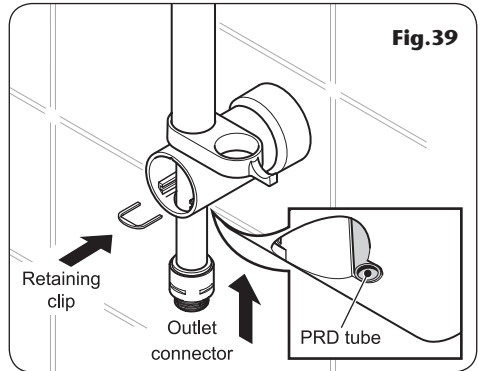
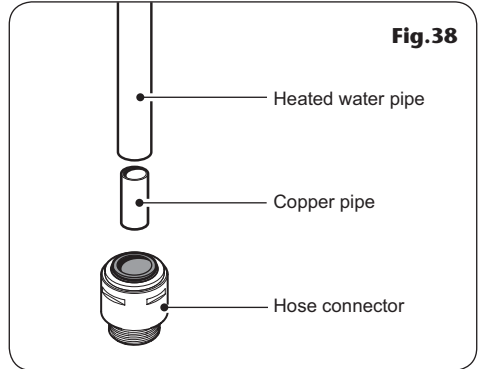

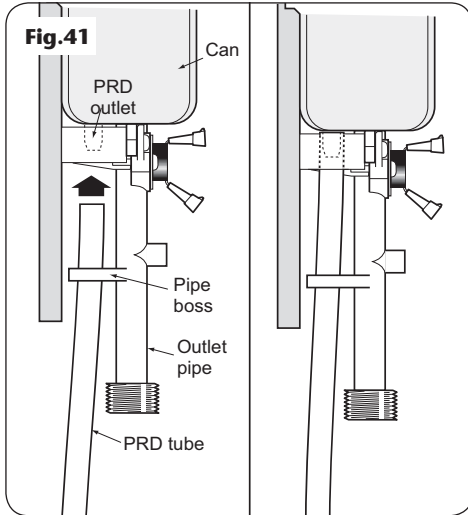

FITTING THE PRD OUTLET TUBE

Fit the clear plastic PRD tube through the can outlet pipe boss situated at the rear of the outlet pipe (**Fig.41**) and push firmly on to the PRD outlet.

Note: If the PRD tube has not been routed through the riser rail then the other end of the PRD tube needs to be directed to a suitable and visible waste; see P13 'Pressure relief safety device' for further details.

Note: Check the correct tubes have been used as they are similar in diameter and length (the PRD tube is clear).

IMPORTANT: Do not bend either the PRD tube or heated water pipe sharply as they will kink and restrict the water flow. If a tight bend is required in the heated water pipe cut the pipe and rejoin with standard 10 mm elbow compression fittings or push-fit connectors.

Insert a 25 mm length of 8 mm copper pipe (four are supplied, but more may be required) to provide support for the plastic pipe under the olive ring. If possible, the connections should be accessible so that adjustment can be carried out when required.

ELECTRICAL CONNECTIONS

SWITCH OFF THE ELECTRICITY SUPPLY AT THE MAINS.

Fig.42 shows a schematic wiring diagram.

The cable entry points are shown in **Fig.1**.

The cable can be surface clipped, hidden or via 20 mm conduit.

Note: Conduit entry can only be from rear.

Route the cable into the shower unit and connect to the terminal block (**Fig.43**) as follows:

Earth cable to terminal marked **E** 

Neutral cable to terminal marked **N**

Live cable to terminal marked **L**

IMPORTANT: Fully tighten the terminal block screws and check that no cable insulation is trapped under the screws. Loose connections can result in cable overheating.

Note: The supply cable earth conductor must be sleeved. The outer sheath of the supply cable must be stripped back to the minimum.

The supply cable must be secured either by routing through conduit or in trunking or by embedding in the wall, in accordance with current IEE regulations.

The use of connections within the unit, or other points in the shower circuit, to supply power to other equipment i.e. extractor fans, pumps etc. will invalidate the guarantee.

Fig.42

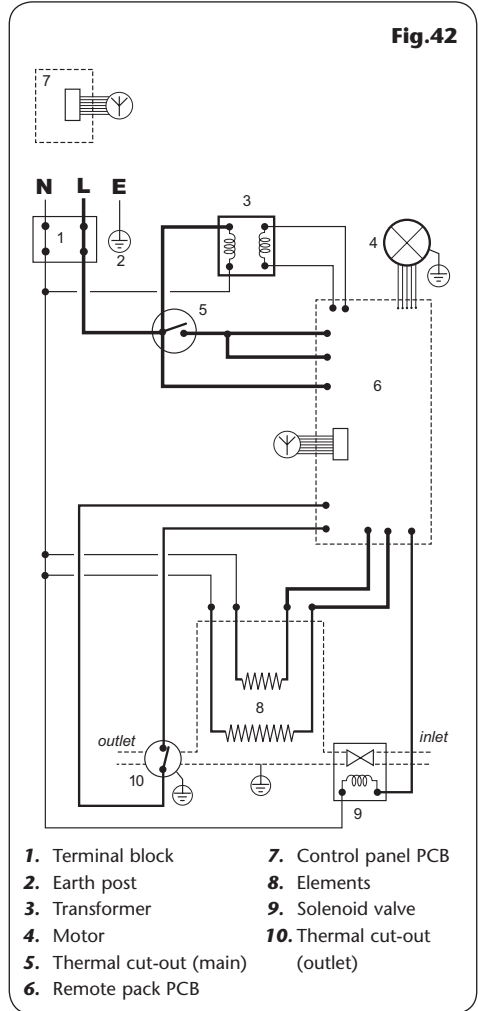
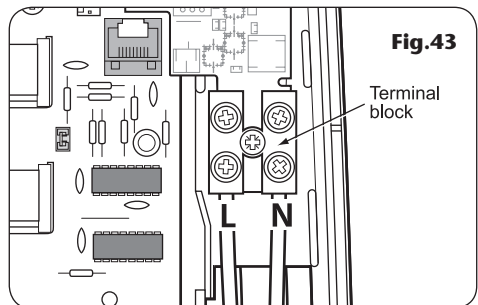
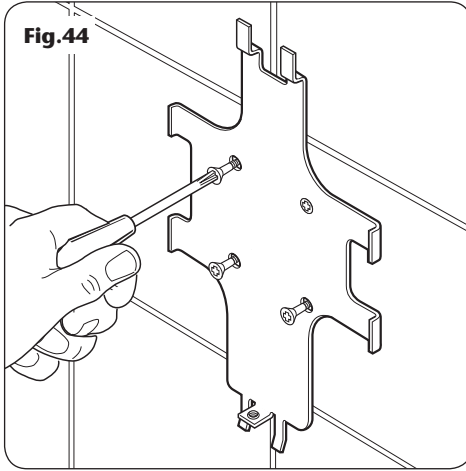

Fig.43





FITTING THE CONTROL PANEL BRACKET

Align the mounting bracket on the wall and mark the location of the four fixing holes.

Drill and plug the wall.

Refer to the 'Associating the Shower Unit' and 'Commissioning' sections before fitting the control panel to the wall.

Using the screws supplied, secure the mounting bracket to the wall (**Fig.44**).

Note: The mounting bracket **MUST** be fitted on the surface of the tiles.

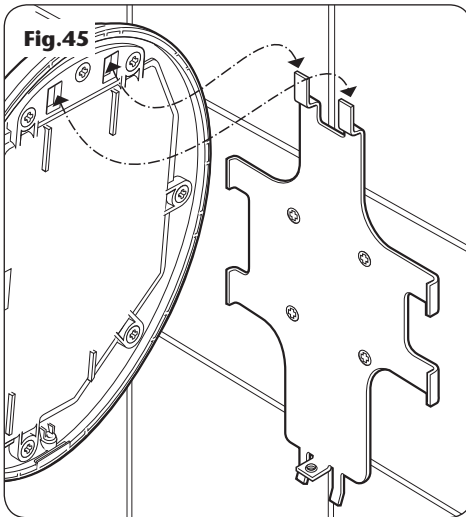

FITTING THE CONTROL PANEL

Hook the control panel over the lugs on the mounting bracket (**Fig.45**) and slide down into place. Secure in place with the single screw at the bottom of the control panel (**Fig.46**).

Note: To remove the panel undo the single retaining screw and lift off from the wall bracket lugs.

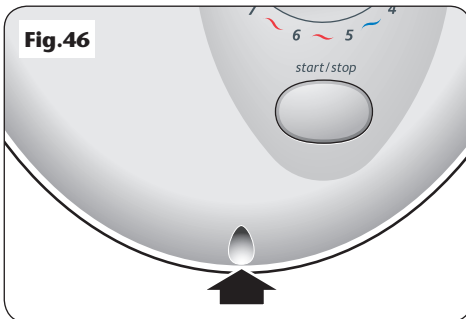

FITTING THE REMOTE PACK COVER

Refit the trimplate and secure with the two screws.

Before replacing the cover, check on the PCB that the purge pin is located on its two pins: the factory set position; see **Fig.50**.

Locate the tags on the cover into the holes on the backplate and guide into position. Secure the cover in position with the three retaining screws.

Note: DO NOT fully tighten at this stage as the remote pack cover is fitted temporarily in order to carry out the commissioning procedure.

ASSOCIATING THE SHOWER UNIT

Before the shower can be used the control panel must be associated to the remote pack. This will link the control panel to the specific remote pack.

Note: This procedure should be carried out before fitting the control panel to the wall.

Procedure

Insert the two AAA batteries (supplied) into the control panel (**Fig.47**).

IMPORTANT: Make sure to fit the batteries correctly otherwise the circuit board will be damaged.

Partially turn on the water supply to the shower – this will stop the PRD from operating. Turn on the electricity supply at the mains and then turn on the power to the remote pack at the isolation switch.

IMPORTANT: The remote pack will start its initialisation procedure and will beep intermittently for about thirty seconds. Once the remote pack has completed its initialisation procedure the intermittent beep will be replaced by a continual tone.

If the pack does not beep, switch off the remote pack at the mains and isolating switch, then remove the remote cover. To reset the module, move the pin connector across one pin (**Fig.48**). Refit the cover and switch on the power at the mains and isolating switch – the remote pack will start its initialisation procedure.

With the remote pack emitting a continual tone, simultaneously press and hold the HIGH and COLD buttons (**Fig.49**) and then press and release the Start/Stop button.

Once the indicators start flashing release the high and cold buttons. When the LEDs extinguish and the continual tone stops the control panel and remote pack will be associated.

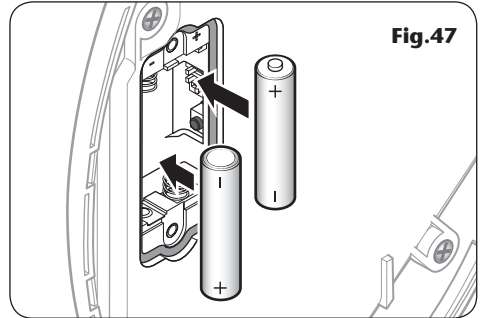

Fig.47

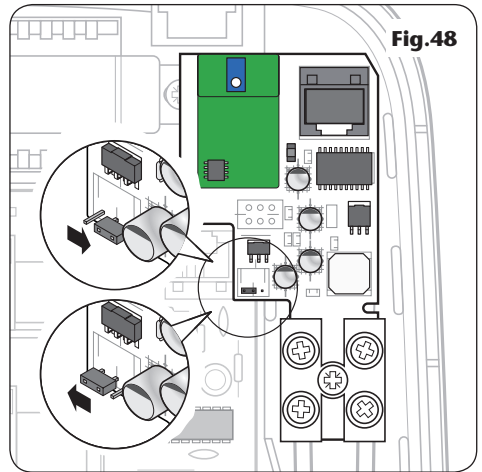

Fig.48

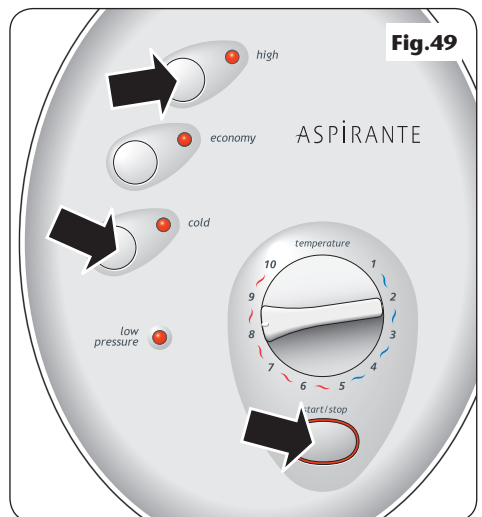
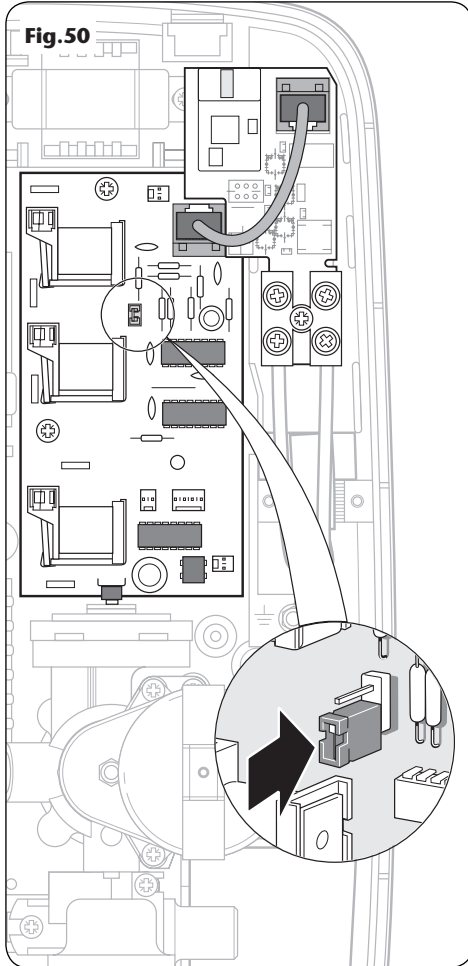

Fig.49



COMMISSIONING

Setting up the remote pack

Press the START/STOP button. The 'HIGH' and 'POWER ON' indicators will light for a few seconds and after a short delay water will begin to flow.

It will take about thirty seconds for a smooth flow of water to be obtained while air and any debris in the system is being flushed from the shower.

Note: During the commissioning procedure the low pressure indicator will flash every half second.

Once the flushing procedure is complete press the START/STOP button. The 'POWER ON' indicator will light up and the shower will go into the phased shutdown procedure. Once complete, the light will extinguish and water will cease to flow.

Switch off the electricity supply to the shower at the isolating switch.

Purge pin procedure

On the remote pack, undo the top and bottom screws and remove the cover. Inside the remote pack, on the PCB, is the purge pin (**Fig.50**). Pull the purge pin off its two pins and, in order for it to be used at a later date, replace it onto one of the pins.

Refit the cover and secure with the three screws.

Turn on the electricity supply at the isolating switch and then turn on fully the water supply.

Once the installation of the riser rail is complete the shower is ready for normal operation.

OPERATING THE SHOWER

IMPORTANT: Make sure the commissioning procedure has been carried out. Failure to do so will damage the unit and invalidate the guarantee.

To start the shower

Note: When first switched on at the isolation switch, the shower will attempt to initialise itself. This will last for about thirty seconds. Any attempt to start the shower before the initialisation procedure is complete will cause the control panel to run through the start-up routine. Press the START/STOP button and the 'POWER ON' and 'HIGH' indicators immediately light up and remain lit for two seconds.

All lights will then extinguish and water will begin to flow.

To stop the shower

Press the START/STOP button. The phased shutdown will begin and water will cease to flow after a few seconds. Note the 'POWER ON' indicator surround stays lit until phased shutdown is complete.

To use the control buttons

There are three control buttons – HIGH, COLD and ECONOMY – as shown in **Fig.51**. Upon selection, each button will light up for two seconds to indicate the mode chosen.

The upper button is a high power setting which allows the highest flow achievable for your preferred temperature. This setting should normally be regarded as optimum shower performance throughout the year. Temperature adjustment at this setting is via the temperature control.

The centre button is an economy setting for using less power when the ambient mains water temperature is high during hot months. Temperature adjustment at this setting is via the temperature control.

Note: If the stated flow rate required for the unit cannot be met due to low water pressure, it will be necessary to operate the unit on this setting during the warmer months because of flow rate limitations entering the unit.

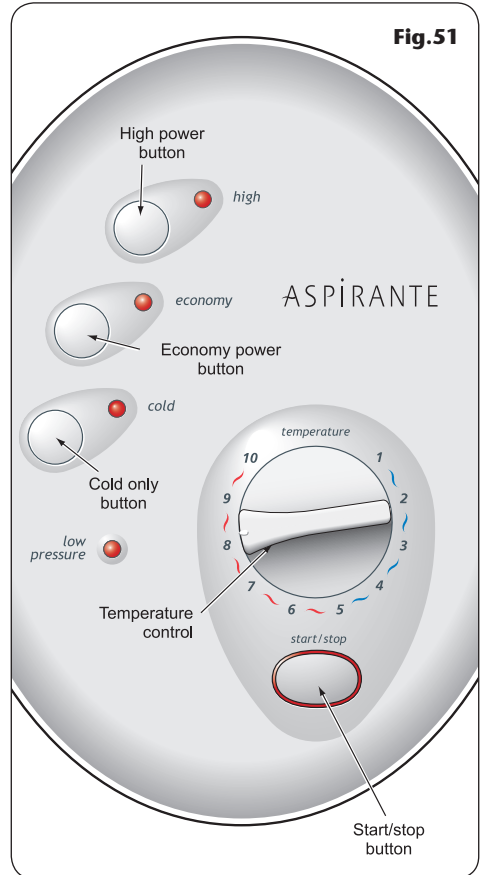



The lower button is for cold water only. Adjusting the temperature control at this setting will only change the force of the water from the showerhead (it will not alter the water temperature).

To adjust the shower temperature

The water temperature is altered by increasing or decreasing the flow rate of the water through the shower using the temperature control (**Fig.51**).

After obtaining your preferred showering temperature, the number can be remembered and left as the normal setting and should only need to be altered to compensate for seasonal changes in ambient water temperature.

Note: The preferred number on 'ECONOMY' will give a different temperature to the same number position on 'HIGH'.

To decrease the shower temperature

Turn the temperature control anti-clockwise (**Fig.52**). This will increase the flow of water through the shower and is indicated by lower numbers.

To increase the shower temperature

Turn the temperature control clockwise (**Fig.53**). This will decrease the flow of water through the shower and is indicated by higher numbers.

CAUTION: It is advisable to be certain that the showering temperature is satisfactory by testing with your hand before stepping under the showerhead. There will always be a time delay of a few seconds between selecting a flow rate and the water reaching the stable temperature for that flow rate.

CAUTION: It is recommended that persons who may have difficulty understanding or operating the shower controls should not be left unattended when showering. Special consideration should be given to young children and the less able bodied.



WARNING:

The shower will ALWAYS start on the "HIGH" setting even if it was last used and switched off on the "ECONOMY" setting.

When the shower is in use, DO NOT STOP and then RESTART the shower while under the showerhead. The shower will default to the "HIGH" setting and a slug of HOT water will be discharged from the showerhead.

OPERATING FUNCTIONS

Low pressure indicator (Fig.54)

If this indicator flashes every half a second, it means the water pressure has fallen below the minimum required for correct operation of the shower, resulting in the low pressure cut-out operating. This switches off power to the heating elements preventing any maintained temperature rises (water will continue to flow).

When adequate water pressure returns, the 'LOW PRESSURE' indicator will extinguish and the power will automatically be restored to the power setting at the time of the interruption.

Low battery indicator (Fig.54)

If the battery is running low then the 'LOW PRESSURE' indicator will flash every four seconds while the control panel is on.

Selector mode indicators (Fig.54)

Next to each control button there is an LED which lights up for two seconds when the button is pressed, showing which shower mode is in operation.

Phased shutdown

In use, when the START/STOP button is pressed once again, power is switched off to the elements. Water continues to flow for a few seconds, flushing out the system.

Note: The shower should always be switched off in this manner before isolating at the double pole isolating switch. Failure to do so will cause the 'POWER ON' indicator to flash for thirty seconds and stay lit for another thirty seconds before extinguishing.

Overheat cut-out

During normal operation if an overheat temperature is sensed, power to the elements will be reduced. Water will continue to flow. When the temperature has cooled sufficiently, power to the elements will be automatically restored to the previous setting at the time of interruption.

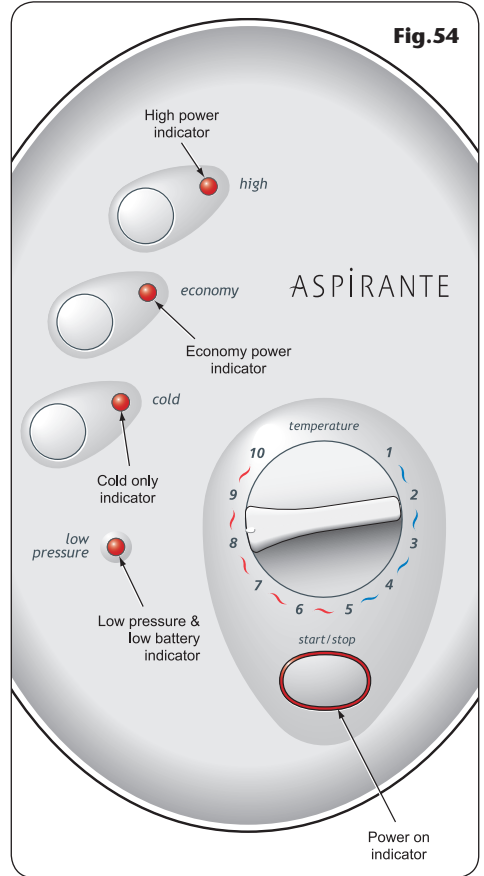

Note: In normal use, it is in order to leave the water supply permanently on to the shower unit but, as with most electrical appliances, **the unit must be switched off at the isolating switch when not in use.**

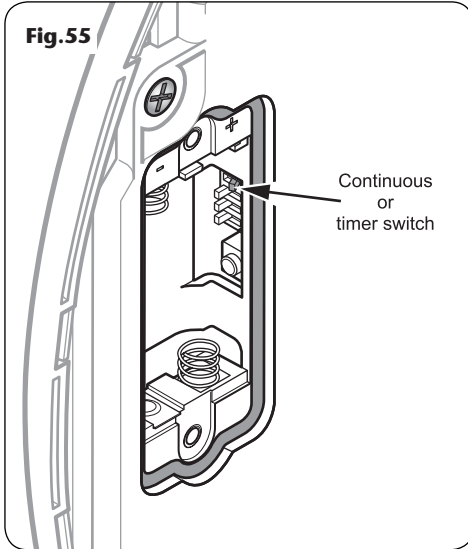

Safety cut-out

The unit is fitted with a non-resettable over-temperature safety device. In the event of abnormal operation which could cause unsafe temperatures within the unit, the device will disconnect the heating elements. It will require a visit from a qualified engineer to determine the nature of the fault and replace the safety device, once the unit has been repaired.

CONTINUOUS AND TIMED OPERATION

In the control panel battery recess is a switch which allows selection between continuous and timed operation of the shower (**Fig.55**).

Changing the switch from continuous operation to timed operation will set up the shower so that once started, it will run for a maximum of ten minutes before automatically shutting down.

BATTERY LIFE

The estimated battery life of the control panel, if used on average for ten minutes four times a day, will give an approximate battery life span of 1 year 7 months. This assumes that two 1.5 V alkaline batteries are used.

Note: DO NOT use rechargeable batteries in the control panel as these will interfere with the low battery indicator operation.

INSTRUCTIONS FOR INSTALLERS AND SERVICE ENGINEERS ONLY

CLEANING THE FILTER

It is recommended that the filter is periodically cleaned in order to maintain the performance of the shower. It is essential that this operation is carried out by a competent person.

SWITCH OFF THE ELECTRICITY SUPPLY AT THE MAINS.

The inlet filter is situated inside the solenoid inlet (**Fig.56**).

To gain access to the filter, remove the cover then disconnect and remove the compression fitting. Also, depending on the incoming pipework arrangements, if there is not enough slack in the pipework, it could mean the removal of the unit from the wall.

When cleaning the filter, DO NOT use a sharp object, as it will cause damage. It is preferable to use an old toothbrush or similar.

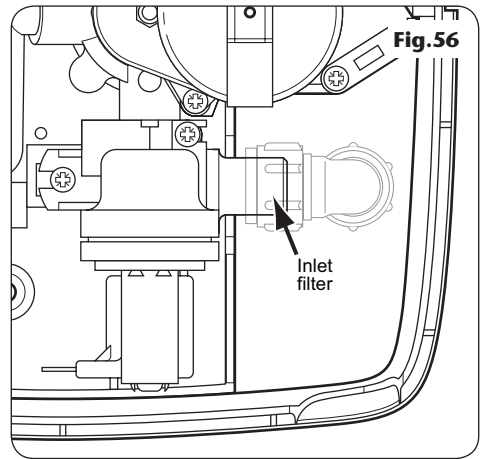

Spare parts

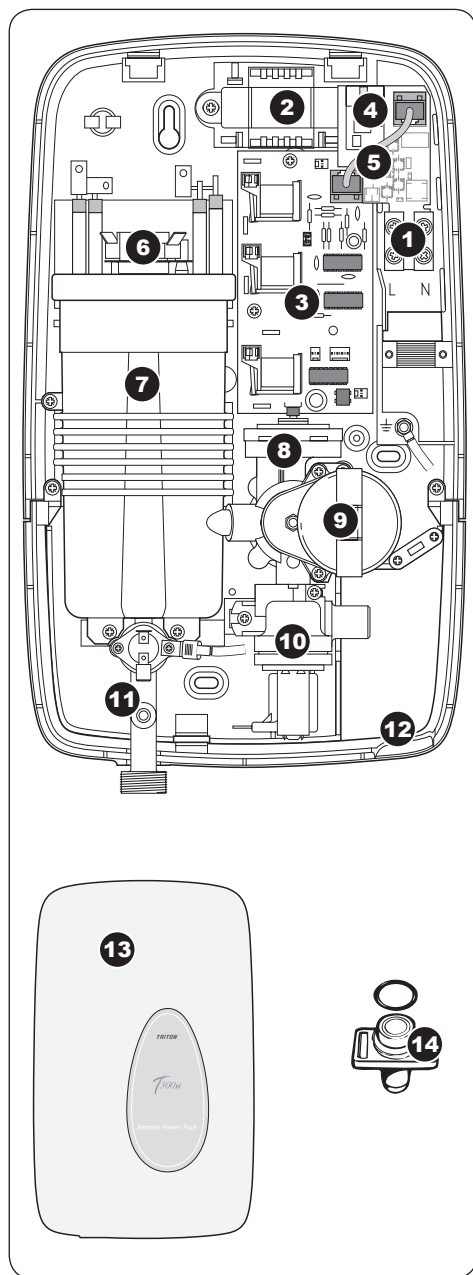

Ref.	Description	Part No.
1.	Terminal block	
	9.5kW	82200930
	10.5kW	82200850
2.	Transformer	22005020
3.	Remote pack PCB	
	9.5kW	7072570
	10.5kW	7072985
4.	RF module	7073501
5.	RF data cable	P15310901
6.	Thermal cut-out (main)	22009860
7.	Heater can assembly	
	9.5kW	84500290
	10.5kW	84500670
8.	Stabiliser valve assembly	82600780
9.	Stepper motor	82300170
10.	Solenoid valve	83304130
11.	Outlet pipe assembly	85000100
12.	Trimplate	7051754
13.	Remote pack cover	85200030
14.	PRD & 'O' ring	83301330

Spare parts

Ref.	Description	Part No.
15.	Control panel PCB	7073500
16.	Control panel assembly	S15310801
17.	Control panel mounting bracket	7012512
18.	Bulkhead assembly	85500230
19.	All thread fitting	7032915
20.	Heated water pipe fittings kit	83304290
-	PRD tube 5.5 m (clear)	22010210
-	Heated water pipe 2 m (white)	22011390
-	Heated water pipe 3.5 m (white)	22010200
-	10 mm push-fit elbow	22011380
-	Wire set	83306410

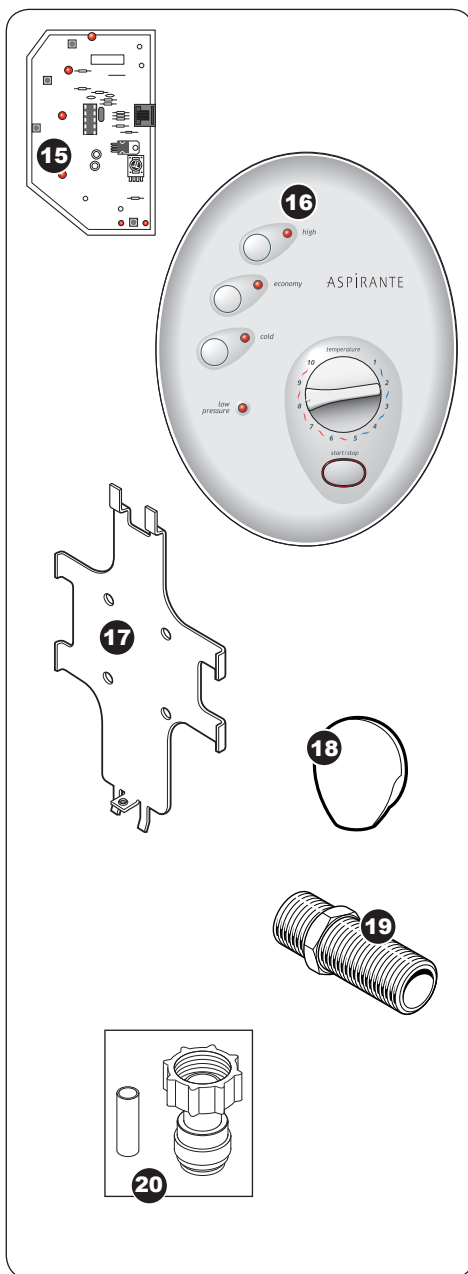

FAULT FINDING

IMPORTANT: Switch OFF the electricity at the mains supply and remove the circuit fuse before attempting any fault finding inside the unit.

Problem/Symptom	Cause	Action/cure
1 Shower inoperable, no water flow.	1.1 Interrupted power supply.	1.1.1 Blown fuse or circuit breaker. Check supply. Renew or reset fuse or circuit breaker. If it fails again, consult a qualified electrician. 1.1.2 Power cut? Check other appliances and if necessary, contact local Electricity Supply Company.
	1.2 Unit malfunction.	1.2.1 Have unit checked. Ring Customer Service.
2 Water too hot.	2.1 Not enough water flowing through the shower.	2.1.1 Increase the flow rate via temperature control. 2.1.2 Blocked showerhead – clean or replace blocked sprayplate/cartridge.
	2.2 Blockage in supply.	2.2.1 Check if stop taps are fully open. Check if blockage in inlet filter.
	2.3 Increase in ambient water temperature.	2.3.1 Switch to economy power setting and readjust flow rate to give required temperature.
3 Water temperature cycling hot/cool at intervals.	3.1 Heater cycling on outlet thermal cut-out.	3.1.1 See 'Water too hot' causes 2.1, 2.2 and 2.3 and their appropriate action/cures. If it continues, contact Customer Service.
4 Water too cool or cold.	4.1 Too much flow.	4.1.1 Reduce the flow rate via temperature control.
	4.2 Water pressure below minimum stated on rating label.	4.2.1 Check low pressure indicator. If lit, continue with remainder of checks. If not lit, see 4.1 & 4.4.
		4.2.2 Is water supply mains or tank fed?
		4.2.3 If tank fed, replumb to mains water supply or see 4.2.5.
		4.2.4 If mains fed, make sure that mains stop valve is fully open and that there are no other restrictions in the supply while shower is in use, or see 4.2.5.
4.2.5 Fit a pump to give minimum pressure; contact Customer Service for advice.		
4.3 Reduction in ambient water temperature.	4.3.1 Switch to full power setting and readjust the flow rate via the temperature control to give required temperature.	

FAULT FINDING

Problem/Symptom	Cause	Action/cure
	4.4 Electrical malfunction or safety cut-out has operated.	4.4.1 Have unit checked by suitably qualified electrician or contact Customer Service.
5 Cold indicator light on and low pressure indicator light flashing.	5.1 Purge pin not placed correctly. 5.2 Low water pressure.	5.1.1 Isolate the electricity supply. Remove remote pack cover and place purge pin on one pin only. 5.2.1 Wait until the water pressure resumes to normal (flashing low pressure indicator extinguishes). 5.2.2 Check if stop taps are fully open. Check if blockage in supply pipe.
6 Temperature varies from normal to cold intermittently during showering.	6.1 Water pressure dropped below minimum required (indicator flashing).	6.1.1 Wait until the water pressure resumes to normal (flashing low pressure indicator extinguishes).
7 Pressure relief device has operated (water ejected from PRD tube).	7.1 Blocked showerhead. 7.2 Twisted/blocked flexible shower hose. 7.3 Showerhead not removed while commissioning.	7.1.1 Clean or replace blocked sprayplate or cartridge and then fit a new PRD. 7.2.1 Check free passage through hose. Replace hose if necessary and then fit new PRD. 7.3.1 Fit new PRD. Commission unit with showerhead removed.
8. Low pressure indicator flashing every 4 seconds.	8.1 Batteries running low.	8.1.1 Replace batteries.
9. Power on indicator flashes and unit switches itself off.	9.1 Interference with wireless signal.	9.1.1 Reassociate the control panel to the remote pack.

Entry Points (remote pack)

Diagram Key:



Water Entry Points



Cable Entry Points

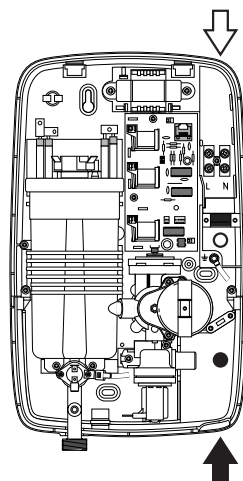

WEEE Directive – Policy Statement

As a producer and a supplier of electric showers, Triton Showers is committed to the protection of the environment via our own environmental policy and the compliance with the **WEEE directive**.

Triton Showers is fully registered with the Environment Agency under the following schemes:

Repic: Producers take-back scheme (PTS), registration number WEE/EJ3466QV

Valpak: Distributor take-back scheme (DTS), registration number 9659

All our electric products are labelled accordingly with the crossed out wheeled bin symbol. This indicates, for disposal purposes at end of life, that these products must be taken to a recognised collection points, such as local authority sites/local recycling centres; this will be free of any charges. **Do not return to Triton Showers.**



UK SERVICE POLICY

In the event of a product fault or complaint occurring, the following procedure should be followed:

1. Telephone Customer Service on **0844 980 0750** having available, your details including post code, the model number and power rating of the product, together with the date of purchase and, where applicable, details of the particular fault.
2. If required, the Customer Service Advisor will arrange for a qualified engineer to call.
3. All products attended to by a Triton service engineer must be installed in full accordance with the Triton installation guide applicable to the product. *(Every product pack contains an installation guide, however, they can also be bought via our Customer Service Spares Department).*
4. Our engineer will require local parking and if a permit is required this must be available to the engineer on arrival at the call.
5. It is essential that you or an appointed representative (*who must be over 18 years of age*) is present for the duration of the service engineer's visit. If the product is in guarantee you must produce proof of purchase.
6. Where a call under the terms of guarantee has been booked and the failure is not product related (*i.e. scaling and furring, incorrect water pressure, pressure relief device operation or electrical/plumbing installation fault*) a charge will be made. A charge will also be issued if nobody is at home when the service engineer calls or adequate parking/permit is not available.
7. If the product is no longer covered by the guarantee an up front fixed fee will be charged before the site visit.
8. Should proof of purchase not be available on an "in-guarantee" call, or should the service engineer find that the product is no longer under guarantee, the engineer will charge the same fixed price and the customer will be expected to pay the engineer before he leaves. If payment is not made on the day an administration charge will be added to the fixed charge.
9. If a debt is outstanding from a previous visit, or from any other Triton purchase. Triton reserves the right to withhold service until the debt has been settled.
10. Triton takes the health, safety and wellbeing of its employees very seriously and expects customers to treat all staff members with respect. Should any employee feel threatened or receive abuse, either verbally or physically, Triton reserves the right to withhold service and will support the employee with a legal prosecution.

Replacement Parts Policy

It is the policy of Triton Showers to maintain parts availability for the duration of production and a period of 5 years thereafter in accordance with industry standards. In the event of a spare part not being available a substitute part will be supplied.

Spare parts can be ordered via our online spare parts store, or by telephoning Triton Spares Department. Payment should be made by credit/debit card (*excluding American Express or Diners Card*). Payment can also be made by pre-payment of a pro-forma invoice, by cheque or postal order.

Telephone orders are based on information given during of the call. Before contacting Triton, please verify your requirements using the information contained in the user guide. Triton cannot accept liability for incorrect part identification.

TRITON STANDARD GUARANTEE

Triton guarantee this product against all mechanical and electrical defects arising from faulty workmanship or materials for a period of two years for domestic use only, from the date of purchase, provided that it has been installed by a competent person in full accordance with the fitting instructions.

Any part found to be defective during this guarantee period we undertake to repair or replace at our option without charge so long as it has been properly maintained and operated in accordance with the operating instructions, and has not been subject to misuse or damage.

This product must not be taken apart, modified or repaired except by a person authorised by Triton. This guarantee applies only to products installed within the United Kingdom and does not apply to products used commercially. This guarantee does not affect your statutory rights.

What is not covered:

1. Breakdown due to: *a)* use other than domestic use by you or your resident family; *b)* wilful act or neglect; *c)* any malfunction resulting from the incorrect use or quality of electricity, gas or water or incorrect setting of controls; *d)* failure to install in accordance with this installation guide.
2. Claims for missing parts once the product has been installed.
3. Repair costs for damage caused by foreign objects or substances.
4. Total loss of the product due to non-availability of parts.
5. Compensation for loss of use of the product or consequential loss of any kind.
6. Call out charges where no fault has been found with the appliance.
7. Call out charges where the water supply cannot be isolated, this includes consequential losses arising from unserviceable supply valves.
8. The cost of repair or replacement of pressure relief devices, showerheads, hoses, riser rails and/or wall brackets, isolating switches, electrical cable, fuses and/or circuit breakers or any other accessories installed at the same time.
9. The cost of routine maintenance, adjustments, overhaul modifications or loss or damage arising therefrom, including the cost of repairing damage, breakdown, malfunction caused by corrosion, furring, pipe scaling, limescale, system debris or frost.

For the latest Terms & Conditions, please see:
www.tritonshowers.co.uk

Triton Showers
Triton Road
Nuneaton
Warwickshire CV11 4NR

Triton is a division of Norcros Group (Holdings) Limited

Customer Service: ☎ **0844 980 0750**

Trade Installer Hotline: ☎ **0844 980 0730**

Fax: **0844 980 0744**

www.tritonshowers.co.uk

E-mail: serviceenquiries@tritonshowers.co.uk

Extended Warranty AVAILABLE NOW. Call 0844 980 0740 for more details.