

CHATSWORTH

U-Shaped Shower Curtain Rail

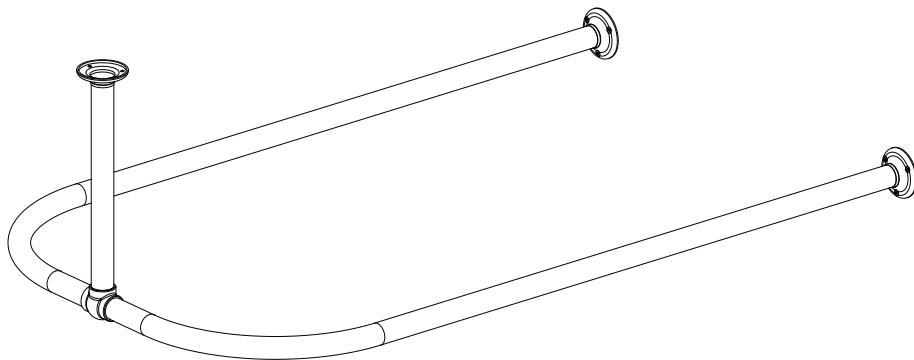

Fitting Instructions

Please follow them carefully and
leave this manual with end user

Items Included:

- A. Curtain Rail
- B. Securing Bracket
- C. Rawl Plugs (x9)
- D. Screws (x9)

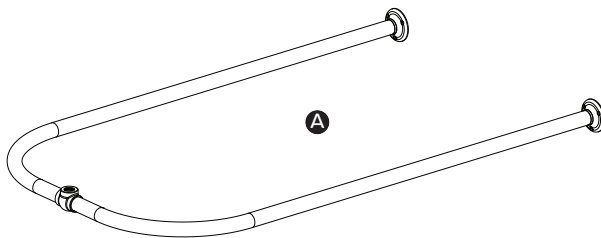

Tools Required (Not included):

Ensure the appropriate PPE is used during installation



Power Drill



Spirit level



Screwdriver

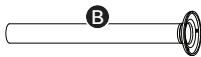

*Diagrams are for illustration purposes only. Your Shower
Curtain Rail may superficially differ from this drawing
however the installation guide steps still apply.*

Recycling and Disposal:

Please recycle the packaging in accordance with your local government regulations on waste handling and follow the same advice at the end of the products life.

Before you begin:

1. **We recommend that this product is installed by a qualified tradesperson.** Victorian Plumbing Ltd. accept no liability for products incorrectly installed or any damage to the floor, walls, plumbing, curtain rail, or personal injury during installation.
2. **Check the chosen wall/ceiling space for any pipes/cables prior to drilling.**
3. Observe all local building codes & regulations.
4. **Ensure the shower curtain rail is securely fixed to the wall/ceiling.**
5. Unpack the product then read these instructions before proceeding. Inspect the product for damage. If any damage is found, contact our Customer Relations team.

Installation:

Step 1:

Screw the 'bracket' into the 'Curtain Rail'. Position the curtain rail up to your chosen wall/ceiling, then mark the fixing points on the brackets to the wall/ceiling.

Ensure the markings are level using a spirit level.

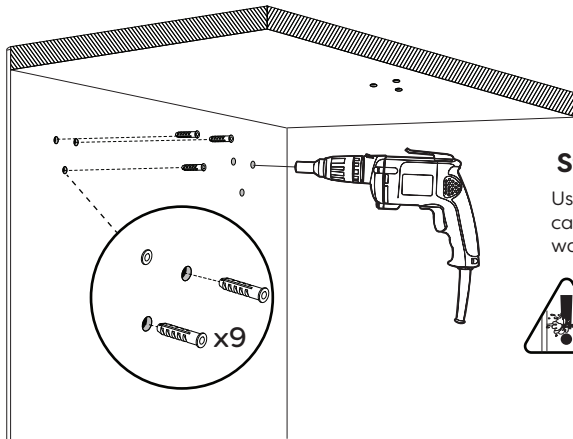
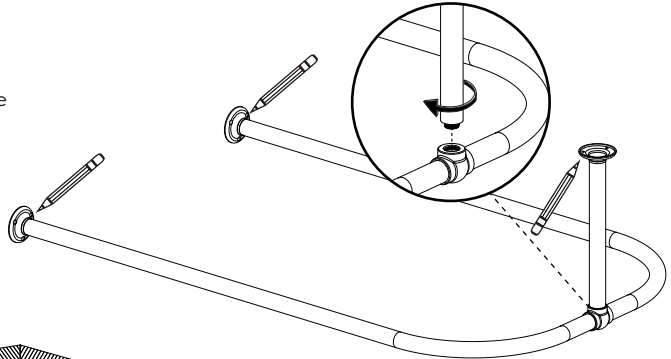

Step 2:

Using an appropriate sized drill bit, carefully drill the holes in the wall/ceiling, then insert the rawl plugs.



Warning:
Check the chosen wall/ceiling space for any pipes/cables prior to drilling!

Step 3:

Position the 'Curtain Rail' over the rawl plugs in the wall/ceiling. Secure the curtain rail into place using the screws provided, tighten with a screwdriver.

Ensure the curtain is level using a spirit level.

