

Side Panel

Instruction Manual

H3R



PO Box 125, Whitworth Avenue,
Aycliffe Business Park,
Co Durham DL5 6WX

To obtain a copy of the Declaration of Performance for this product, please go to: www.ce-dop.com, contact us on +44 (0) 1325 328034, or write to us at the above address, quoting the product reference number where possible.

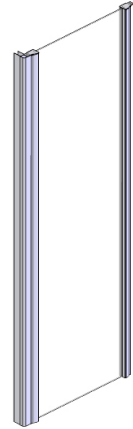

IMPORTANT INFORMATION

Be aware toughened glass can shatter if not handled correctly. It should not be subjected to any sharp impact and it is essential to protect the glass by resting it on a soft protective surface during installation such as cardboard or carpeting. It is recommended to wear PPE at all times during installation.



PRE-INSTALLATION CHECKS

1. Check you have the correct product. Please look at the labels on the side of the product packaging.
2. Check all the product components are in the box and the fixing kits.
3. Unpack your product and handle it with care.
4. Please check the product for defects or damage, once the installation has commenced we cannot accept responsibility for any defects or damage.
5. Please take time to read these instructions prior to installing your product.
6. Before you commence any drilling check there are no hidden electrical cables and/or water pipes.
7. No attempt should be made to re-work the toughened safety glass.
8. The installation of the product should be performed by two persons.
9. It is strongly recommended that the walls the product is going to be installed on are vertical.
10. It is strongly recommended the product is fitted on a tiled surface or similar waterproof surface.
11. It is strongly recommended the walls are tiled and grouted before the product is installed.
12. If the walls and/or the tray are not level you will not achieve maximum adjustment of the product.
13. Pictures used are for illustration purposes only, product designs may alter slightly as a result of continuing product development.
14. We do not stipulate where the European Standard Kite Mark should be positioned on the glass when being factory assembled.
15. Please note that some natural misting may occur when you remove this product from its packaging, due to the addition of the glass protection pre-coating. If this does occur this can easily be removed with a soft, dry cloth.

Component Check List: Supplied

Description	Quantity
Corner Post	1
Side Panel	1

Fixing Kit Components

Description	Quantity
6mm Screws	3
9mm Screws	3
Screw Bases	6
Screw Cover Caps	6
Top Cap (Left Hand)	1
Top Cap (Right Hand)	1
Corner Cap (Left Hand)	1
Corner Cap (Right Hand)	1
2.5mm Drill Bit	1

Equipment Check List: Not Supplied

Description
6mm Masonry Drill Bit
4.5mm Drill Bit
Mains / Battery Drill
Spirit Level
Screwdriver
Sealant Gun
Bathroom Sealant
Tape Measure
Pencil
Additional Fixings if going into Plasterboard etc.

CONSUMER GUARANTEE

Please make sure the purchaser/end user completes and returns the guarantee card which is enclosed with this product. Failure to validate the Guarantee will mean only the 1 Year Statutory Guarantee will apply.

Step 1 - Preperation

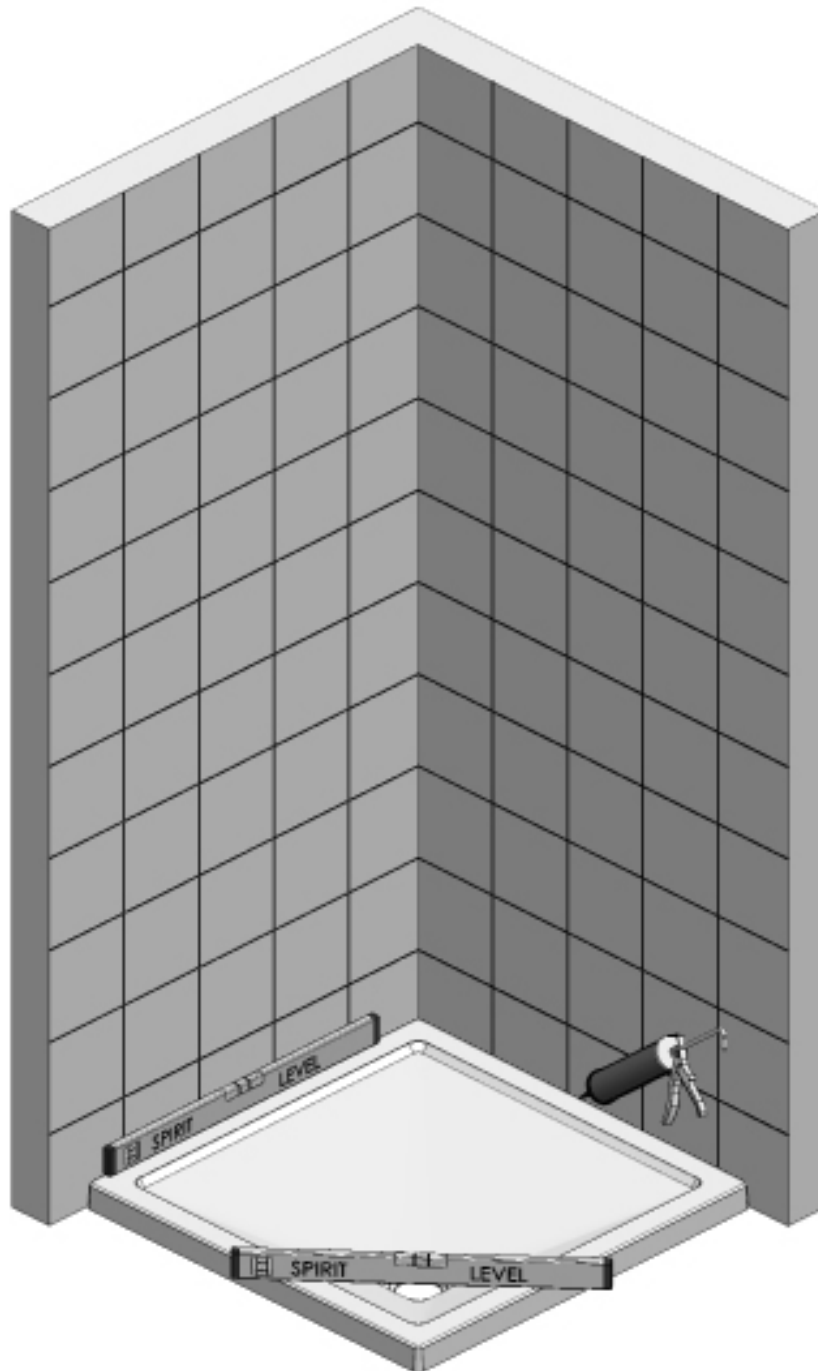

1. Ensure the Tray is completely level on all sides using a Spirit Level.
 - **The bubble should be in the centre of the 2 lines on the Spirit Level.**
2. Check that there is no movement in the Tray by standing in it.
3. Fill the tray with water to check all plumbing for leaks.
 - **Note: Please ensure that the Tray is installed as per Manufacturers' Instructions.**
4. The tray should be fully sealed along the tiled walls prior to installation with a Bathroom Sealant (not supplied).
5. Prior to commencing installation of the Enclosure and once the sealant has set, spray the shower handset around all joints to check for leaks.
 - **Allow 24 hours for the Bathroom Sealant to fully cure.**

Step 2 - Fitting the Wall Profiles

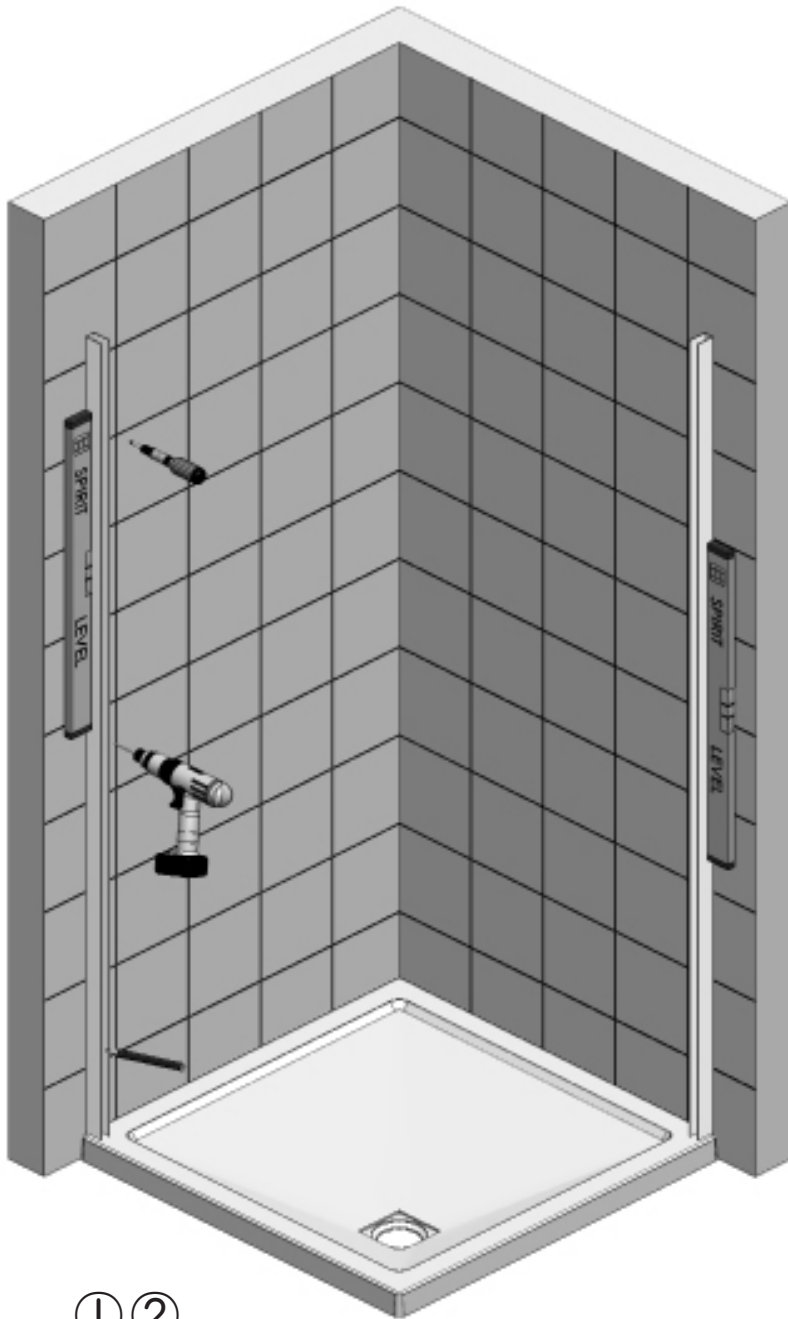

① ②

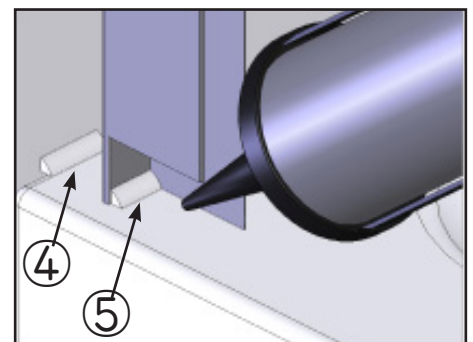
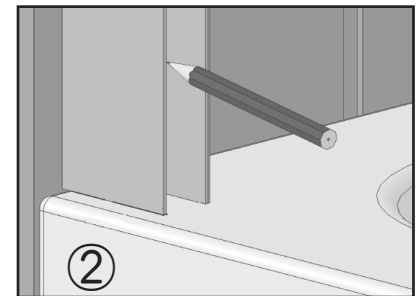
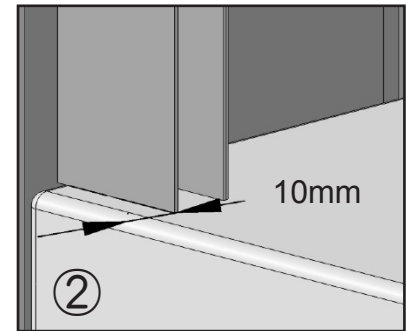
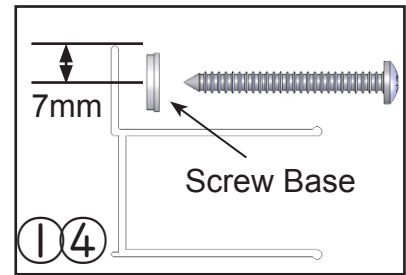

1. On both Wall Profiles drill three 4.5mm holes through the lip. Place them 7mm in from the edge and approximately 100mm from each end and the other positioned in the centre.
 - **Drill the holes from the back (through the face that goes to the wall) - deburr all holes.**
2. Place both Wall Profiles 10mm in from the outside of the tray. Make sure that both wall profiles are completely vertical using a spirit level and mark the wall through the holes with a pencil.
3. Drill the wall with a 6mm Masonry Drill Bit (not supplied) where the Wall Profiles are to be positioned. Fit the Wall Plugs supplied (if going in to a brick or block wall). If going into a plasterboard wall you will need to purchase appropriate wall fixings. Wipe clear all debris from the Tray before referring to the next stage.
4. Where both Wall Profiles are to be positioned on the Tray, place a bead of Bathroom Sealant (not supplied) the width of the Wall Profile along the tiled wall. Screw the Wall Profiles to the wall with 40mm Screws (supplied). Do not over tighten the screws into the Wall Profiles as this will misshape the Wall Profile. Ensure the Wall Profiles stay completely vertical throughout this procedure using a Spirit Level.
 - **No sealant should be present between the Wall Profiles and the tiled walls vertically prior to screw fixing.**
5. Seal the gap between the Tray and Wall Profiles with a Bathroom Sealant (not supplied).
 - **Failure to carry out this procedure correctly can result in serious water damage and is not covered by the Guarantee.**

Step 3 - Fitting the Door and Side Panel

NOTE: Please use your Door Fitting Instructions in conjunction with these Instructions.

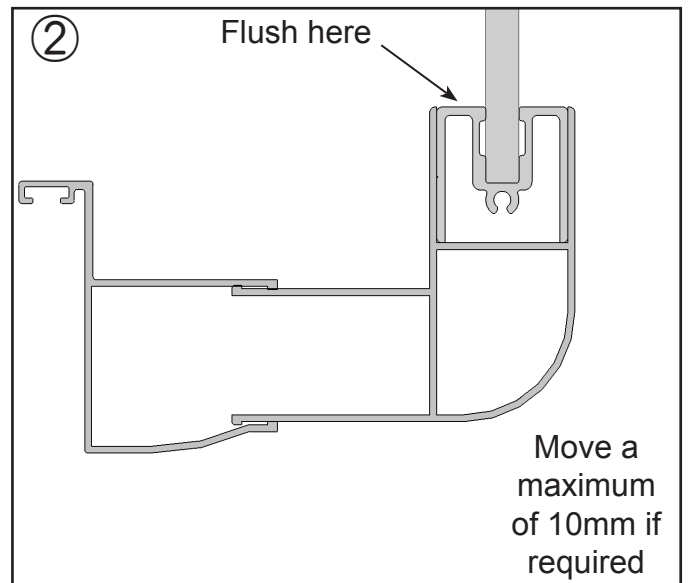
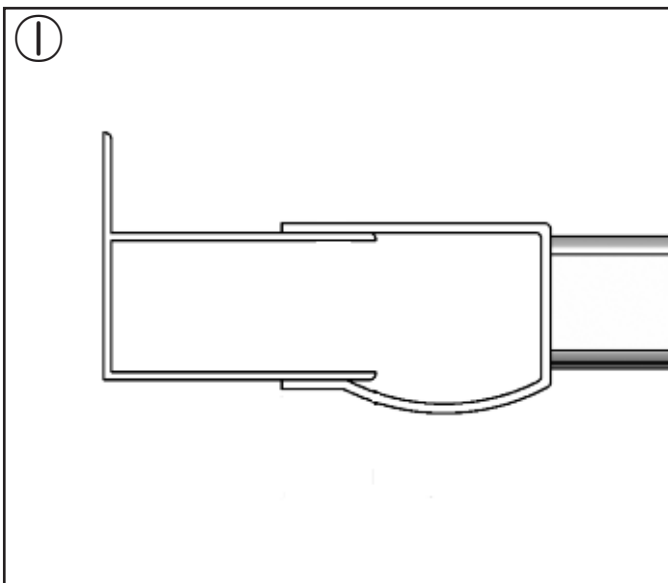
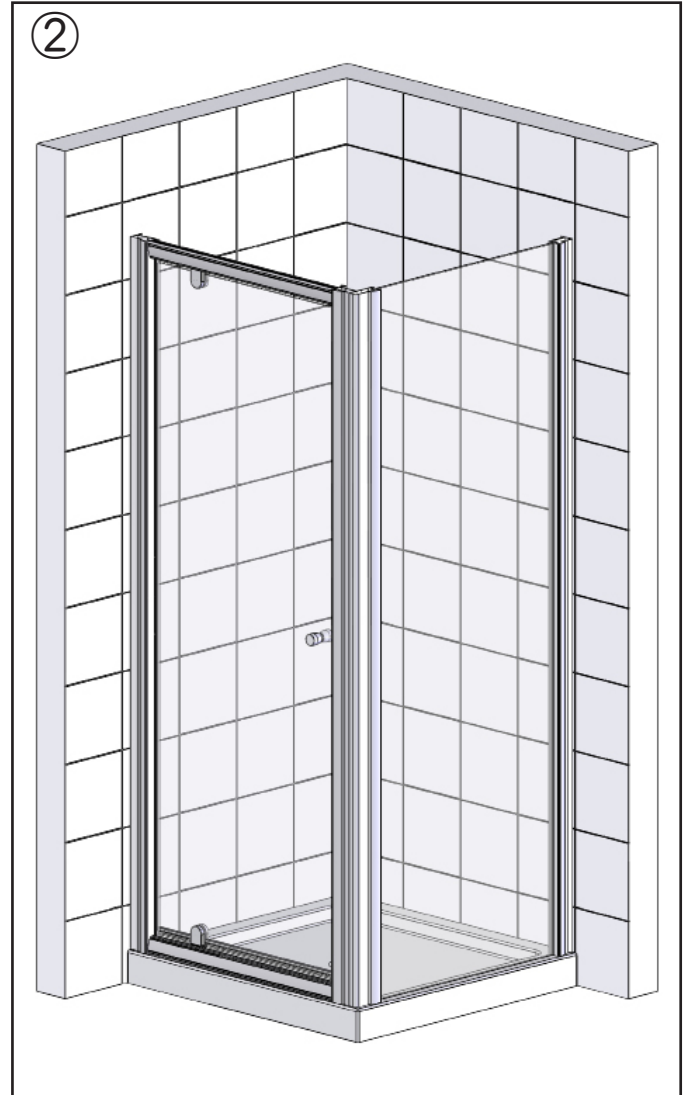
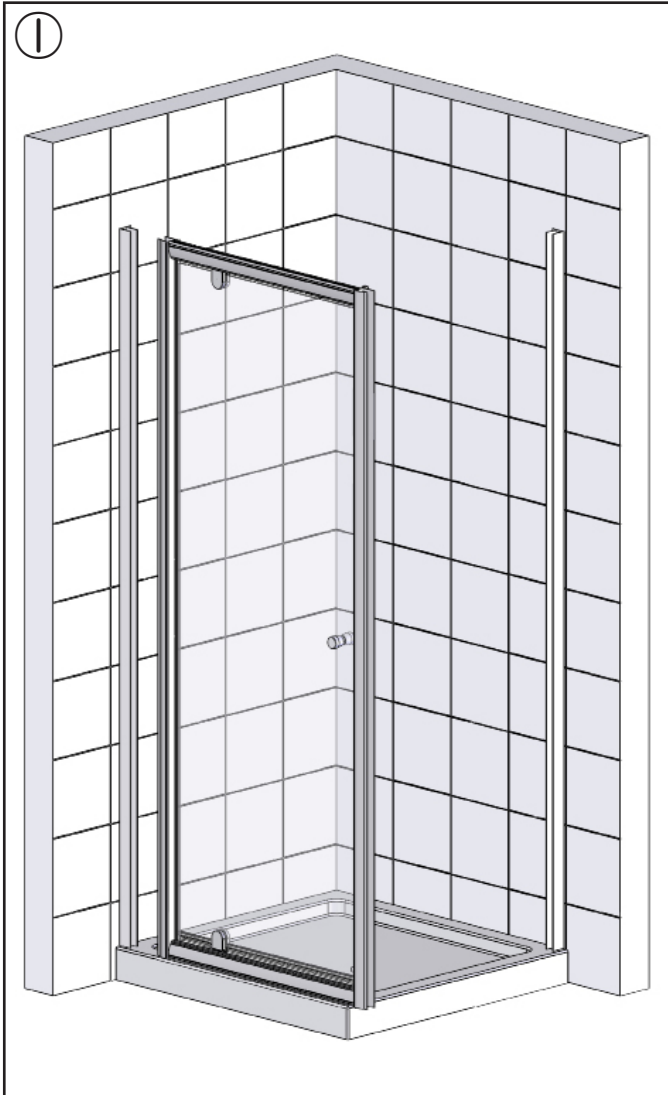

1. Lift the Door onto the Tray and locate fully over the 1st Wall Profile.
 - **NOTE:** The door should always pivot / hinge from the wall.
2. Lift the Side Panel onto the Tray and locate fully over the 2nd Wall Profile, then locate the Corner Post inside the Door Profile and over the Panel Profile. The Corner Post is intended to be flush with the Panel Profile but can if required be moved by a maximum of 10mm if you require more adjustment.
 - **NOTE:** If you choose to move the Corner Post then the Cover Cap will not fully cover the top.

Step 4 - Drilling and Fixing the Enclosure

NOTE: This part of the installation requires 2 people.

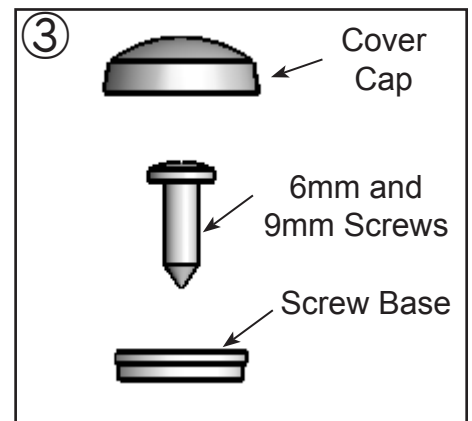
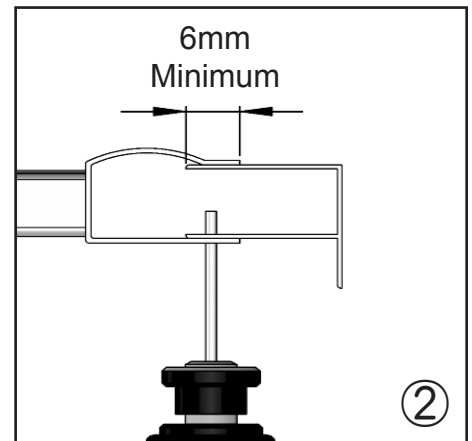
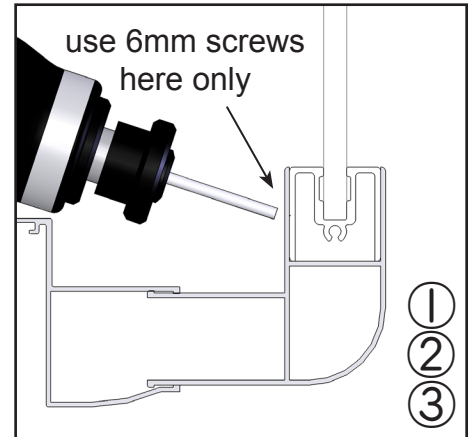
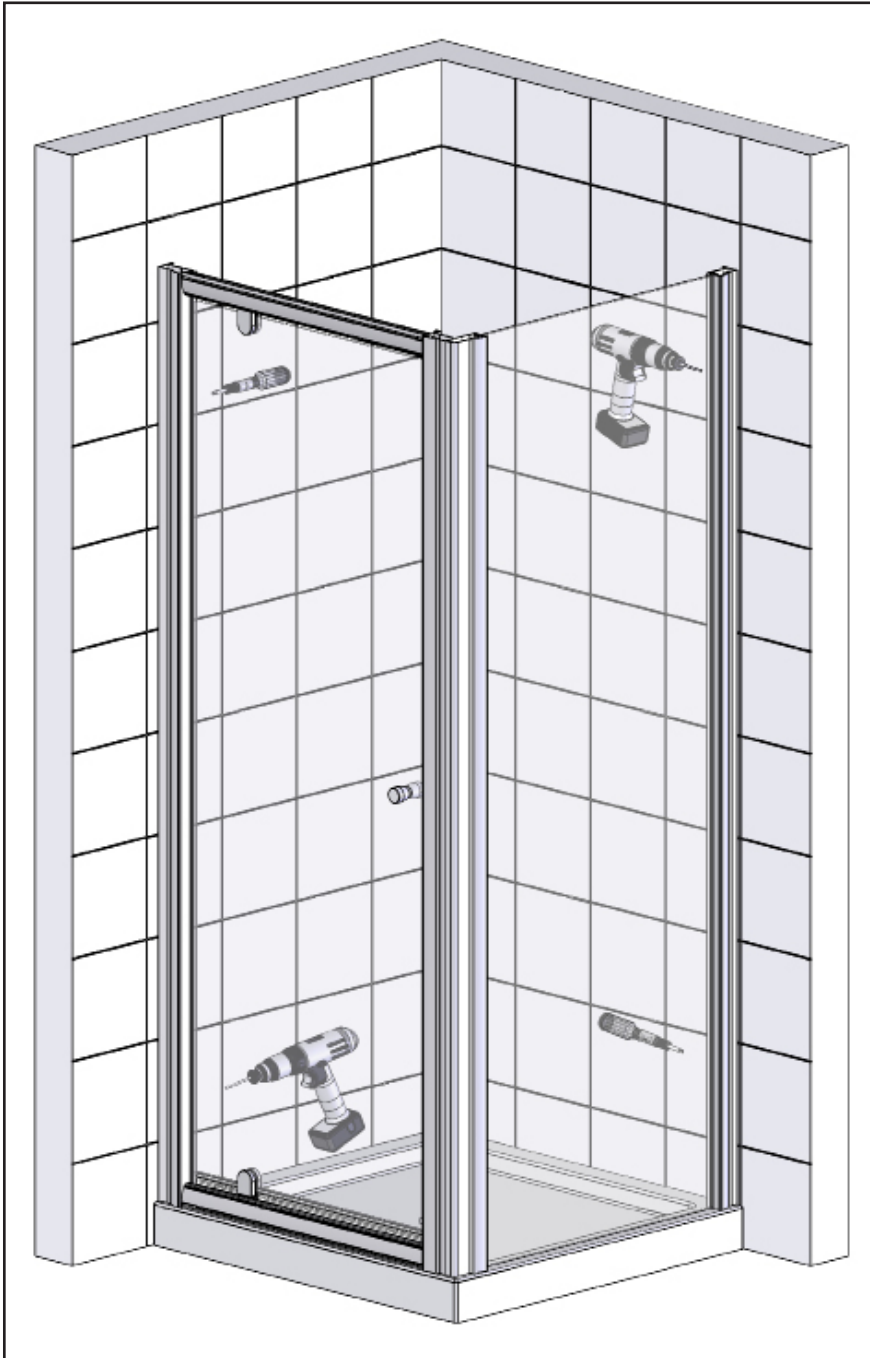

1. Adjust the Corner Post and Panel so that the Door is parallel with the tray. To achieve this, slightly ease the Side Panel away from the Wall Profile. For further adjustment ease the Corner Post away from the Side Panel (see the Note in stage 2 of Step 3).
2. The Wall Profile and Corner Post holding the Side Panel must overlap the Side Panel by at least 6mm. Inside the enclosure drill three 2.5mm holes into the Wall Profile and Corner Post (you may need to drill the Corner Post at a slight angle). The three holes should be drilled approximately 50mm from top and bottom and one in the centre. During this procedure ensure the Door and Panel remains aligned with the Tray.
 - **Note: Use a Spirit Level to keep the Side Panel and Corner Post completely vertical in this procedure.**
3. Place Screw Bases onto the 6mm and 9mm screws. Use the 6mm Screws to secure the Corner Post to the Side Panel and use the 9mm Screws to secure the Panel to the Wall Profile.
4. With the Door central between the Wall Profile and Corner Post drill three 2.5mm holes as per the Door instructions.
 - **Note: When following your Door Instructions, one Wall Profile is now replaced with the Corner Post.**

Step 5 - Sealing

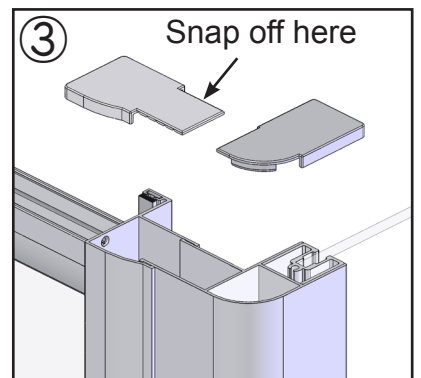
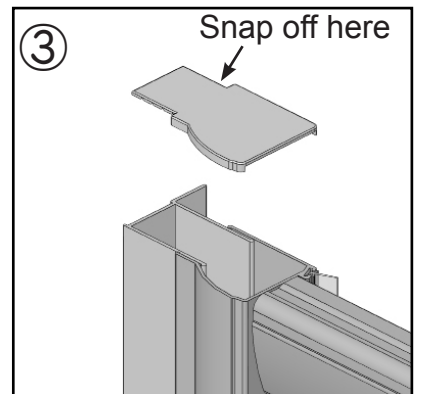
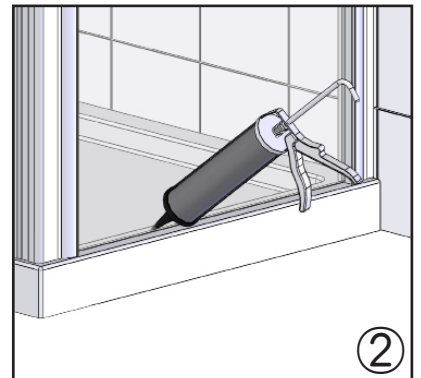
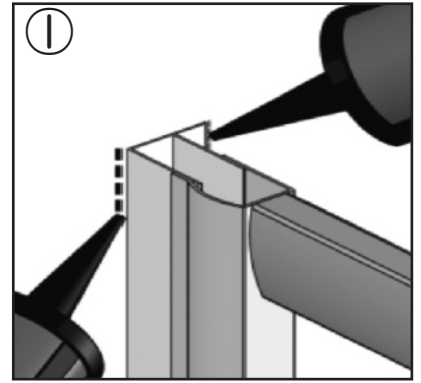
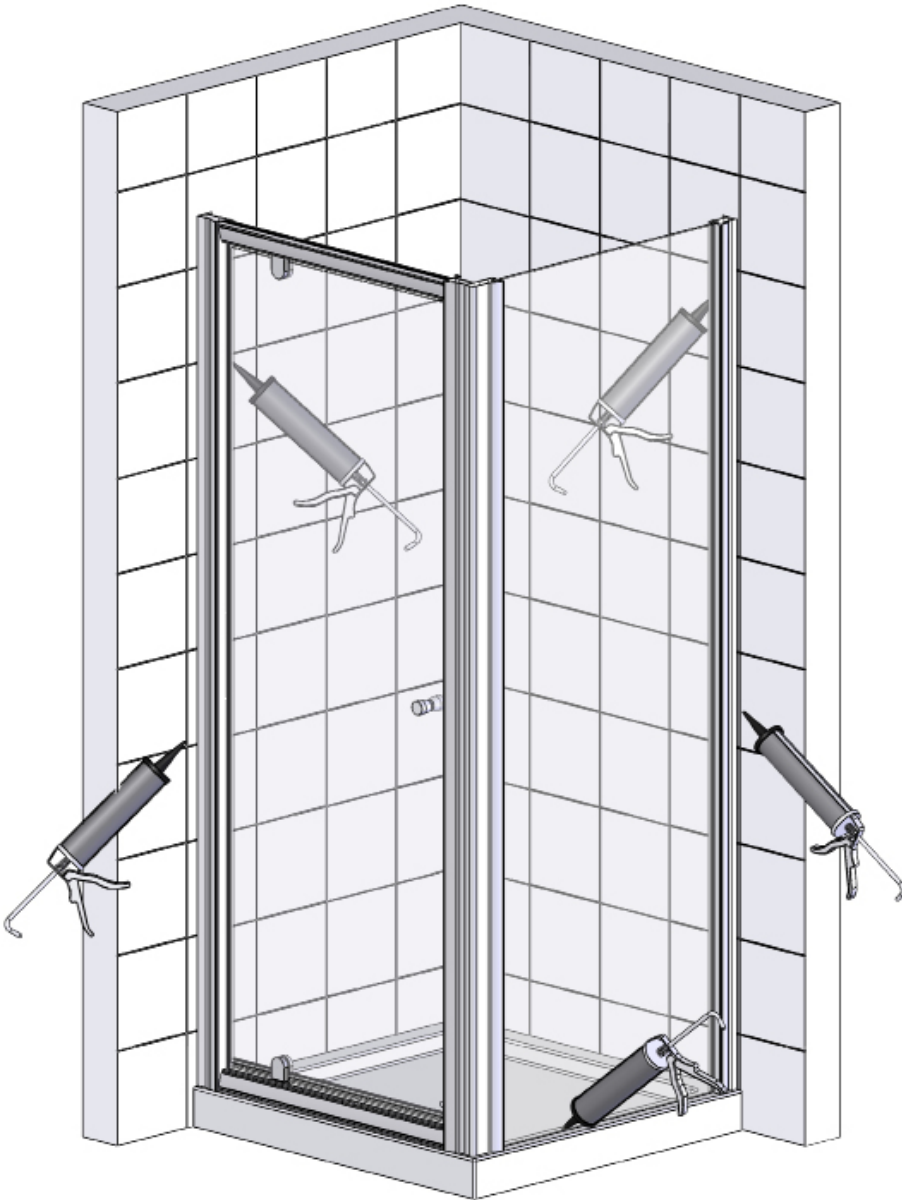

1. Seal both Wall Profiles vertically, both internally and externally where they meet the tiles.
2. Seal the base of the Door and Panel to the top of the tray from wall to wall on the outside only.
 - **IMPORTANT: Failure to carry out stages 1 and 2 may result in serious water damage and is not covered under the terms of the guarantee.**
 - **DO NOT seal the base of the product to the inside, failure to comply may result in the product leaking.**
 - **Allow 24 hours for the sealant to fully cure prior to using the shower.**
3. The Top Caps with grooves and can be shortened by snapping off at these points (adding a small amount of sealant will help keep them in place).

Spare Parts

If you need to replace any damaged parts please see illustration below for parts list then call Customer Relations on 01325 328033

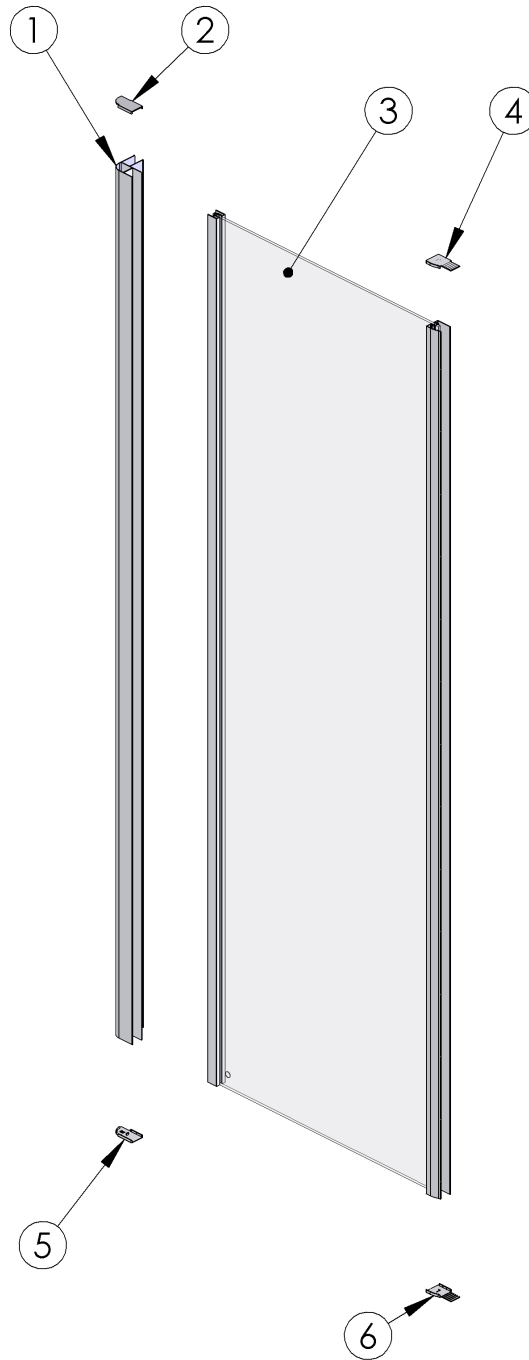

Part No.	Description	Q'ty	Part No.	Description	Q'ty	Part No.	Description	Q'ty
1	Corner Post	1	11			21		
2	Corner Cap (Left Hand)	1	12			22		
3	Panel Assembly	1	13			23		
4	Top Cap (Right Hand)	1	14			24		
5	Corner Cap (Right Hand)	1	15			25		
6	Top Cap (Left Hand)	1	16					
7			17					
8			18					
9			19					
10			20					

TROUBLE SHOOTING GUIDE

Problem	Solution
Leaking	<ol style="list-style-type: none">1. Check that the inside gap between the Tray and Wall profiles has been sealed correctly.2. Ensure the tray is sealed along the tiled walls prior to installation.3. If the inside joint between the enclosure and the tray top is sealed, this will cause leakage - sealant must be removed.4. Ensure the wall profiles on the tiled walls are sealed both vertically inside and outside.5. Ensure the joint between the enclosure and tray top is sealed. <p>Important: This enclosure should be water tested conforming to BS EN 14428</p>
Enclosure Alignment on the Tray	<ol style="list-style-type: none">1. Is the enclosure fitted onto a tiled wall?2. Are the Wall Profiles fitted 10mm from the outside of the tray?3. Are the wall profiles completely vertical?

Some important information to help you Maintain your product.

The following information is all you need to keep your product looking new.

Clean your product using a mild detergent diluted in water and then polished off using a soft cloth.

If you live in a hard water area, periodically clean your product using a 50/50 solution of white vinegar and water. The solution should be left on the enclosure for approximately 5 minutes then rinsed off using warm water. This method of cleaning should remove lime scale residue.

Simple Maintenance

Our products are generally maintenance free, however it may be necessary to lubricate wheel assemblies and other moving parts from time to time.

It is strongly recommended that a quality silicone spray is used.

A list of Don't's:

1. Don't use acidic based products which are unsuitable for cleaning enamel surfaces.
2. Don't use abrasive cleaners or cleaners using bleach or solvents, these products will adversely affect the finish of the aluminium profiles.
3. Don't use scouring pads, powder or any sharp instruments when cleaning the enclosure.

Should you experience any problems during installation please refer to the Trouble Shooting Guide or contact Customer Relations on:

+44 (0) 1325 328033

To enable customer relations to provide you with an excellent level of service it is important that you quote your product Code and Reference Number - these can be found on the Guarantee card.