

# Homac 400 UP Macerator

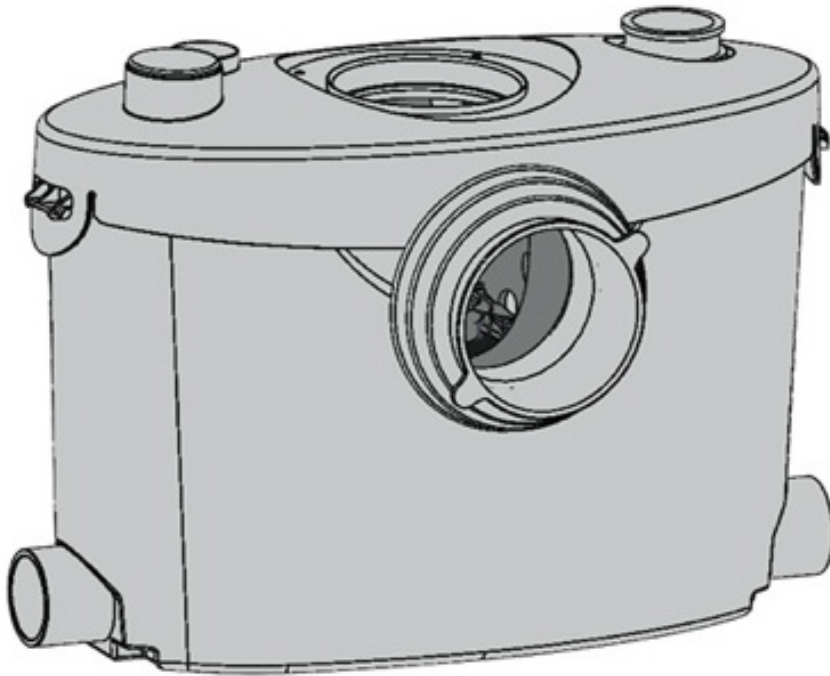

**INSTALLATION  
INSTRUCTIONS**

**Please follow these care instructions to ensure your product retains it's high quality finish and please retain this leaflet for future reference.**

Power:	400w	Voltage:	220~240V /50Hz
Horizontal Discharge:	80m	Vertical Discharge:	8m
Max Temp:	75°C (90°C in 4hrs)	Thermal Protection:	100°C
Max Flow Rate:	145L/Min	IP Rate:	IPX4

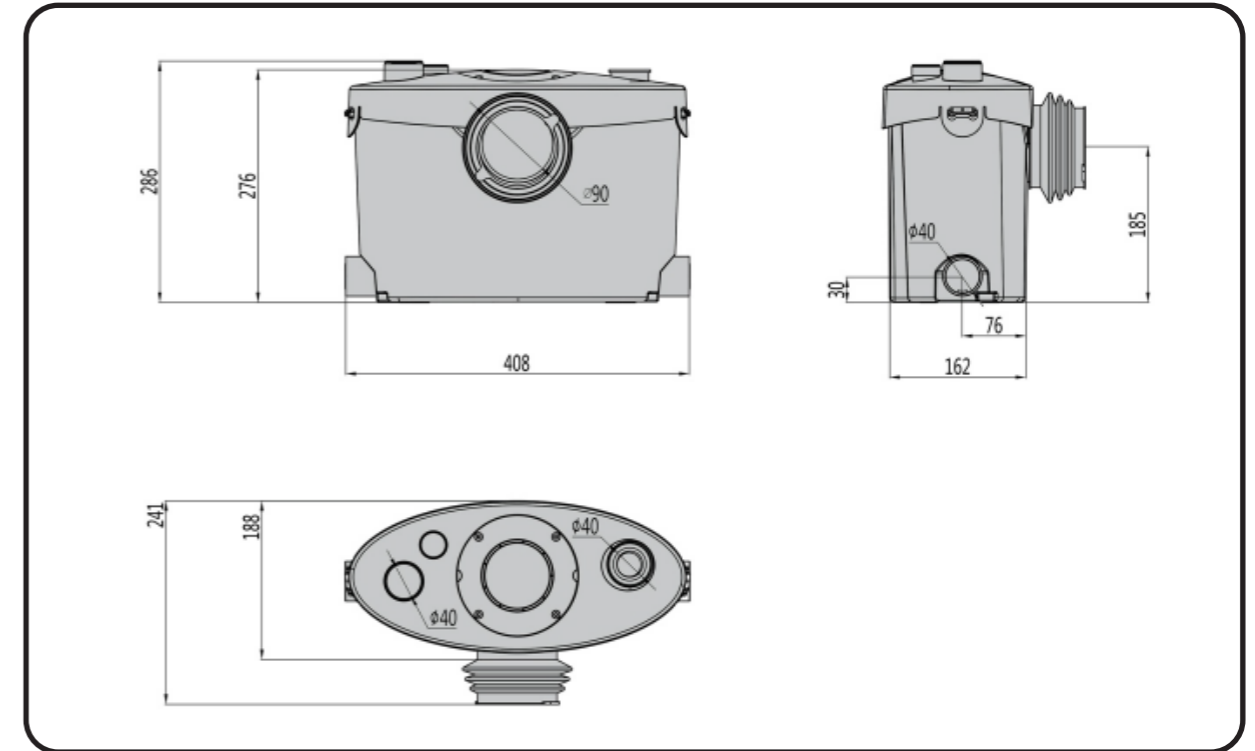

1	Inlet for Toilet Ø100mm	2	Inlet Ø40mm
3	Inlet Ø40mm	4	Inlet 40mm(Optional)
5	Outlet 23/28/32/44mm	6	Air-Vent
7	Repair Panel		

**Included Accessories**

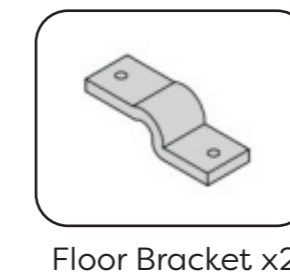
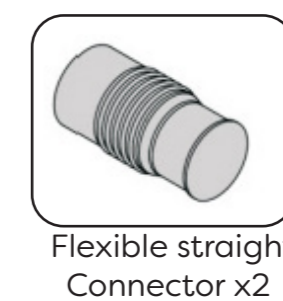
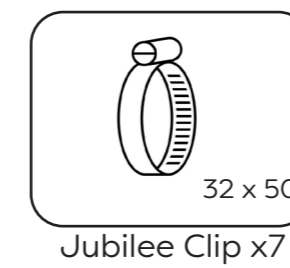
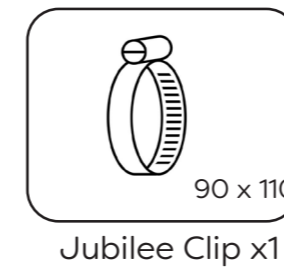

## **SAFETY INSTRUCTIONS**

### **Prior to installation**

- Ensure the entire contents of this instruction manual are read.
- Ensure the package contains all component parts listed in this instruction manual.
- Ensure the two check valves stored inside the rubber chamber of the appliance are removed.
- Ensure all packaging material is removed and disposed of correctly.

### **Installation**

- Electrical installation of the appliance must only be carried out by a qualified person.
- The appliance must be installed in accordance with the installation instructions specified in this document.
- Always ensure the macerator is connected to mains power before water enters the unit.

### **Prior to use**

- Before using the macerator, clean water must be flushed through the appliance several times. This will ensure the macerator is correctly installed.

### **Daily use**

- The appliance is suitable for domestic, indoor use only.
- The appliance is suitable for the discharge of domestic faecal matter, waste water and toilet paper only. Failure to comply with this will invalidate the warranty.
- Products not to be discharged using the appliance include but are not exclusive to: kitchen towels, wet wipes, cotton wool, condoms and sanitary towels.

### **Servicing and maintenance**

- Before servicing the appliance, always ensure the electrical supply is fully disconnected.
- Troubleshooting, maintenance and servicing of the appliance must only be carried out by a person who is competent to do so.
- To maintain optimum performance, it is recommended that the appliance is serviced and cleaned at least once every 6 months.
- For hygiene reasons, rubber gloves should be worn at all times when servicing the appliance.

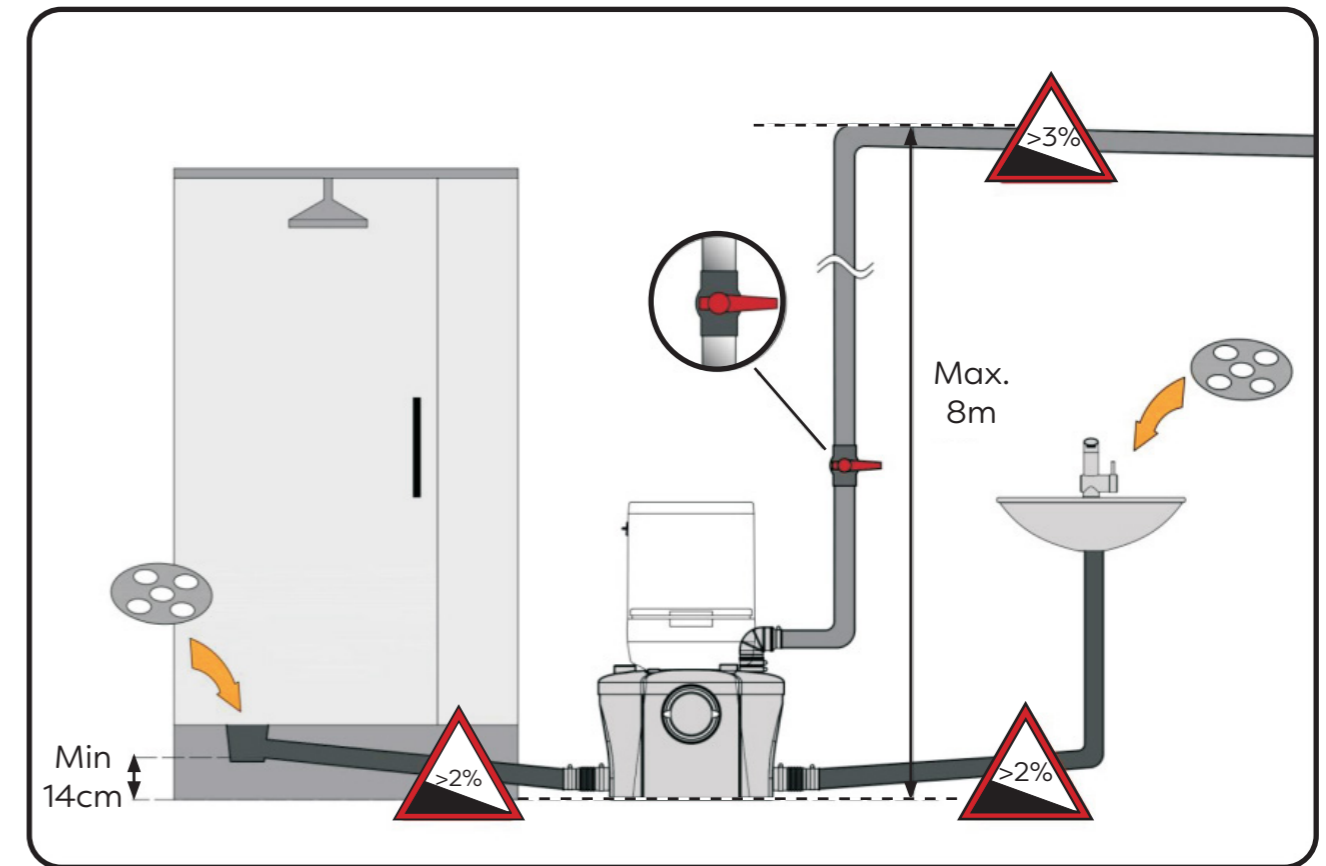

### **Connection**

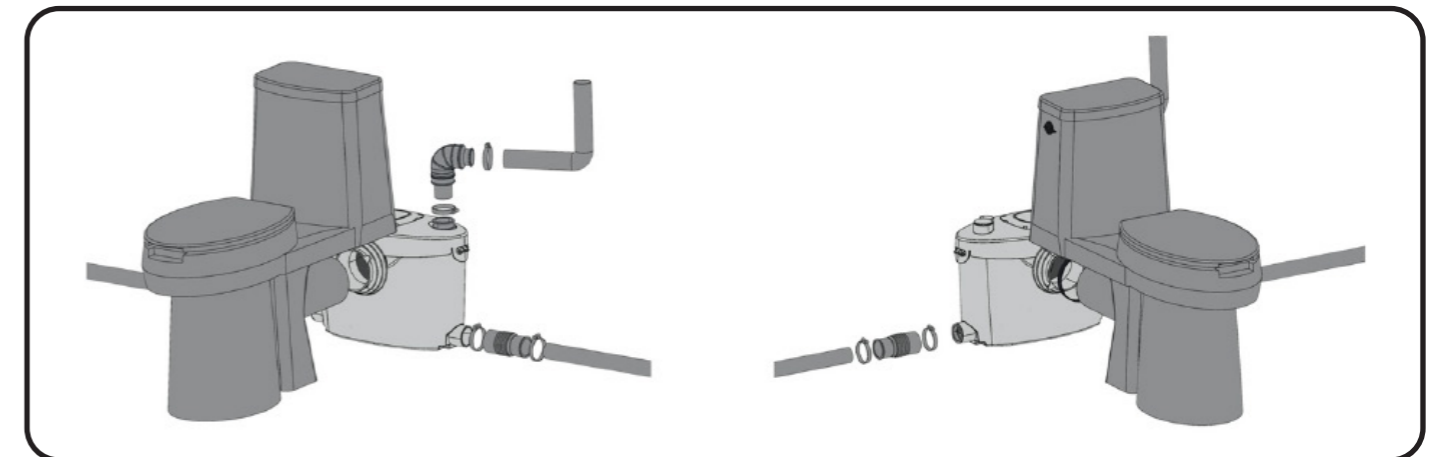

### **Optional inlet for additional equipment**

Please see the attached images if additional equipment is to be attached to the unit.

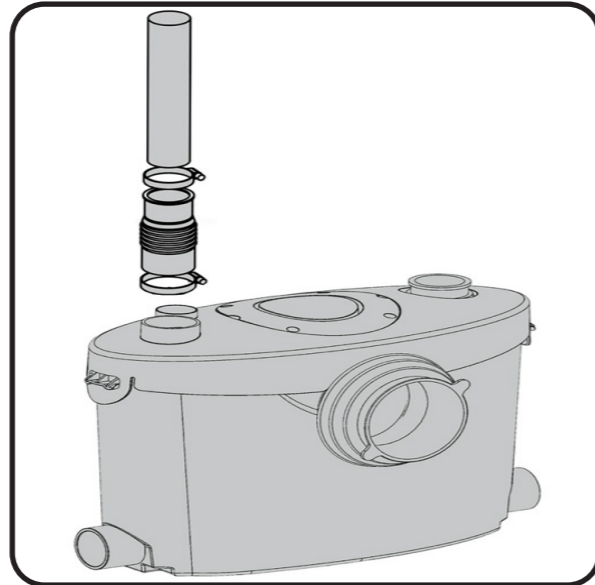
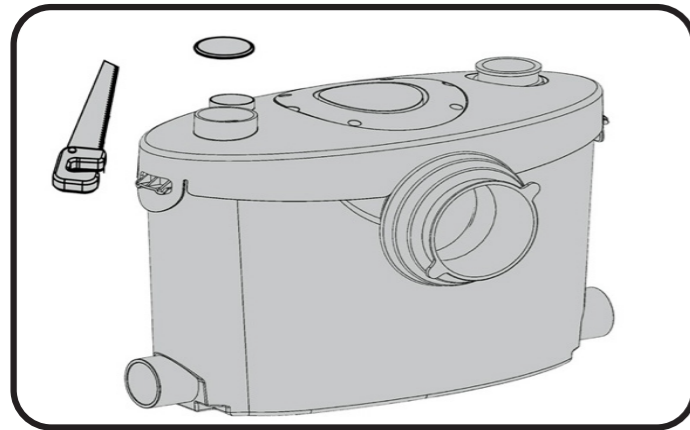

### **Inlet covers**

Please ensure that any unused inlets are covered before operation

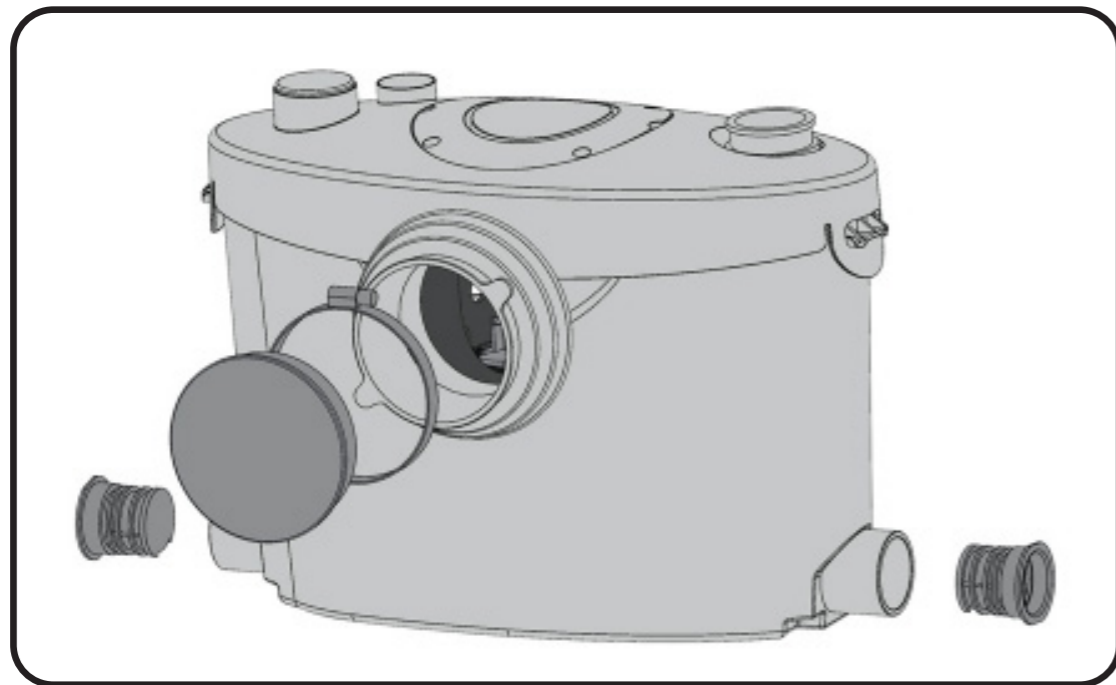

### **Attaching floor brackets**

Please attach the floor brackets as per the below images.

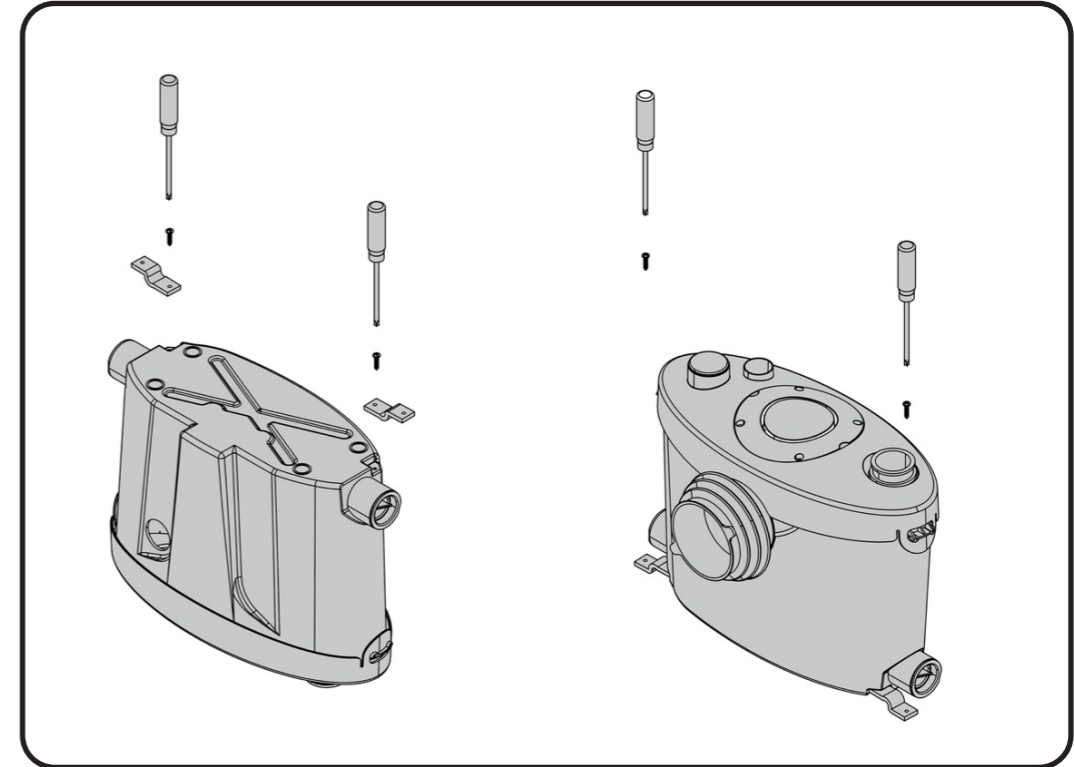

### **Flexible outlet ( check valve)**

Insert the flexible outlet and secure using a jubilee clip. When secure, cut the pipe to the required length.

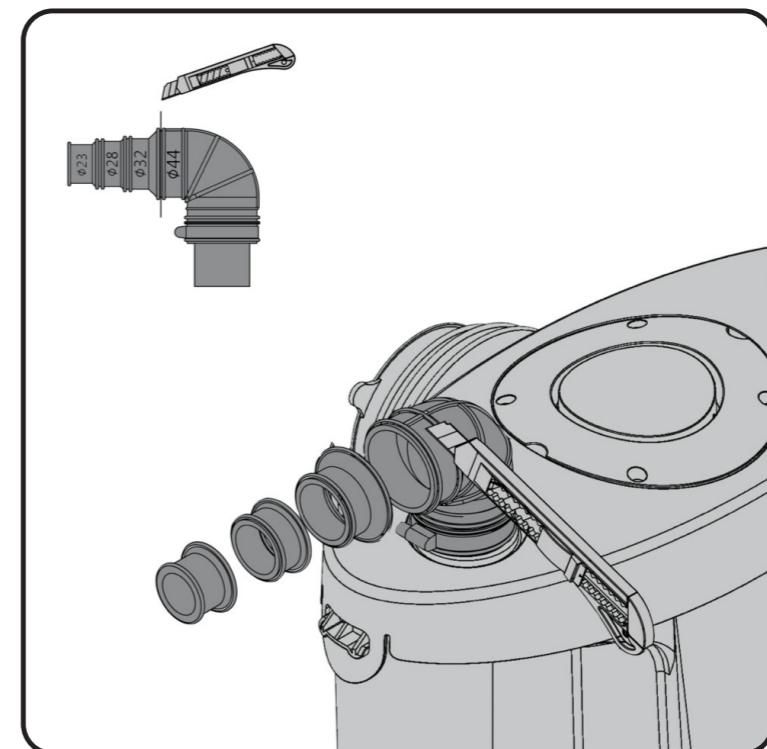

## Pumping Head

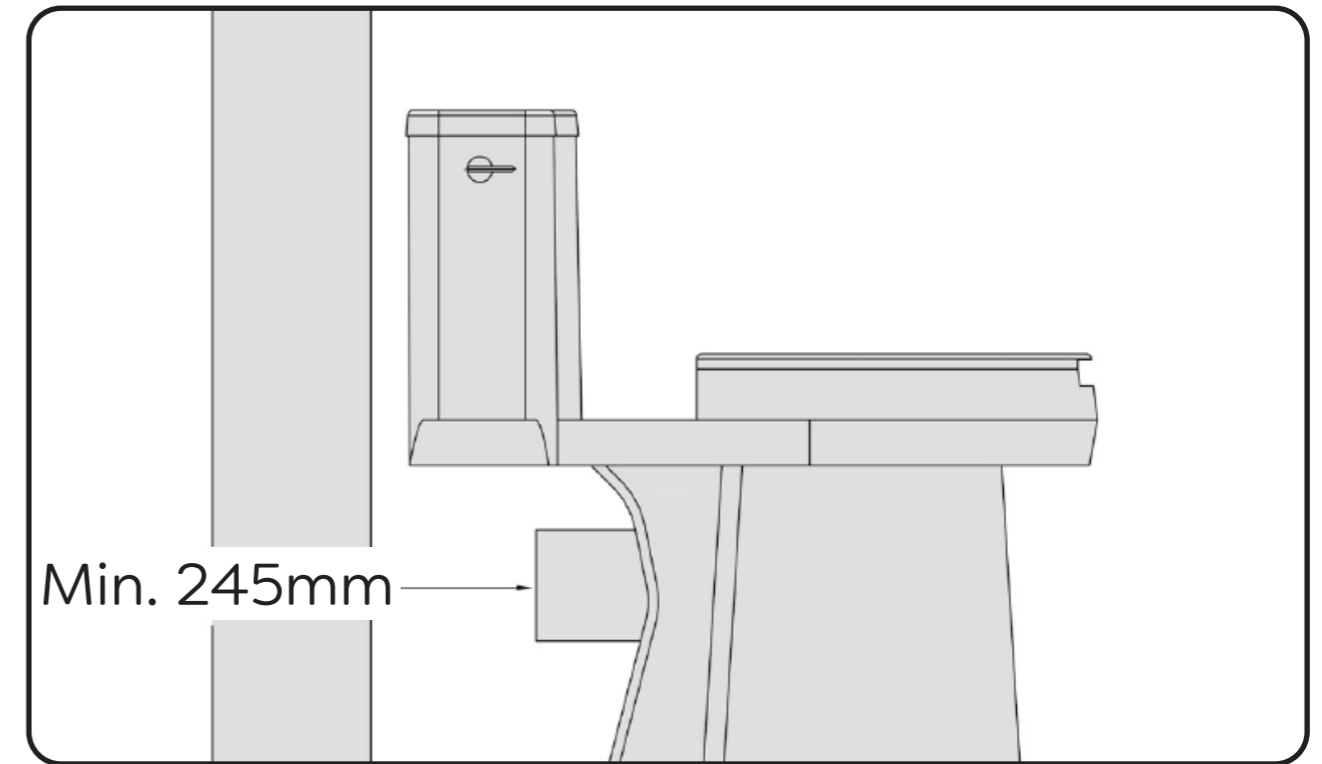
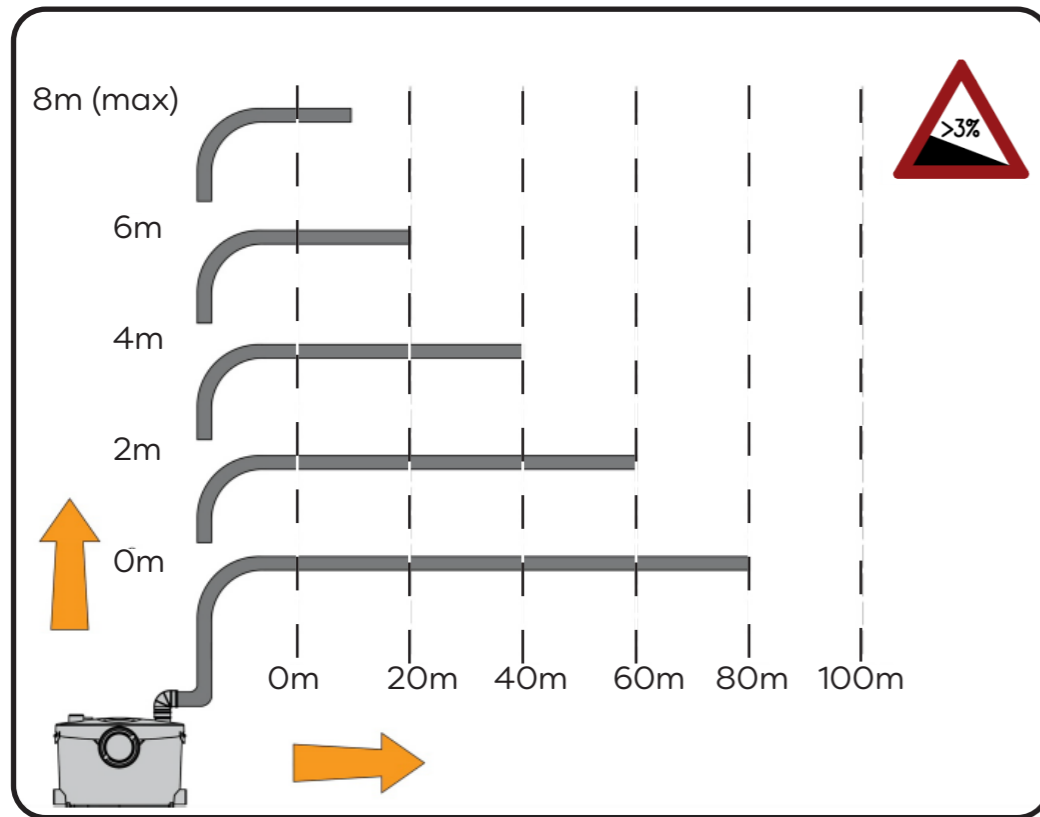

## Flow Rate

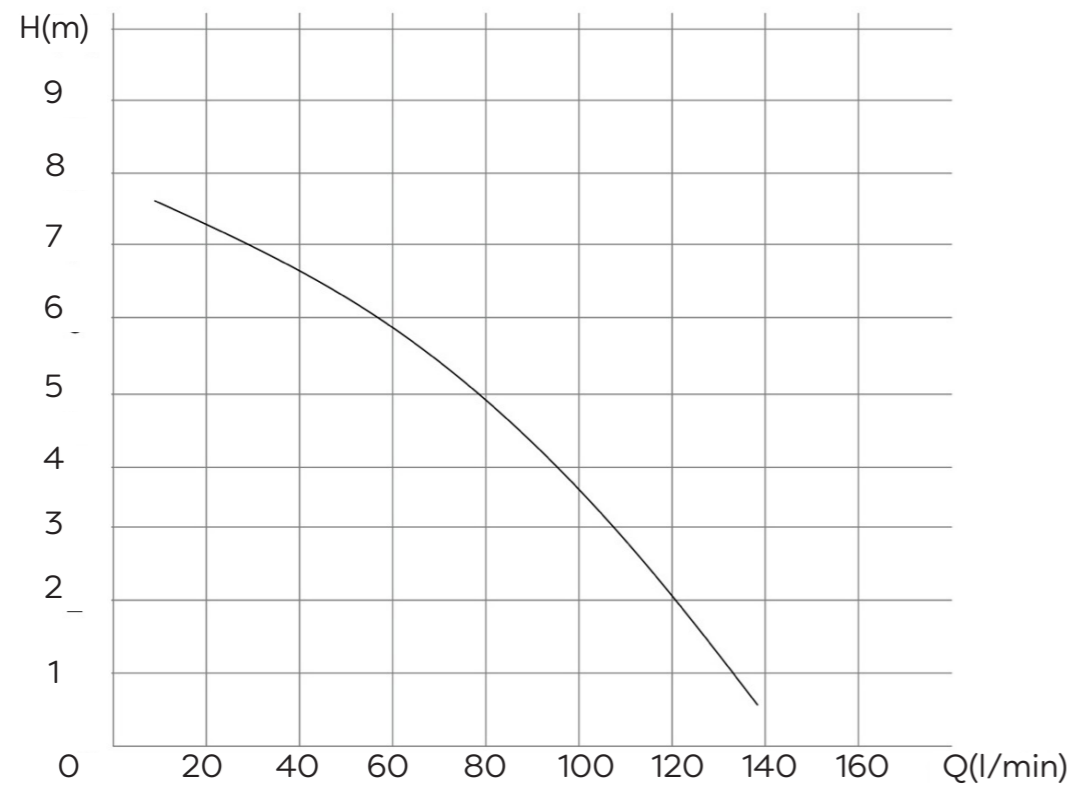

## WARNING!!

- The appliance is only ready for use after installation
- The appliance must be supplied through a residual current device (RCD) having a rated residual operating current not exceeding 30mA
- If the supply cord is damaged, it must be replaced by the manufacturer or its service agent or a similarly qualified person in order to avoid hazard
- Children should be supervised to ensure that they do not play with the appliance
- This device is for domestic use only

In order to ensure total satisfaction with your appliance for many years, only toilet waste, water and paper should be discharged using the waste pump for toilet. Discharge of any other materials than those mentioned will invalidate the warranty.



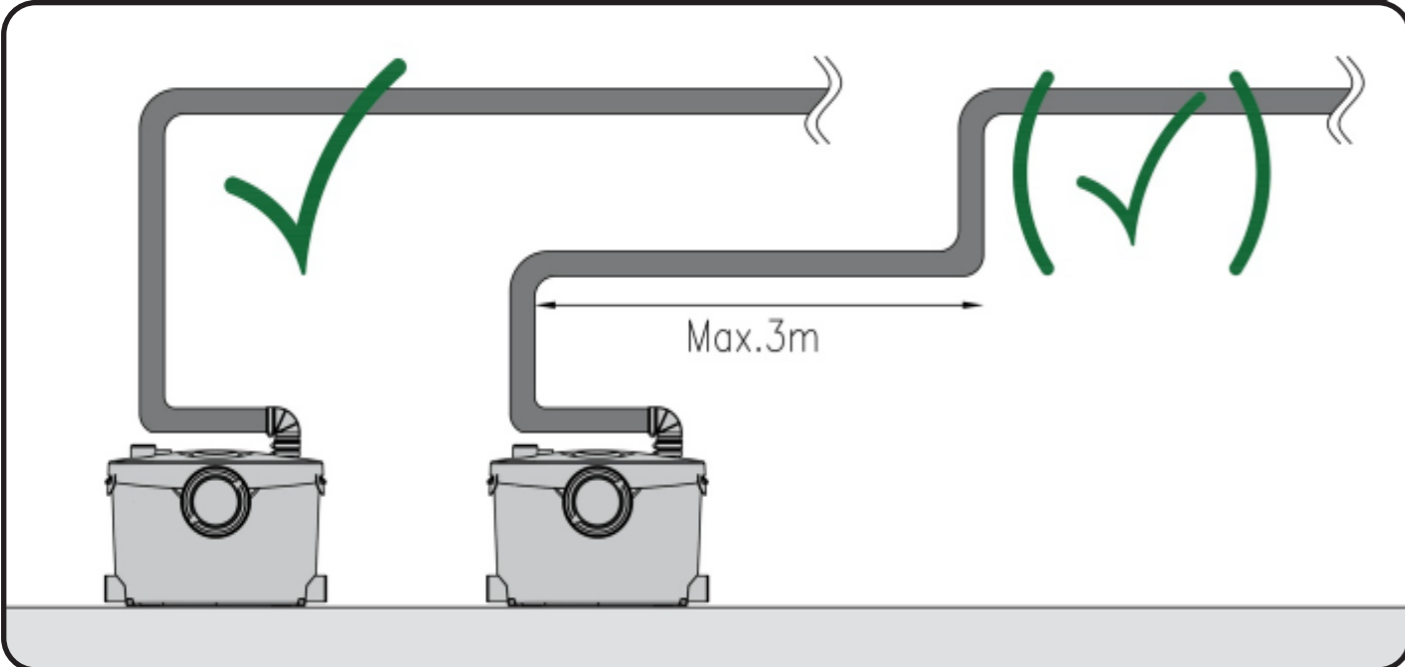
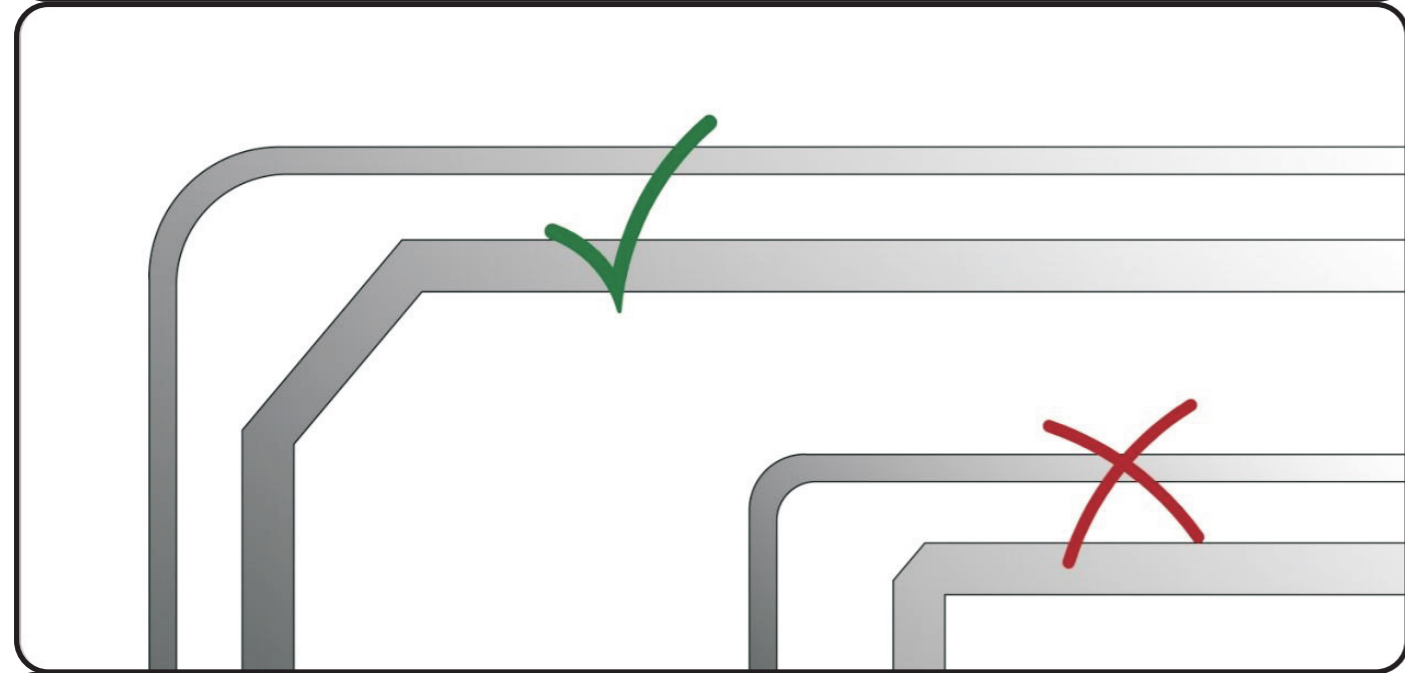
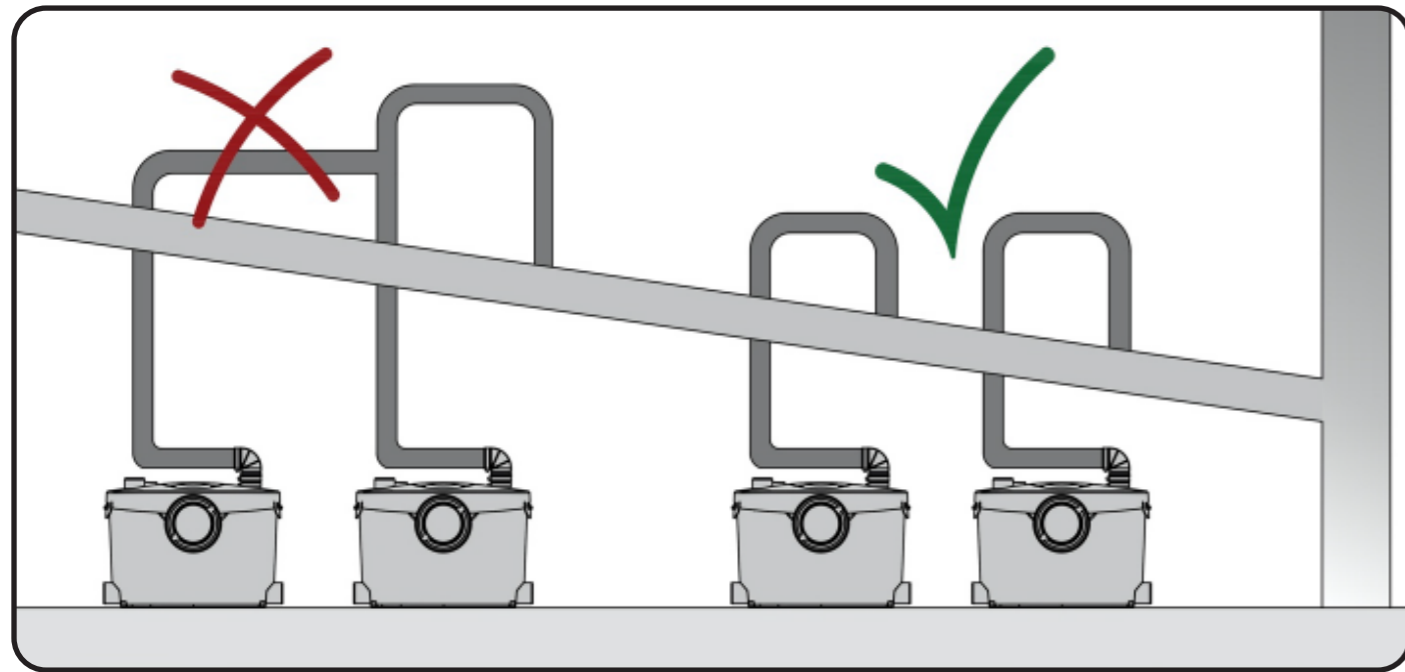

## Installation

- Place some silicone or liquid soap on the toilet spigot
- Fit the collar supplied on the bowl outlet
- Pull the flexible sleeve over the pan spigot
- Position the jubilee clip over the edge of the flexible sleeve, and tighten with a screwdriver
- Once the appliance has been positioned, fix it to the floor using the 2 screws supplied. (If using the two floor fixing lugs, secure them to the floor before positioning the unit.)

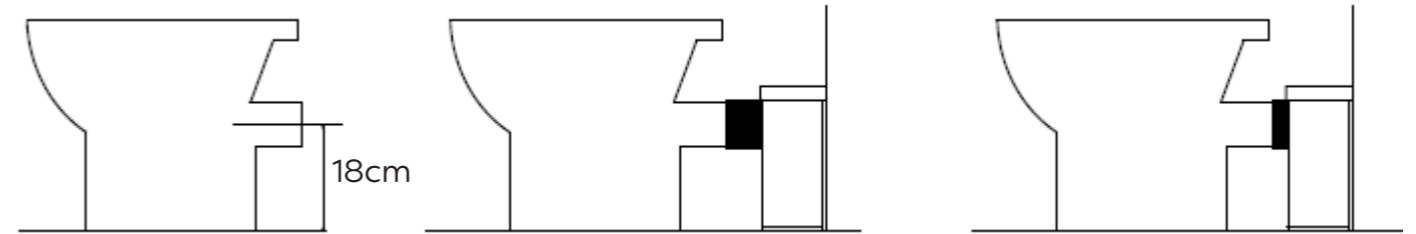

## WARNING !!!

There should be no dripping of water from the toilet cistern or any other sanitary appliances. If there is, this will cause the unit to activate repeatedly as it pumps the water away.

### Connection of discharge pipework

Insert the discharge elbow into the rubber discharge pipe, turn to the desired direction and secure with the metal jubilee clip provided (36mm-50mm). Then connect the hose to it using the 20mm-32mm metal jubilee clip, making sure the hose is not kinked. A 22mm-32mm plastic reducer is supplied if 32mm discharge pipework is to be installed.

### Technical advice for discharge pipework

- Horizontal pipe runs must have a minimum fall of 1:200 (5mm per metre) to the soil stack,
- If a vertical lift is required, it must be made before the horizontal run at the start of the piperun
- We would recommend that a drain-off point is installed to allow the discharge pipework to be drained down before any service work
- If the discharge pipework runs to a level considerably lower than the unit, the resultant syphoning effect can suck out the water seal in the unit. Fitting an air admittance valve (BBA approved) at the high point of the pipe run will overcome this problem,
- The discharge pipework must be connected to the soil stack using an appropriate strap on boss

Ensure all external pipework is adequately lagged to avoid the possibility of freezing.

**N.B.:** Any elbow on the discharge pipe of the unit will create friction loss (roughly 50 cm per elbow to be deducted from the vertical pumping spec.)

Always use smooth bends (OR 2 X 45 degree bends together) and not 90 degree elbows.

Once electrical and pipe connections have been made, flush the toilet once. The motor should run from 5 to 10 seconds to clear the waste (depending on the height of the pipe run). If it runs for more than 20 seconds, check that the pipework is clear, and that the discharge hose is not kinked.

Flush the toilet checking that all seals, and connections are watertight. Check both the discharge pipework from the unit and the other sanitary appliances connections.

**WARNING !!!**

If away for a long periods (eg holidays) we recommend that you turn off the water supply to the WC served by the unit.

Toilet connected to this unit can be used like any normal toilet, and requires minimum maintenance. The unit will operate automatically as soon as the required level of water enters the case. The motor thermal protector will operated once the motor is overheat, unplug the plug from the socket-outlet, then plug again, the appliance will work normal after waiting about 30-60minutes.

**WARNING !!!**

Only the disposal of toilet papers, faecal matter, and waste water will be under guarantee. Any damage due to foreign bodies such as cotton, condoms, sanitary towels, wet wipes, food, hair, metal, wood or plastic objects, will not be under guarantee. Solvents, acids and other chemicals can also cause damage to the unit, and will invalidate the guarantee.