

Product code
T273202

Verse Bath Filler

Installation & aftercare instructions

Please retain for future reference



ROPER RHODES

Customer Service

Tel: 01225 303 900 Fax: 01225 448 877

Email: sales@roperrhodes.co.uk

www.roperrhodes.co.uk

Roper Rhodes Limited

Brassmill Lane Trading Estate, Bath, BA1 3JF

Aftercare Instructions

Whilst this item has a high quality durable finish, it should nevertheless be treated with care. Surfaces should be cleaned using only a soft damp cloth and clean water & dried using a soft cotton cloth. Bath cleaning products, even non-scratch ones could damage the finished surface.

10 Year Guarantee

We have complete confidence in this Roper Rhodes product and as such it is offered with a 10-year guarantee against defects in manufacture. This product must be fitted by a competent installer. If in doubt seek advice from a qualified professional. The guarantee requires that this product be used in the manner for which it was intended and that it is installed & maintained in accordance with the fitting instructions and local water bylaws. The guarantee covers products in domestic use only. The guarantee is invalidated should the product be damaged by water borne debris. Make sure that supply pipes are clear of any debris prior to installation, this is particularly important on new plumbing installations. In the unlikely event that this product should fail during the guarantee period we will either replace the faulty part or the complete unit as appropriate. Tap valves are subject to a 1-year guarantee. This guarantee covers damage against reasonable wear and tear in use only. It does not cover damage incurred during installation, misuse or inappropriate maintenance. We recommend that the valve is regularly cleaned in hard water areas to prevent lime scale build-up. Replacement valves are available to purchase by contacting the Roper Rhodes Customer Service team. Failure to follow the terms outlined above will invalidate this guarantee. Proof of purchase will be required to validate any guarantee claims.

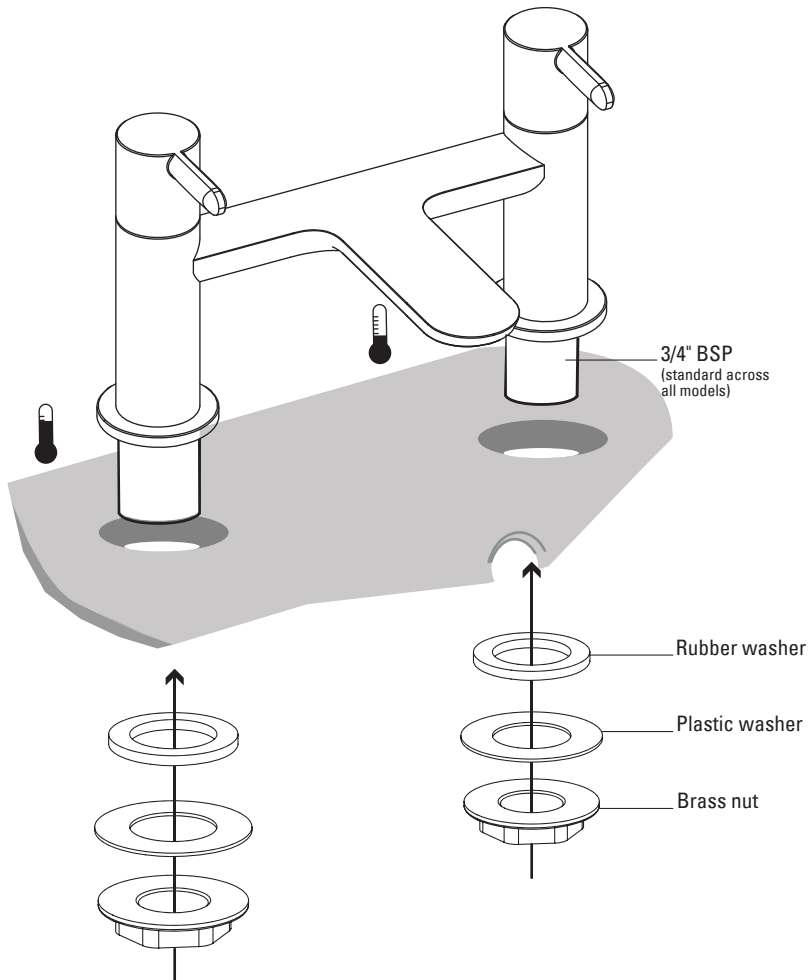

Installation Procedure:

1. Prior to installation flush out the pipe work to remove debris & then ensure that the water supply is turned off.
2. Refer to diagram & check that all components are present.
3. Fit the mixer to the bath using the brass nuts and the washers provided as indicated in the diagram.
4. Connect the hot & cold water supplies. The hot supply should always be connected to the left hand side.
- 5 Fully open mixer on both hot & cold sides & allow water to run for approximately one minute to further flush the system.
6. Check all connections for leaks.