

Pleate note: This template is intended for dimensional reference and will not print to scale.

520

Stage 1. Worktop Cutting Instructions

Before you begin, fit the worktop to the base unit.

1. Cut out the Worktop and Fascia templates along the black outline.
2. Measure the worktop overhang from the fascia front on the unit, 'distance X' (see Fig. 1)
3. Mark this distance on the Worktop Overhang area of the Worktop Template using the pre printed lines as a guide. Note, if you are using a Roper Rhodes laminate or solid surface worktop the overhang distance (12mm) has been pre marked. Mark a line and lightly score along it then fold along the scored line.
4. Find the centre of the base unit the basin is to sit above and using masking tape and a pencil mark this position on the fascia just below the worktop.
5. Lay the cut out Worktop Template on the worktop aligning the centre line with the centre of the base unit marked in the previous step (See Fig. 2).
6. Using masking tape mask beneath the template edges on the worktop (See Fig. 3). Then trace around the template outline onto the masking tape.
7. Detach the worktop from the unit and secure appropriately on a cutting bench before cutting along the traced outline.
8. Drop the basin into the slot on the worktop and find its central position then mark where the curved sides meet the worktop front (See Fig. 4).
9. Continue this line on the top of the worktop by distance 'X' measured in step 2.
10. Cut the notch (See Fig. 5). Proceed to Stage 2. Fascia cutting instructions.

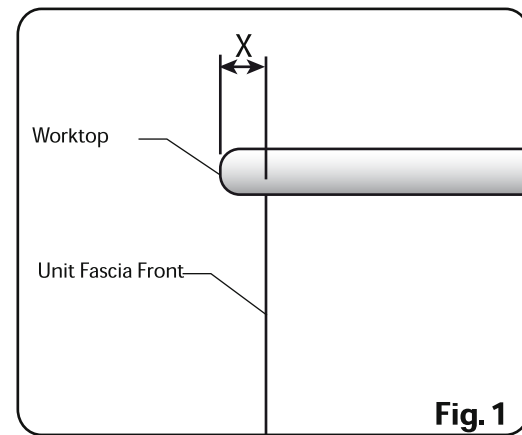

Fig. 1

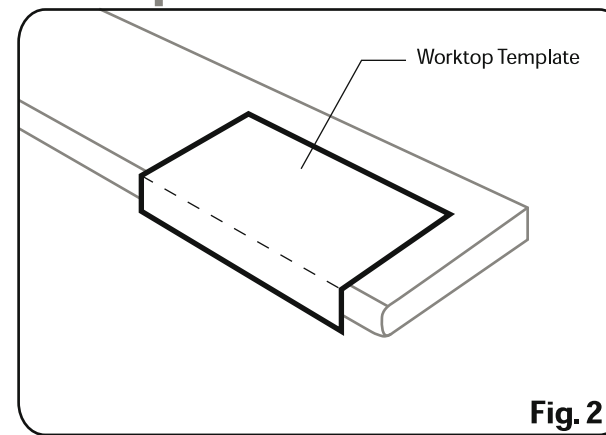

Fig. 2

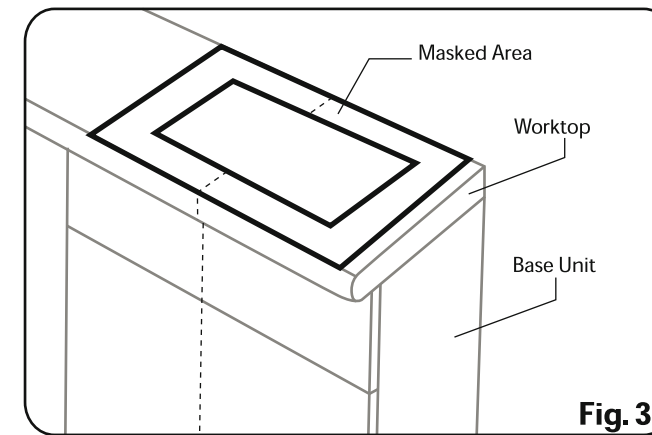

Fig. 3

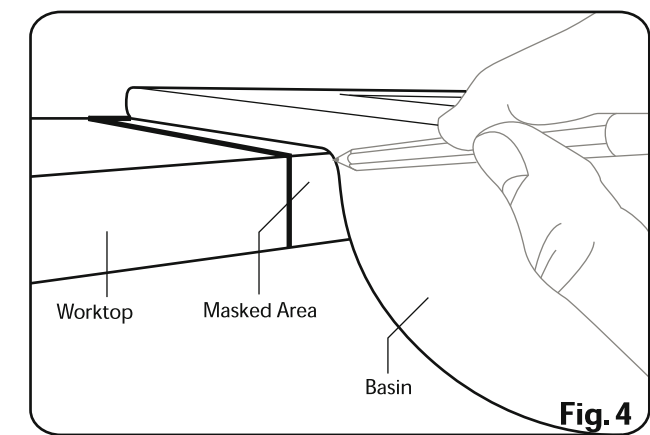

Fig. 4

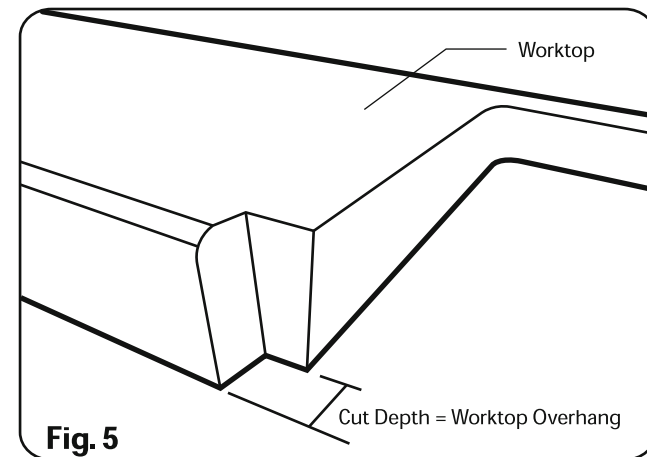

Fig. 5

Worktop Template

This template is designed to aid fitting a Roper Rhodes 560mm wide semi countertop basin

Stage 3. Basin Fitting Instructions

Before you begin it is recommended that you seal all the cut edges of the worktop and fascia with waterproof sealant (not supplied) to avoid water penetration.

1. Apply waterproof sealant (not supplied) to the rim of the basin and the area of the worktop where the two mate.
2. Place the basin (complete with tap and waste fittings) in position on the worktop and apply a firm pressure around all edges of the basin to achieve a good seal.
3. Remove excess sealant.
4. Allow the sealant to set for the recommended duration.

Unit Fascia Front

Worktop Overhang (distance 'X' in Fig.1)

Worktop Thickness

Stage 2. Fascia Cutting Instructions

Before you begin, detach the fascia from the base unit.

1. Measure the worktop thickness.
2. Mark this distance on the Worktop Thickness area of the Fascia Template using the pre printed lines as a guide. Note, if you are using a Roper Rhodes laminate or solid surface worktop the thicknesses of these have been pre marked. Mark a line and lightly score along it then fold along the scored line.
3. Find the centre of the fascia and using masking tape and a pencil mark this position.
4. Lay the cut out Fascia Template on the fascia aligning the centre line with the centre of the fascia marked in the previous step (See Fig. 6).
5. Using masking tape mask beneath the template edges on the fascia. Trace around the template outline onto the masking tape.
6. Secure the fascia appropriately on a cutting bench before cutting along the traced outline.
7. Reattach the fascia to the base unit. Proceed to Stage 3. Basin Fitting Instructions.

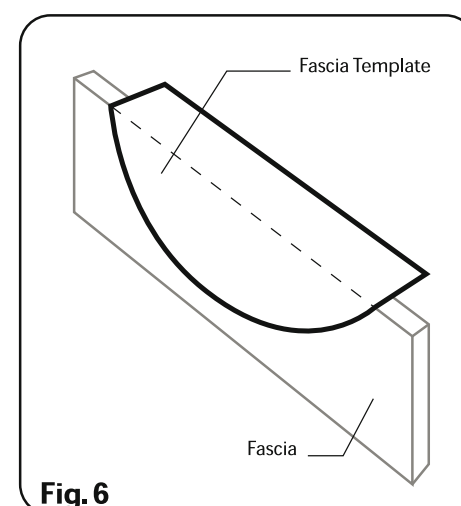

Fig. 6

Fascia Template

28 Roper Rhodes Laminate worktop
32 Roper Rhodes Solid Surface worktop

220

12 Overhang when using Roper Rhodes Fitted Furniture and worktops.

0
10
20
30

(dimensions in mm)

Line up with TOP edge of worktop

118

517