

Bifold Door

Instruction Manual

H2B



PO Box 125, Whitworth Avenue,
Aycliffe Business Park,
Co Durham DL5 6WX

12

EN 14428:2008+A1

To obtain a copy of the Declaration of Performance for this product, please go to: www.ce-dop.com, contact us on +44 (0) 1325 328034, or write to us at the above address, quoting the product reference number where possible.



IMPORTANT INFORMATION

- Toughened glass is completely safe for use in our shower enclosures and bath screens; providing our products are installed according to our guidelines.
- It is important to note that the glass must not be mounted or 'pinched' in such a way that would cause a stress point to develop in the glass. In addition, it must not be subject to any sharp impact or severe temperature fluctuation which may also cause a stress point to develop in the glass.
- Toughened glass is physically and thermally significantly stronger than standard glass. During the toughening process the stresses contained within any glass are balanced so if in the unlikely event situation any of the above occurs and the glass breaks, the glass will shatter safely into small thumbnail sized blunt fragments.

PRE-INSTALLATION CHECKS

1. Check you have the correct product. Please look at the labels on the side of the product packaging.
2. Check all the product components are in the box and the fixing kits.
3. Unpack your product and handle it with care.
4. Please check the product for defects or damage, once the installation has commenced we cannot accept responsibility for any defects or damage.
5. Please take time to read these instructions prior to installing your product.
6. Before you commence any drilling check there are no hidden electrical cables and/or water pipes.
7. No attempt should be made to re-work the toughened safety glass.
8. The installation of the product should be performed by two persons.
9. It is strongly recommended that the walls the product is going to be installed on are vertical.
10. It is strongly recommended the product is fitted on a tiled surface or similar waterproof surface.
11. It is strongly recommended the walls are tiled and grouted before the product is installed.
12. If the walls and/or the tray are not level you will not achieve maximum adjustment of the product.
13. Pictures used are for illustration purposes only, product designs may alter slightly as a result of continuing product development.
14. We do not stipulate where the European Standard Kite Mark should be positioned on the glass when being factory assembled.
15. Please note that some natural misting may occur when you remove this product from its packaging, due to the addition of the glass protection pre-coating. If this does occur this can easily be removed with a soft, dry cloth.

Component Check List: Supplied

Description	Quantity
Wall Profiles	2
Bifold Door Assembly	1
Door Handle Assembly	1

Equipment Check List: Not Supplied

Description
6mm Masonry Drill Bit
4.5mm Drill Bit
2.5mm Drill Bit
Mains / Battery Drill
Spirit Level
Screwdriver
Sealant Gun
Bathroom Sealant
Tape Measure
Pencil
Additional Fixings if going into Plasterboard etc.

Fixing Kit Components

Description	Quantity
Wall Plugs	6
40mm Screws	6
9mm Screws	6
Screw Bases	12
Screw Cover Caps	12
Top Cap (Left Hand)	1
Top Cap (Right Hand)	1

CONSUMER GUARANTEE

Please make sure the purchaser/end user completes and returns the guarantee card which is enclosed with this product. Failure to validate the Guarantee will mean only the 1 Year Statutory Guarantee will apply.

Step 1 - Pre-Installation Checks

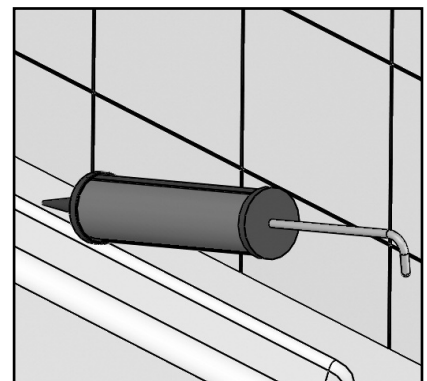
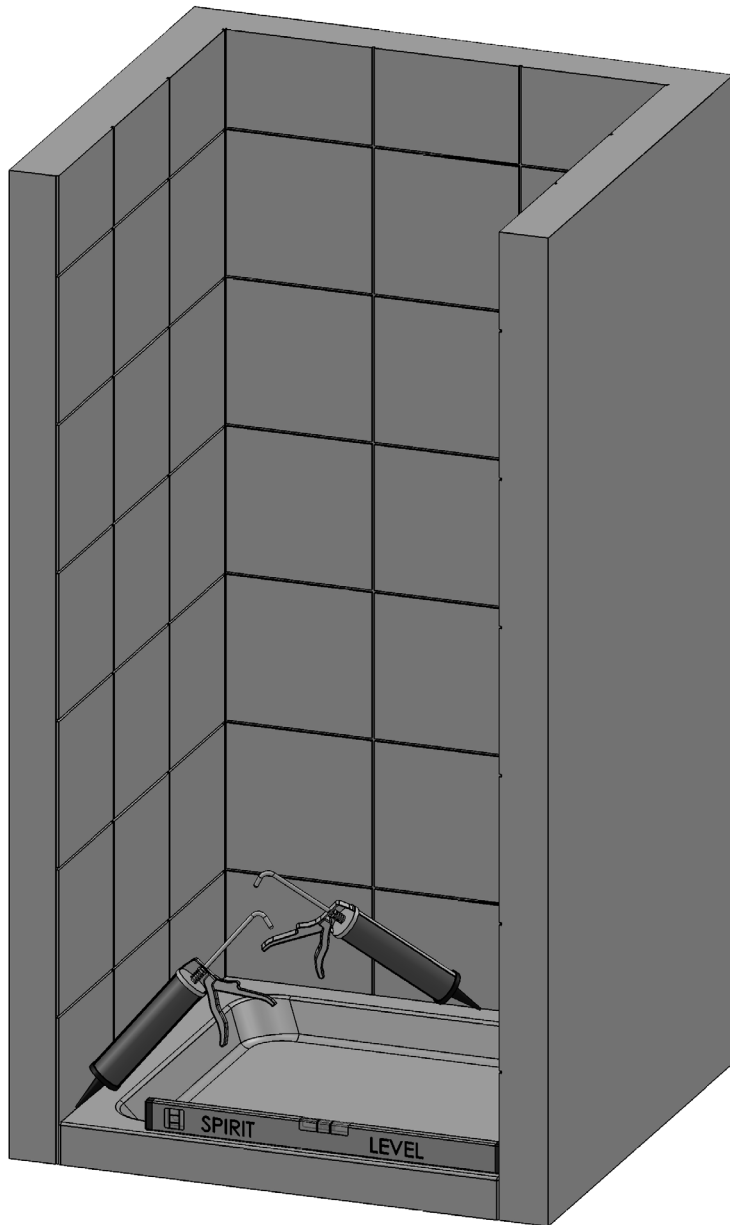

1. Check the tray is level on all sides (the bubble on the spirit level must be in the centre of the 2 lines).
 2. Stand in the tray and check that there is no adverse movement (correct if necessary).
 3. The walls should be tiled and grouted up to the tray.
 4. The tiles and the tray should be sealed using a good quality bathroom sealant.
- **Spray the seal and joints with the shower head and check for leaks when the silicon has cured.**
 - **Check the plumbing for leaks.**
 - **DO NOT plasterboard over the tray.**
 - **DO NOT grout the tiles when the enclosure has been fitted, the grout may discolour the aluminium profiles.**
 - **Make sure the tray is installed as per the manufacturer's instructions.**
 - **When all of the above has been completed please proceed to the Step 2.**

Step 2 - Wall Profile Positioning

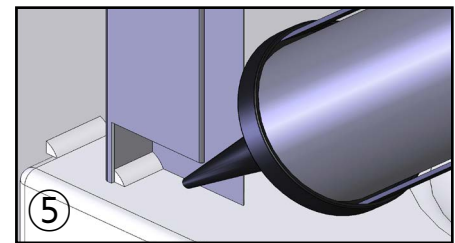
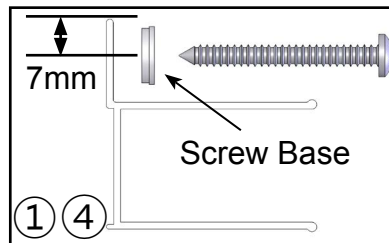
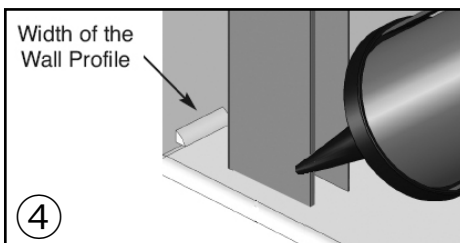
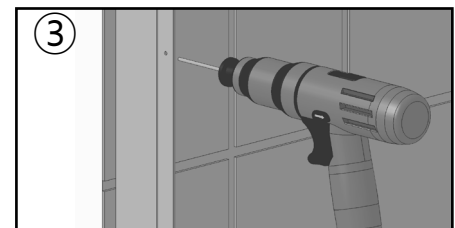
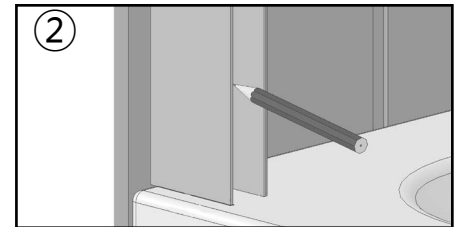
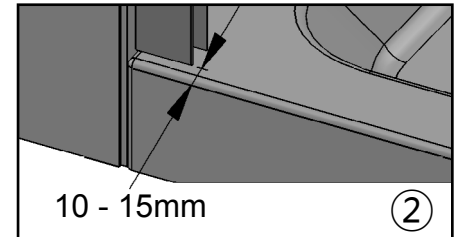
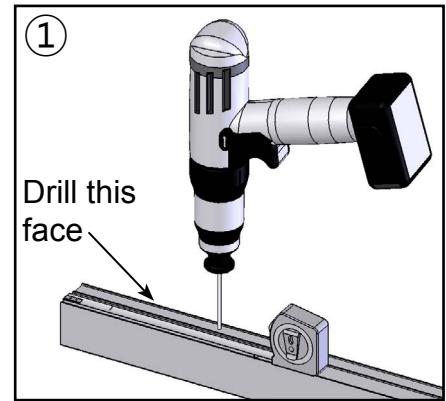
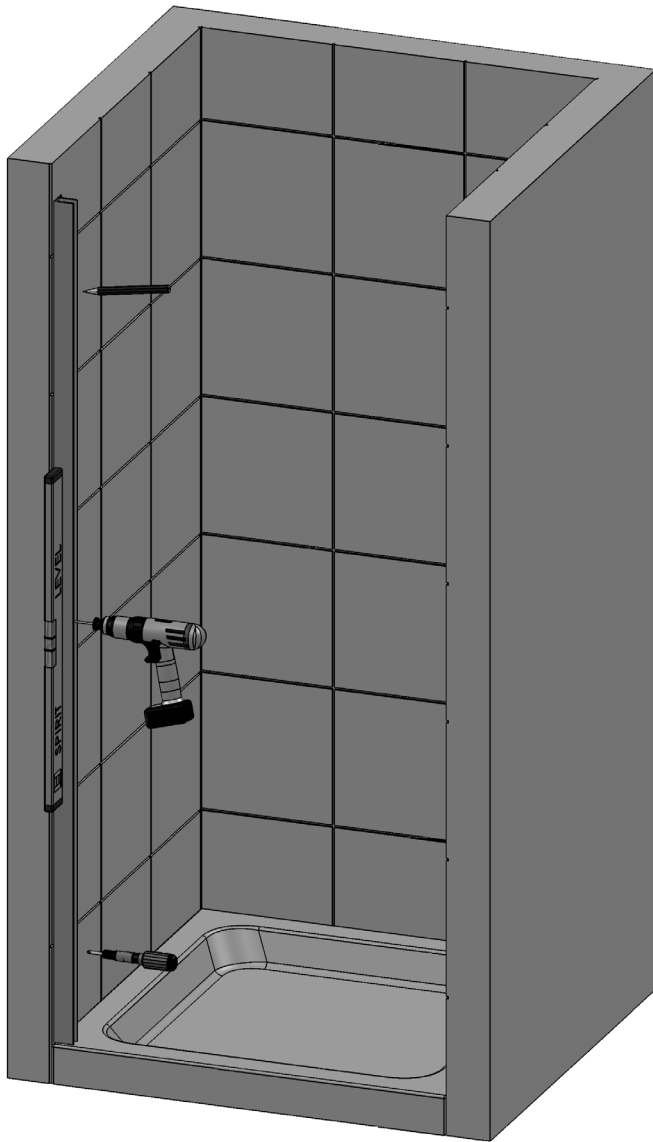

- On both wall profiles drill three 4.5mm holes through the lip. Place them 7mm in from the edge and approximately 100mm from each end and the other positioned in the centre.
 - Drill the holes from the back (through the face that goes to the wall) - deburr all holes.
- Place both Wall Profiles 10 to 15mm in from the outside of the tray. Make sure that both Wall Profiles are completely vertical using a spirit level and mark the wall through the holes with a pencil.
- Drill the wall with a 6mm Masonry Drill Bit (not supplied) where the Wall Profiles are to be positioned. Fit the Wall Plugs supplied (if going in to a brick or block wall). If going into a plasterboard wall you will need to purchase appropriate wall fixings. Wipe clear all debris from the Tray before referring to the next stage.
- Take one Wall Profile and position it on the Tray, place a bead of Bathroom Sealant (not supplied) the width of the Wall Profile between the tiled wall and tray. Fit Screw Bases to the 40mm screws (supplied) and secure the Wall Profile to the wall. Do not over tighten the screws into the Wall Profile as this will misshape the Wall Profile. Ensure the Wall Profile stays completely vertical throughout this procedure using a Spirit Level.
 - NOTE: Only one Wall Profile is fitted at this time, the other Wall Profile is fitted later.**
 - No sealant should be present between the Wall Profiles and the tiled walls vertically prior to screw fixing.**
- Seal the gap between the Tray and Wall Profile with a Bathroom Sealant (not supplied).
 - Failure to carry out Stages 4 & 5 can result in serious water damage and is not covered by the Guarantee.**

Step 3 - Positioning the Door & Second Wall Profile

NOTE: This part of the installation requires 2 people.

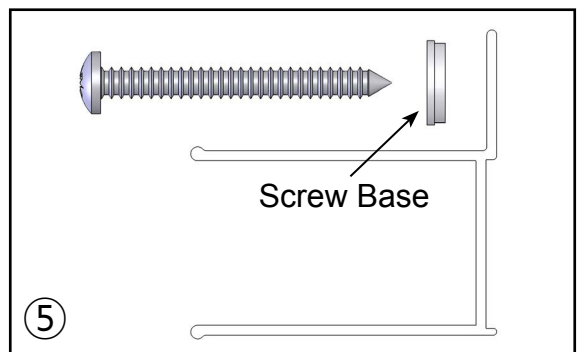
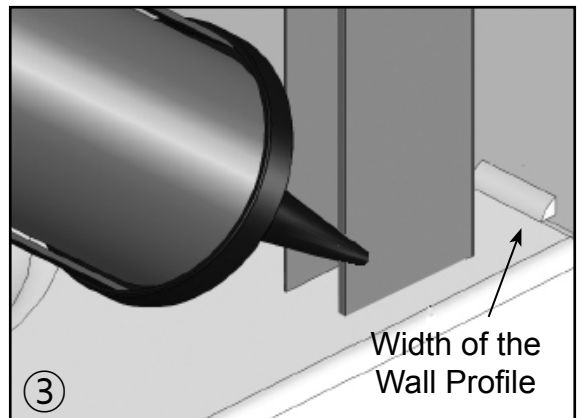
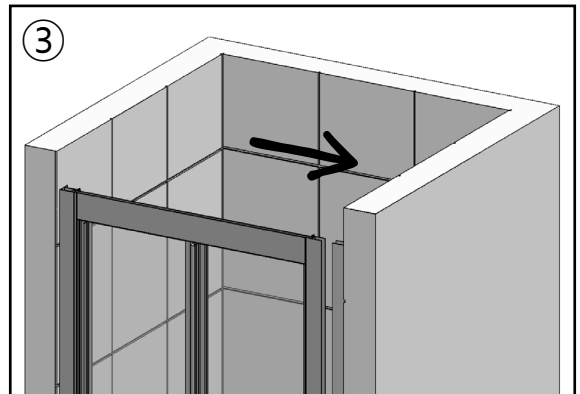
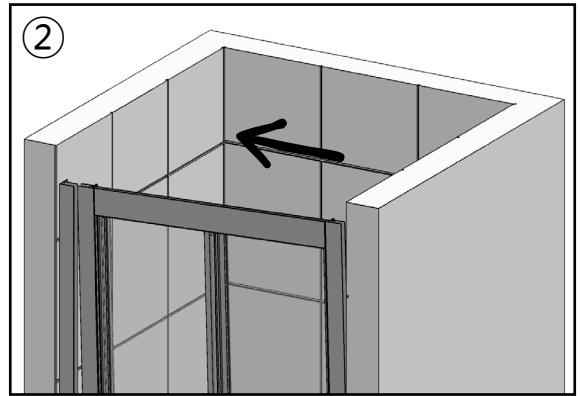
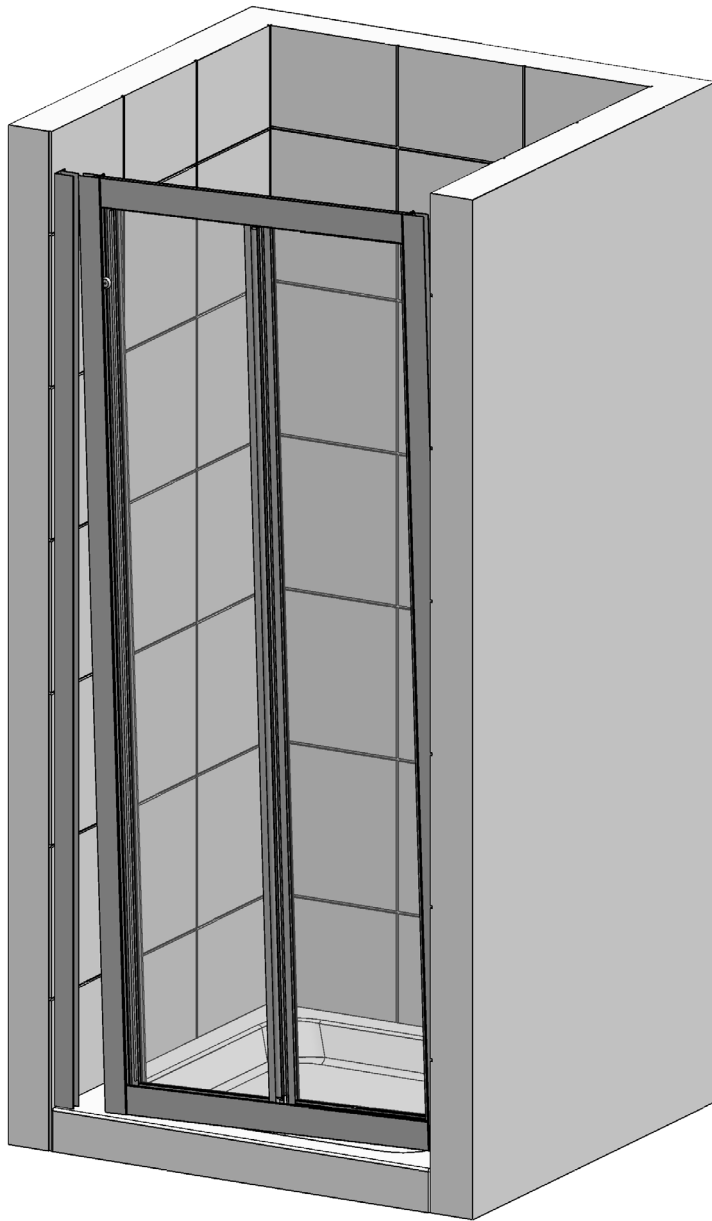

1. Place the remaining Wall Profile at the required end of the Door.
2. Gently lift the Door and Wall Profile onto the tray and into the already fixed Wall Profile.
3. Where the unfixed Wall Profile will meet the tiled wall and tray apply a generous bead of sealant.
4. Position the Wall Profile so that it locates over the previously fitted wall plugs.
5. Fit Screw Bases to the 40mm screws (supplied) and secure the Wall Profile to the wall. Do not over tighten the screws into the Wall Profile as this will misshape the Wall Profile. Ensure the Wall Profile stays completely vertical throughout this procedure using a Spirit Level.
6. Position the Door equally between the Wall Profiles, there must be at least 10mm left for fixing.

Step 4 - Fitting the Door and Handle

NOTE: This part of the installation requires 2 people.

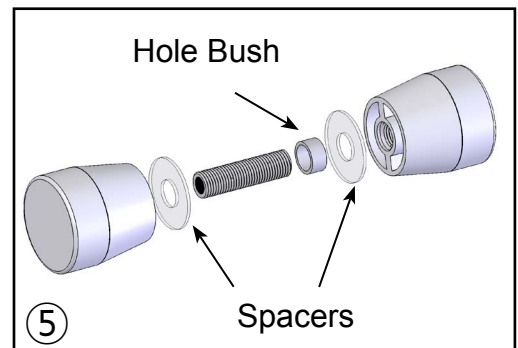
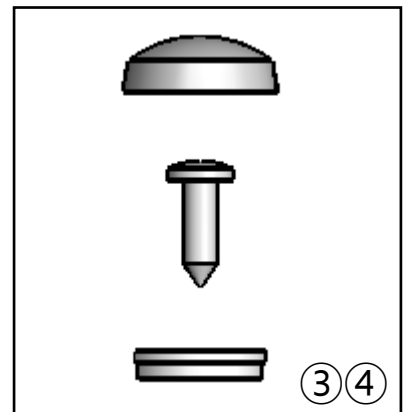
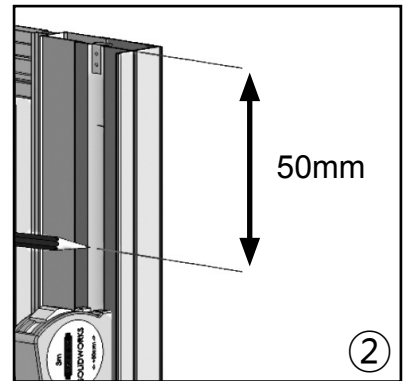
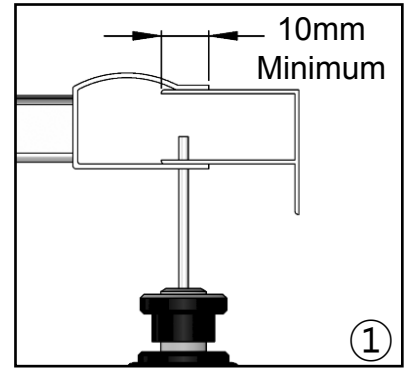
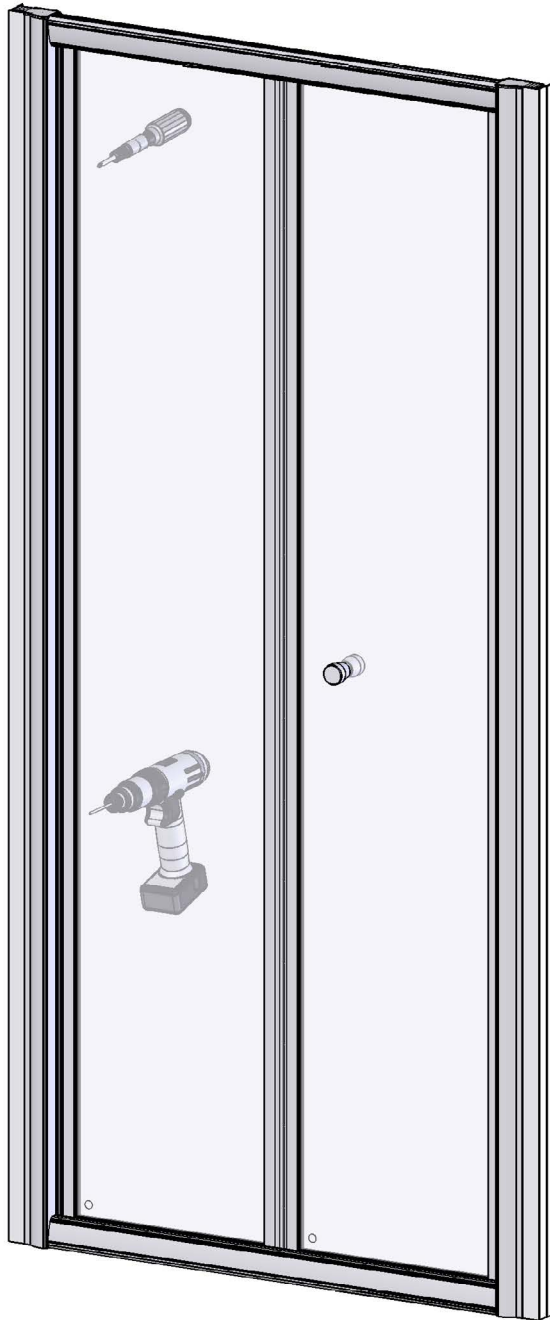

1. Make sure the Door is positioned equally between both Wall Profiles with a minimum of 10mm for drilling.
2. Drill three 2.5mm holes through the Vertical Frame of the Door into the Wall Profiles, they are to be drilled approximately 50mm from each end with the other in the centre.
3. Fit the Screw Bases onto the 9mm Screws and screw the Door to the Wall Profiles using a screwdriver.
4. Fit all the Screw Cover Caps in the enclosure.
5. Dismantle the Handle Assembly and re-assemble onto the Door Glass. Make sure the Hole Bush is fitted between the screw and glass and the Spacers are fitted each side of the Door.

Step 5 - Sealing and Top Caps

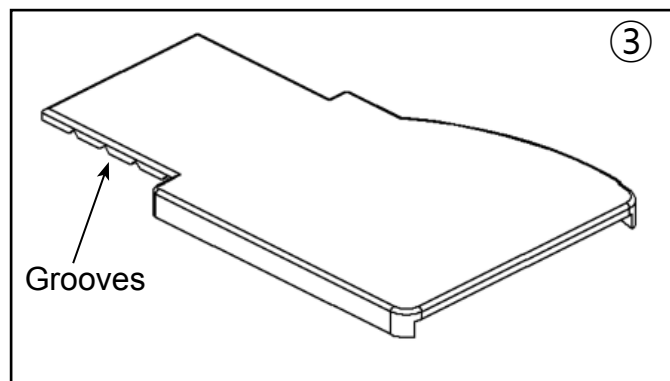
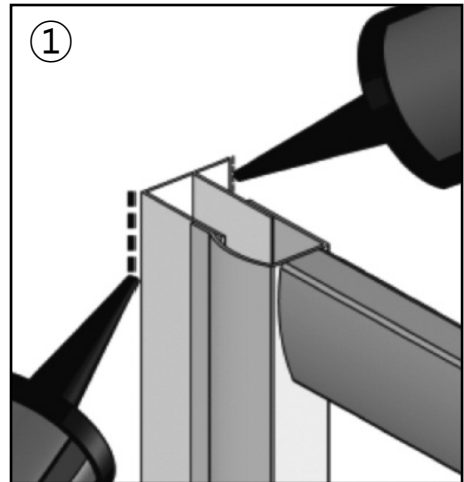
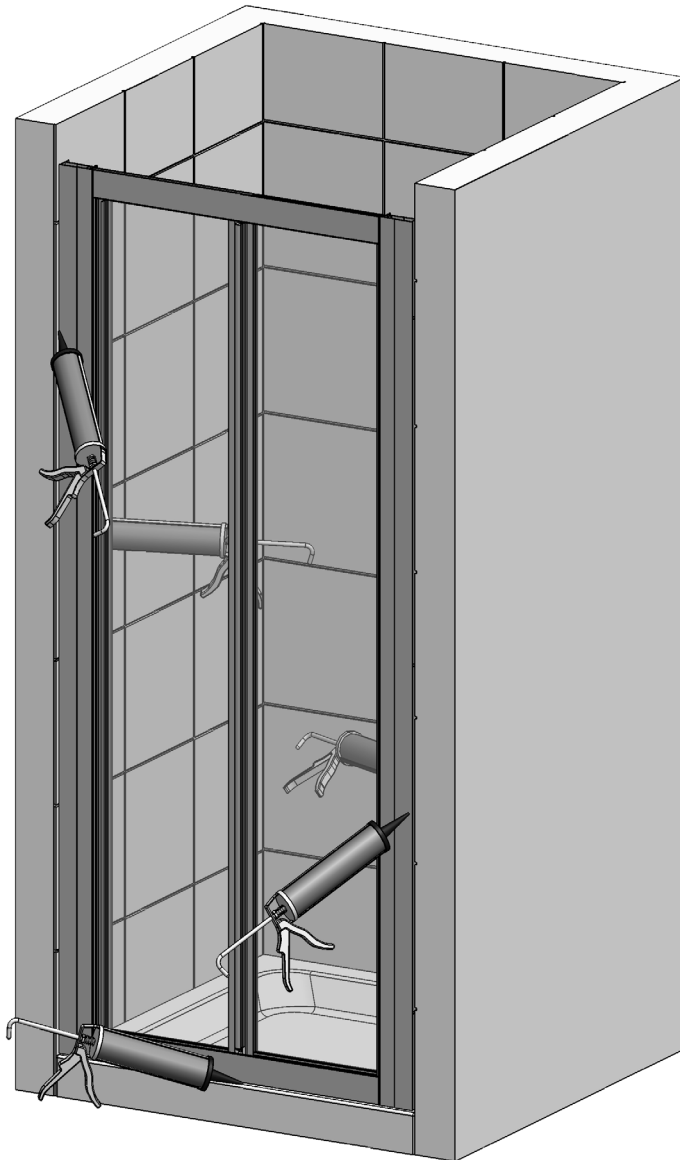

1. Seal both sides of the Wall Profiles vertically inside and outside where they meet the tiled Walls.
2. Fully seal the Bottom Horizontal Rail to the top of the tray on the outside only from wall to wall.
 - **IMPORTANT: Failure to carry out stages 1 and 2 may result in serious water damage and is not covered under the terms of the guarantee.**
 - **DO NOT seal the base of the product to the inside, failure to comply may result in the product leaking.**
3. Please allow 24 hours for the sealant to cure prior to using the enclosure.
4. Fit the Top Caps to the top of the Door Frame.
 - **NOTE: The Top Caps have grooves and can be shortened by snapping off at these points.**

Spare Parts

If you need to replace any damaged parts please see illustration below for parts list then call Customer Relations on 01325 328033



Part No.	Description	Q'ty	Part No.	Description	Q'ty	Part No.	Description	Q'ty
1	Wall Profiles	2	11	Door End Covers	2	21		
2	Vertical Frames	2	12	Door Handle Assembly	1	22		
3	Linear Seals	2	13	Plain Door Assembly	1	23		
4	Top Cap (Left Hand)	1	14	Anchor Blocks	2	24		
5	Horizontal Frames	2	15	Door Centre Seal	1	25		
6	Door Stops	2	16	Top Hat Washers	8			
7	Door Centre Mouldings	2	17	Bearing Mouldings	2			
8	Frame Magnets	2	18	Wheel Bearings	2			
9	Top Cap (Right Hand)	1	19					
10	Handled Door Assembly	1	20					

TROUBLE SHOOTING GUIDE

Problem	Solution
Leaking	<ol style="list-style-type: none">1. Check that the inside gap between the Tray and Wall profiles has been sealed correctly.2. Ensure the tray is sealed along the tiled walls prior to installation.3. If the inside joint between the enclosure and the tray top is sealed, this will cause leakage - sealant must be removed.4. Ensure the wall profiles on the tiled walls are sealed both vertically inside and outside.5. Ensure the joint between the enclosure and tray top is sealed. <p>Important: This enclosure should be water tested conforming to BS EN 14428</p>
Enclosure Alignment on the Tray	<ol style="list-style-type: none">1. Is the enclosure fitted onto a tiled wall?2. Is the bottom rail fitted 10 to 15mm from the front outside edge of the tray?3. Are the wall profiles completely vertical?
Door not running Smoothly	<ol style="list-style-type: none">1. Ensure both wall profiles are completely vertical.2. Ensure the tray is completely level.3. The Bearing Moulding may need moving to let the bearing run better.
Door Alignment	<ol style="list-style-type: none">1. Ensure both wall profiles are completely vertical.2. Ensure the tray is completely level.3. Check both Wall Profiles are in line with each other.

Some important information to help you Maintain your product.

The following information is all you need to keep your product looking new.

Clean your product using a mild detergent diluted in water and then polished off using a soft cloth.

If you live in a hard water area, periodically clean your product using a 50/50 solution of white vinegar and water. The solution should be left on the enclosure for approximately 5 minutes then rinsed off using warm water. This method of cleaning should remove lime scale residue.

Simple Maintenance

Our products are generally maintenance free, however it may be necessary to lubricate wheel assemblies and other moving parts from time to time.

It is strongly recommended that a quality silicone spray is used.

A list of Don't's:

1. Don't use acidic based products which are unsuitable for cleaning enamel surfaces.
2. Don't use abrasive cleaners or cleaners using bleach or solvents, these products will adversely affect the finish of the aluminium profiles.
3. Don't use scouring pads, powder or any sharp instruments when cleaning the enclosure.

Should you experience any problems during installation please refer to the Trouble Shooting Guide or contact Customer Relations on:

+44 (0) 1325 328033

To enable customer relations to provide you with an excellent level of service it is important that you quote your product Code and Reference Number - these can be found on the Guarantee card.