

# Accessories

## Resort Chrome 600mm Shelf and Brackets

**RAK**  
CERAMICS

### SPECIFICATION/CODE REFERENCE

Please use the reference codes shown below:

## RAKC17124



SIZE	600 x 50 x 78 mm
MATERIA	Brass, Chrome Plating
WEIGHT	0.68kg
FIXING	Supplied with back plate for concealed fittings
THICKNESS	Chrome 0.3 UM, Nickle 6019 UM
WARRANTY	Two years

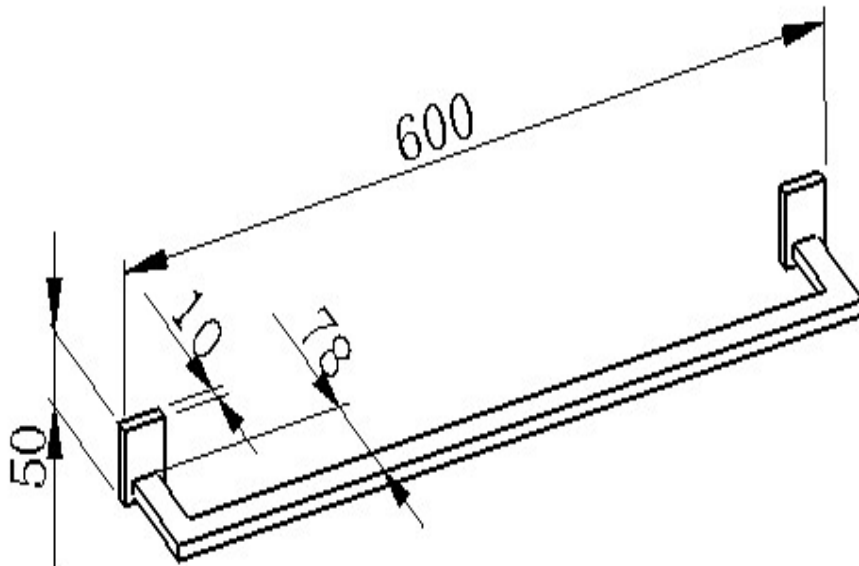

Dimensions: All measurements are in millimeters and are subject to normal manufacturing variations.

Note: Due to a continuing development programme to improve design and performance, the manufacturer reserves all rights to vary specifications without prior informations. Please note accessories are for photographic use only.

Tel: 01730 237850 Fax: 01730 263210. RAK Ceramics, Bradford House, Frenchmans Road, Petersfield, Hampshire  
GU32 3AW

Contact us at: [info.uk@rakceramics.com](mailto:info.uk@rakceramics.com) / Visit us at: [www.rakceramics.com](http://www.rakceramics.com) 2017