

 *Thermostatic Care* **QI**

 *Thermostatic Plus* **QI**

Thermostatic Control
Instantaneous Electric Shower
Installation and User Instructions

IMPORTANT!

**This Step-by-Step guide should be given to the customer
after installation and demonstration.**

CONTENTS

QI FEATURES

QI Features	2
Pack Contents	3
Installation	
1. Shower Unit Familiarisation	4
2. Installation Check List	4
3. Important Safety Information	5
4. General Installation Layout Guide	7
5. Important Installation Information	8
6. Fixing the Shower to the Wall	9
7. Product Positioning Guide	10
8. Plumbing Connections	11
9. Electrical Connections	13
10. Changing the Operational Programmes	16
11. Fitting the Front Cover	18
12. Riser Rail Fitting Instructions	19
13. Commissioning the Shower	20
User Guide	
14. Operating the Shower	22
15. How Your Shower Works	24
16. Routine Maintenance	25
17. Troubleshooting and FAQs	26
18. Troubleshooting Checklist for the Installer	28
19. Product Warranty	29
20. Service Policy	31



QUICK INSTALLATION a guide for installers

The MX range of QI Thermostatic Care and Plus shower models have been specially designed for Quick Installation. Both water and electrics can enter the shower unit from 8 different positions. The unit is wired internally to accept mains cable from both the left and right hand sides of the back plate.

Removable corner sections allow for easy plumbing connections. The screw mounting hole positions are visible when the front cover is removed. The top two fixing holes are vertical key hole slots and the bottom fixing hole is a horizontal slot to allow for alignment. The inlet water filter is positioned so that it can be removed quickly without taking the front cover off for routine maintenance.

The MX QI Thermostatic Care and Plus electric showers are designed for domestic, light commercial and healthcare applications and are approved to the BEAB Care performance standard.

These instructions contain all the necessary fitting and operating instructions for your electric shower. Care taken during the installation will provide a long, trouble free life from your shower.

PACK CONTENTS

Please make sure ALL components are included before starting the installation.

1. Shower Unit
2. Shower Handset
3. Riser Rail Tube
4. Riser Rail Brackets x2
5. Riser Rail Height Adjuster
6. Flexible Shower Hose
7. Soap Dish
8. Hose Retaining Ring
9. Additional Wall Handset Bracket (Care model only)
10. Screw Packs
11. Installation and User Instructions plus Guarantee Card

Shower accessories shown may vary with product type.

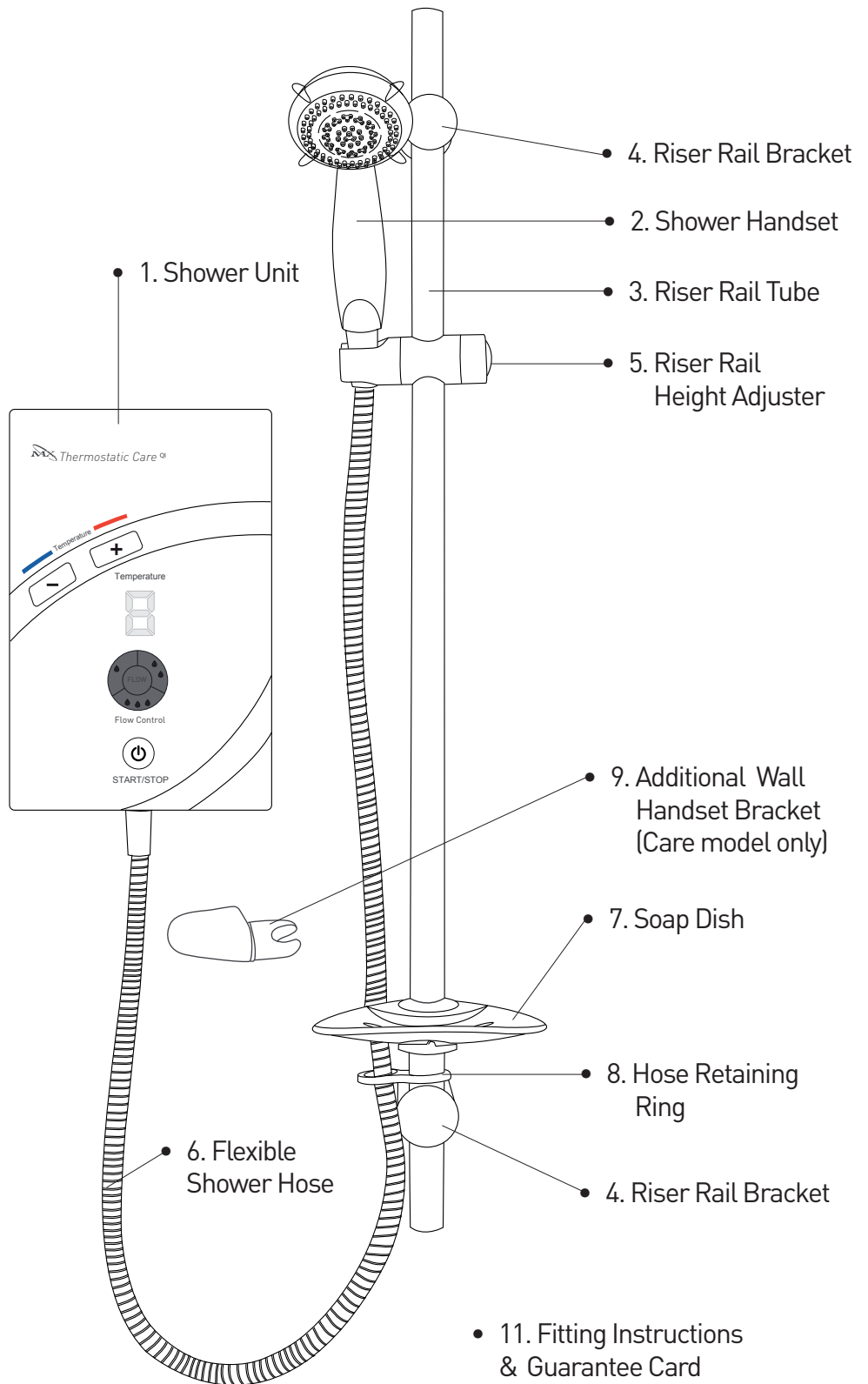

- 10. Screw Packs

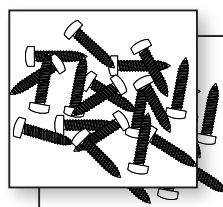

- 11. Fitting Instructions & Guarantee Card

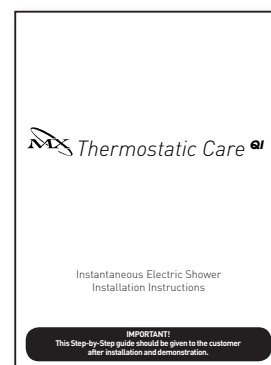

1. SHOWER UNIT FAMILIARISATION

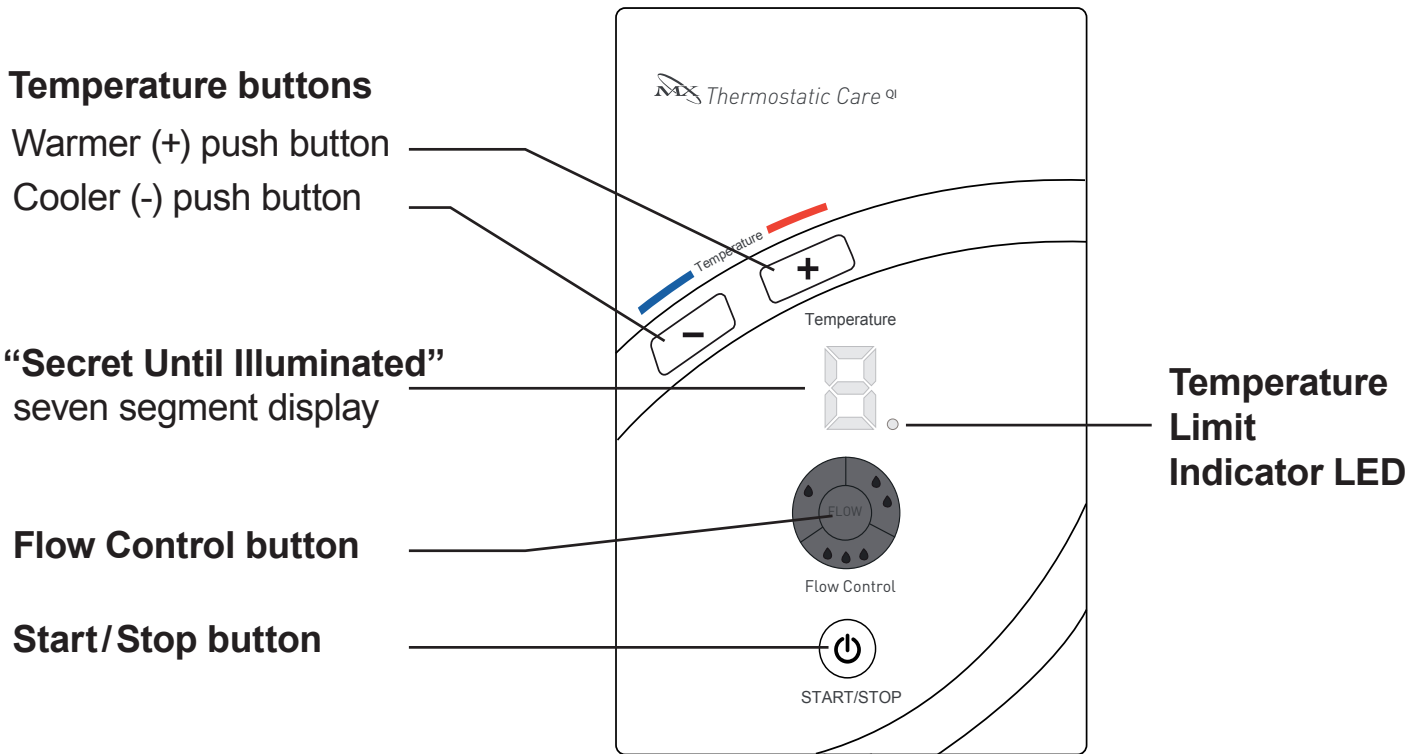

NOTE: The “Secret Until Illuminated” seven segment display indicates the shower outlet water temperature and shows through the front cover when the shower is operating. In addition the display is programmed to show error codes should a fault occur.

The temperature limit LED indicates, when lit, that the unit has a maximum pre-programmed shower outlet temperature.









2. INSTALLATION CHECK LIST

- | | | | |
|-----|--|--------------------------|--------------------------|
| 1. | <i>Check that the water supply will satisfy requirements</i> | <input type="checkbox"/> | Tick off as you complete |
| 2. | <i>Check that water and cable entry points of the unit meet requirements</i> | <input type="checkbox"/> | |
| 3. | <i>Check that the electric supply will satisfy requirements</i> | <input type="checkbox"/> | |
| 4. | <i>Select a suitable position for the shower</i> | <input type="checkbox"/> | |
| 5. | <i>Plumbing installation</i> | <input type="checkbox"/> | |
| 6. | <i>Electrical installation</i> | <input type="checkbox"/> | |
| 7. | <i>Fit to the wall and connect the shower supplies</i> | <input type="checkbox"/> | |
| 8. | <i>ONLY Commission the shower in the way described</i> | <input type="checkbox"/> | |
| 9. | <i>Fitting the front cover and aligning the controls</i> | <input type="checkbox"/> | |
| 10. | <i>Familiarise yourself with the user operating instructions</i> | <input type="checkbox"/> | |

3. PLEASE READ THIS IMPORTANT SAFETY INFORMATION

Products manufactured by the MX Group are safe and without risk provided they are installed, used and maintained in good working order in accordance with our instructions and recommendations.

FOR THE USER:

-  **WARNING: DO NOT** operate shower if frozen, or suspected of being frozen. It must thaw out before using.
-  **DO NOT** operate the unit if the showerhead or spray hose becomes damaged.
-  **DO NOT** restrict flow out of shower by placing showerhead in direct contact with your body or other solid object.
-  **WARNING:** the outlet of the shower acts as a vent and must not be connected to anything other than the flexible shower hose and handset supplied or approved by the manufacturer.
-  **DO NOT** operate the shower if water ceases to flow during use or if water has entered inside the unit because of an incorrectly fitted cover.
-  **DO NOT** place items such as soap, shampoo or other such bottles on top of the unit as liquid could leak through the joint between the cover and back plate and damage the sealing rubber.
-  The shower spray head and shower inlet filter **MUST** be cleaned regularly to remove scale and debris. The frequency of the cleaning will vary according to the local water quality. If the water outlet temperature becomes hot and you are unable to obtain cooler water, immediately check the shower handset and inlet filter for blockage. See section 16 for cleaning instructions.
-  **IMPORTANT:** This appliance is not intended for use by persons (including children) with reduced physical, sensory or mental capabilities, or lack of experience and knowledge, unless they have been given supervision or instruction concerning use of the appliance by a person responsible for their safety. Children should be supervised to ensure they do not play with the appliance.

FOR THE INSTALLER:

DEFAULT PLUMBING SETTING: The shower unit is supplied for right hand mains water connection. To plumb the unit from the left of the shower back plate you must remove the blanking cap by sliding off the metal retaining clip and refit to the right hand side of the unit ensuring the metal retaining clip is refitted and pushed firmly into the groove. Whilst leak testing the installation please ensure that there is NO water leaks from this area. See Section 8: Plumbing Connections.

IMPORTANT: To comply with water regulations, building regulations or any specific local water company regulations and in accordance with BS EN 806 a double check valve should be fitted where it is possible that the shower head may come into contact with used water, for example in the bath or a shower tray.

IMPORTANT: Check that there are no hidden cables or pipes before drilling holes for the wall plugs. Chose a flat piece of wall to avoid the possibility of distorting the back plate and making the front cover a poor fit. Exercise great care when using power tools near water. The use of a residual current device (RDC) is recommended.

IMPORTANT: Before connecting the water supply to the shower unit the water supply pipe should be flushed out to remove all debris. After flushing the pipe work make the connection to shower inlet and ensure the shower is positioned squarely on the wall and all fixing screws are tightened.

IT IS VERY IMPORTANT to ensure that the terminal block screws are **FULLY** tightened and that no cable insulation is trapped under the screws. The earth continuity conductor of the electrical installation must be effectively bonded to earth on the fuse board.

IMPORTANT: Ensure that the flow control knob is turned to FULL flow and the commissioning instructions are followed before switching the unit on. This will make sure that the unit is full of water when first activated.

IMPORTANT: The shower unit **MUST** be full of water before the heat settings are used.

4. GENERAL INSTALLATION LAYOUT GUIDE

Plan your installation carefully. Check on the nearest and most accessible rising main water supply, this may be beneath the bath or in the loft, where it feeds the water storage tank. Use only the cold rising water main.

Avoid connecting the shower unit if possible where it will be affected by water drawn off by another appliance. For example from the mains feed to the toilet

as this may cause a drop in pressure to a level that is too low for the shower unit to work correctly.

A WRAS (water regulations advice scheme) listed isolating valve must be fitted between the rising main and the unit to comply with water regulations and to allow for routine maintenance and servicing.

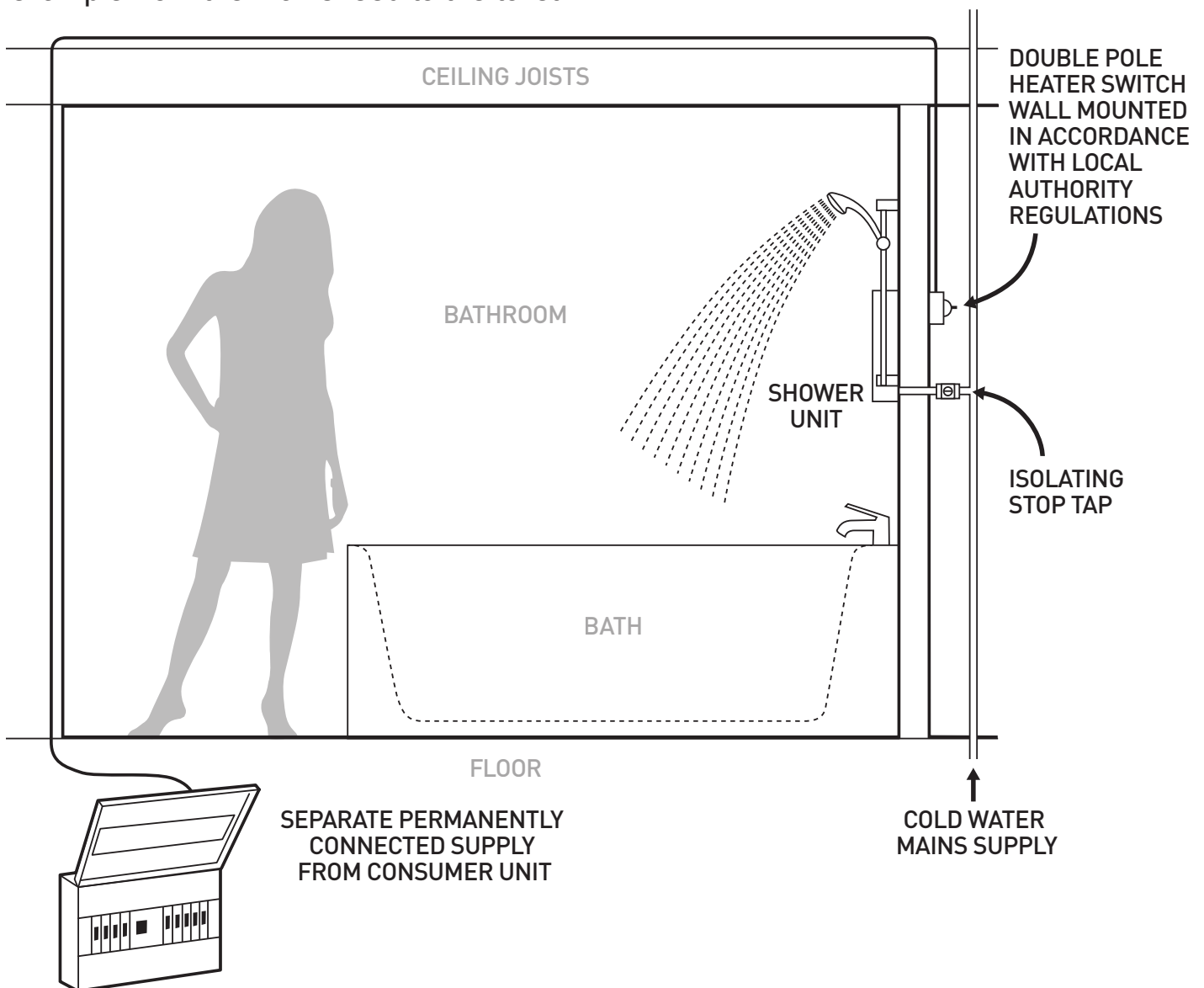

⚠ IMPORTANT ⚠

This appliance is not intended for use by persons (including children) with reduced physical, sensory or mental capabilities, or lack of experience and knowledge, unless they have been given supervision or instruction concerning use of the appliance by a person responsible for their safety. Children should be supervised to ensure that they do not play with the appliance.

5. IMPORTANT INSTALLATION INFORMATION

■ Shower installation must be carried out by a suitably qualified person and be in accordance with BS 7671 (IEE wiring regulations) building regulations, water regulations and or any specific local water company regulations in force and should be in accordance with BS EN 806.

■ This shower unit is designed to be connected to a 15mm cold water mains supply.

■ To make sure the heating elements are activated the shower must be connected to mains water supply with a minimum running pressure of 100kPa (15lb/sq in) – 1 Bar at a minimum flow rate of 8 litres per minute. The maximum static pressure is 1000kPa (150lb/sq in) 10 Bar.

NOTE: For 9.5kW units the minimum running pressure must be obtained at 9 L/min.

For 10.5kW units the minimum running pressure must be obtained at 11 L/min.

■ The shower unit must not be fitted where it may be exposed to frost, for example in an outdoor area. The shower must not be used if suspected of being frozen. Frost damage is not covered by the guarantee.

■ Plumbers jointing compound must NOT be used.

In instances of difficult joints use P.T.F.E. Tape.

The use of jointing compound will invalidate the product guarantee.

■ **DO NOT** solder fittings near the shower unit as heat can travel along pipe work and damage components.

■ **DO** complete all plumbing connections before making the electrical connections.

6. FIXING THE SHOWER TO THE WALL

Position your shower on the wall so that it will NOT be in the direct water spray from the shower handset when fixed.

You may wish to consider mounting the unit so that the shower handset could be used over a sink for washing hair.

The shower unit should be positioned so that the shower head cannot be immersed in the bath or shower tray when hanging down. A shower hose retainer is supplied with the accessories (see pages 3 and 10).

The unit can be mounted at a lower level if required for less abled users and for use with a shower seat.

The shower unit can be mounted at a lower level if required for less abled users and for use with a shower seat. The installation should comply with the relevant British Standard covering the design of buildings to meet the needs of disabled people. It is important that if this option is chosen the shower unit must not be mounted directly in the water spray from the handset.

Remove the four front cover fixing screws and lift the cover off complete with the warmer (+) and cooler (-) push buttons and flow control knob in place.

Note: there is a connector and lead attached to the control PCB mounted on the shower back plate. This will require connecting to inside of the front cover before completing the installation.

Having decided on the water and cable entry points and chosen a flat piece of wall hold the shower vertically against the wall and mark the top two fixing holes.

Carefully drill the two holes as marked using a sharp 5.5mm masonry drill after first making certain there are no pipes or wires behind the proposed holes.

Insert the wall plugs and screws provided leaving the screw head proud by approximately 5mm. The shower can now be hung on these screws.

Make sure that the shower is positioned vertically now mark and drill the lower slotted fixing hole. Then fix the shower to the wall. Do not fully tighten the screws at this stage.

The shower back plate has moulded knock out sections which are clearly indicated to allow the chosen service entry option to be removed prior to final fix.

7. PRODUCT POSITIONING GUIDE

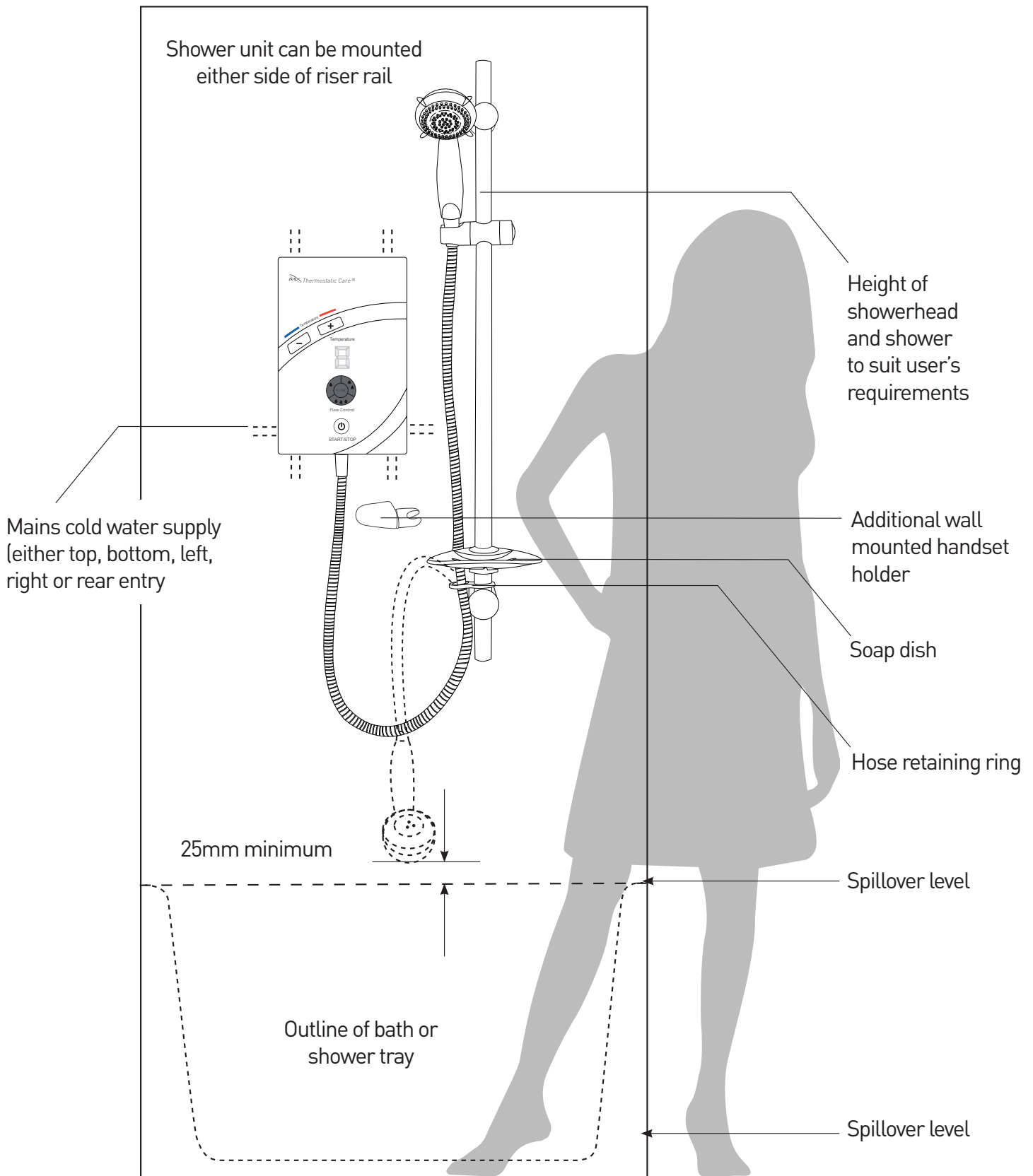

8. PLUMBING CONNECTIONS

NOTE!

PLUMBING THE SHOWER UNIT MUST PRECEDE WIRING!

QI

QUICK INSTALLATION

As you can see from the diagram right the shower unit can be both plumbed and wired from 8 different positions;

- Top right
- Top left
- Bottom right
- Bottom left
- Right side
- Left side
- Rear right
- Rear left

The 8 arrows depict water and electrical entry points

Location holes for mounting are easily marked off from inside unit

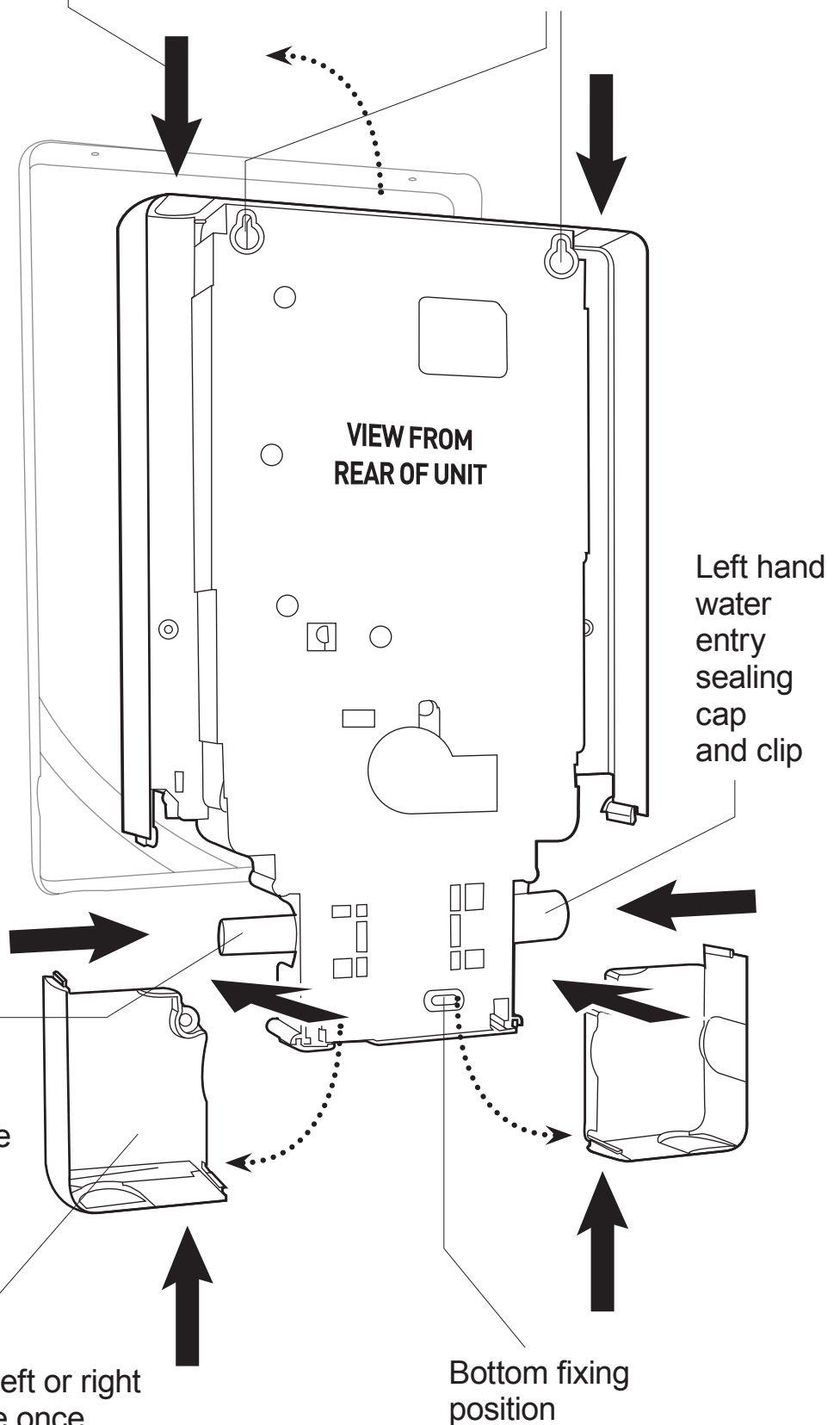

Water inlet, this can be switched with the cap and fixing clip opposite to change water input direction.

See next page for instruction.

Removable cover plates for left or right and bottom inlets, accessible once cover plate is removed. These simply slide into place and secure with fixing screw before replacement of cover.

DEFAULT PLUMBING SETTING

The shower unit is supplied for right hand installation. To plumb the unit on the left you must:

1. Remove the bottom left hand side cover plate.
2. Carefully pull the metal retaining clip out of the blanking end cap with a pair of pliers.
3. Slide off the blanking cap.
4. Refit the blanking cap on to the inlet pipe on the right hand side of the unit.
5. Re-insert the metal fixing clip ensuring it is pushed primly into place.

IMPORTANT: When leak testing the installation you must ensure there are no leaks from this area.

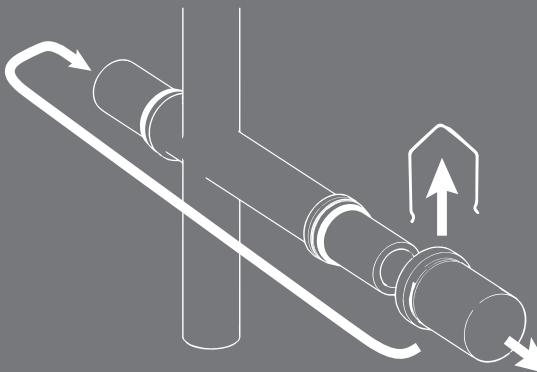

The shower back plate incorporates into the lower right and left hand side of the back plate **removable trim sections** to allow easy access when deciding on and connecting to the water mains supply.

Remove the bottom right hand side cover plate giving access to the inlet spigot.

IMPORTANT: Before connecting the mains water supply to the shower, flush out the pipe work to remove all swarf and system debris. This is achieved by connecting a hose to the pipe work and turning on the mains water supply at the isolating stop tap long enough to clear the debris to waste.

Turn off the mains water supply at the isolating stop tap.

Having decided on the direction of the water inlet supply: Top (falling) Bottom (rising) or Rear Inlet, it is necessary to remove the appropriate knock out (thinned out plastic) cross section from the back plate before commencing with the installation.

The connection to the unit is made using a 15 mm copper, stainless or plastic pipe with a 15 mm compression elbow or 15 mm push fit elbow.

IMPORTANT: Do not use excessive force when making the connection to the unit.

IMPORTANT

To comply with water regulations, building regulations or any specific local water company regulations and should be in accordance with BS EN 806. A double check valve must be fitted with all flexible shower accessories where it is possible that the showerhead may come into contact with used water i.e. In the bath or shower tray.

PLUMBING CONNECTIONS (CONT.)

Tighten the back plate fixing screws so the unit is firmly fixed to the wall.

If rear entry pipe work is used we recommend the use of a suitable sealant to seal around the incoming pipe work to prevent water entering the wall.

Turn on the mains water supply and check for leaks. At this stage no water can flow through the unit.

IMPORTANT: Remember to replace the lower inlet covers before refitting the front cover.

IMPORTANT

Before turning on the water supply to the shower unit the water supply pipe should be flushed out to remove debris. After flushing the pipework ensure that the shower unit is positioned squarely on the wall and tighten the screws. Tighten all plumbing connections and check the pipework for leaks.

9. ELECTRICAL CONNECTIONS

The electrical installation must be in accordance with the current BS 7671 (I.E.E. wiring regulations) and part P of the building and / or local regulations.

The shower unit is designed for a single phase 50 Hz a.c. electrical supply.

ELECTRICAL SPECIFICATIONS

Nominal Power rating at 240V

8.5kW - (40A MCB rating)

9.5kW - (40A MCB rating)

10.5kW - (45A MCB rating)

Nominal Power rating at 230V

7.8kW - (40A MCB rating)

8.7kW - (40A MCB rating)

9.6kW - (45A MCB rating)

IMPORTANT: The heating elements on the UK models are manufactured to 240V specification and will give a lower kW rating if the voltage supply is below 240V.

The shower unit **must be permanently connected** to the electrical supply, direct from the consumer unit via a double pole linked switch with a minimum contact gap of 3 mm. The switch must be readily accessible and clearly identifiable and sited out of reach of a person using the shower over a fixed bath or shower tray, unless the switch is pull cord operated. The wiring must be connected to the switch without the use of a plug or socket outlet.

The supply cable size is determined by the kW rating of the product (as detailed on the rating plate fixed to the back plate) and the distance between the shower and the consumer unit. The table below is for guidance only but will help you choose the correct cable for your installation. If you are in any doubt consult an electrician.

ELECTRICAL CONNECTIONS (CONT.)

KW RATING	NOMINAL AT 240V	MINIMUM RATING OF ISOLATING SWITCH	FUSE RATING	MAX CABLE RUN	
				6mm	10mm
7.5	31.25amps	40amps	40amps	29m	48m
8.0	33.33amps	40amps	40amps	27m	44m
8.5	35.41amps	40amps	40amps	23m	38m
9.5	39.58amps	40amps	40amps	21m	32m
10.5	43.75amps	45amps	45amps	18m	30m

The incoming cable should be hidden.

IMPORTANT: The shower unit is supplied with 2 separate sets of connecting terminal blocks mounted on the shower back plate so that the shower can be wired for left or right installations with minimum effort. **ONLY connect to one of the terminal blocks.**

The diagram below shows the route of the cable into the shower unit for connection to the terminal block. (illustrated on left hand side)

IMPORTANT: Remove the appropriate lower cover section to improve access for mains cable fitting.

Earth cable to terminal marked 

Neutral cable to terminal marked **N**

Live cable to terminal marked **L**

The outer sheath of the supply cable must be striped back to the minimum length as illustrated and the earth conductor must have an earthing sleeve fitted.

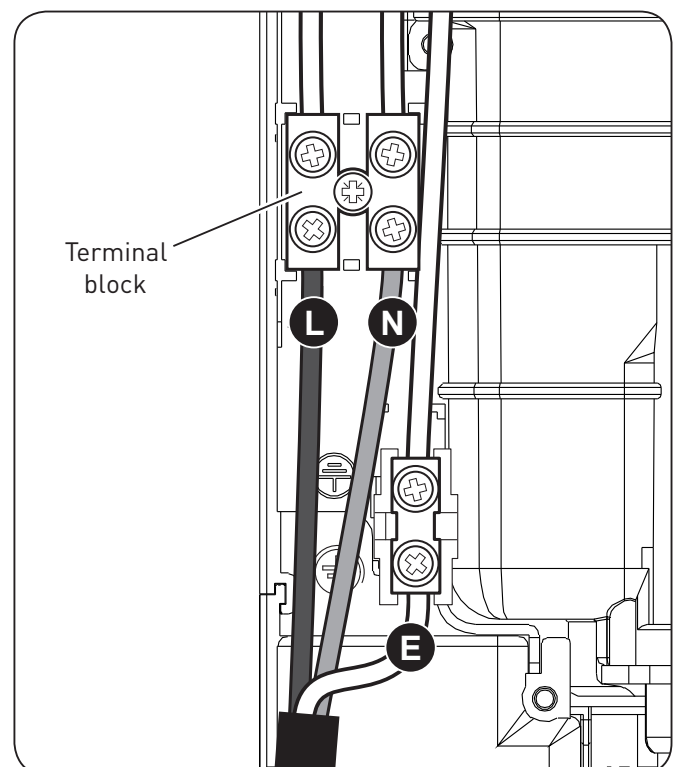

IMPORTANT

Ensure that the terminal block screws are fully tightened and that no cable insulation is trapped under screws. Ensure the cable clamp is used to secure the cable. The earth continuity conductor of the electrical installation must be effectively connected to all exposed metal parts of other appliances and services in the room in which the shower unit is installed to confirm

ELECTRICAL CONNECTIONS (CONT.)

Connect the cable to the terminal block. Ensure that ALL the retaining screws are **VERY** tight and that **NO** cable insulation is trapped under the screws. Loose connections can result in cable overheating.

IMPORTANT: Failure to ensure that the retaining screws are **VERY** tight could result in a failure of the terminal block.

IMPORTANT: DO NOT switch on the electricity supply until the shower cover has been fitted.

The diagram below shows a schematic wiring diagram.

IMPORTANT: The use of connections within the unit or other points in the

shower circuit to supply power to other equipment such as an extractor fan or pump etc will invalidate the guarantee.

1. Heater body
2. Solenoid valve
3. Thermal cut-out
4. Power PCB
5. Triac PCB
6. Flow sensor
7. Inlet/outlet temperature sensors
8. Display PCB
9. Start/Stop button PCB
10. Stepper motor

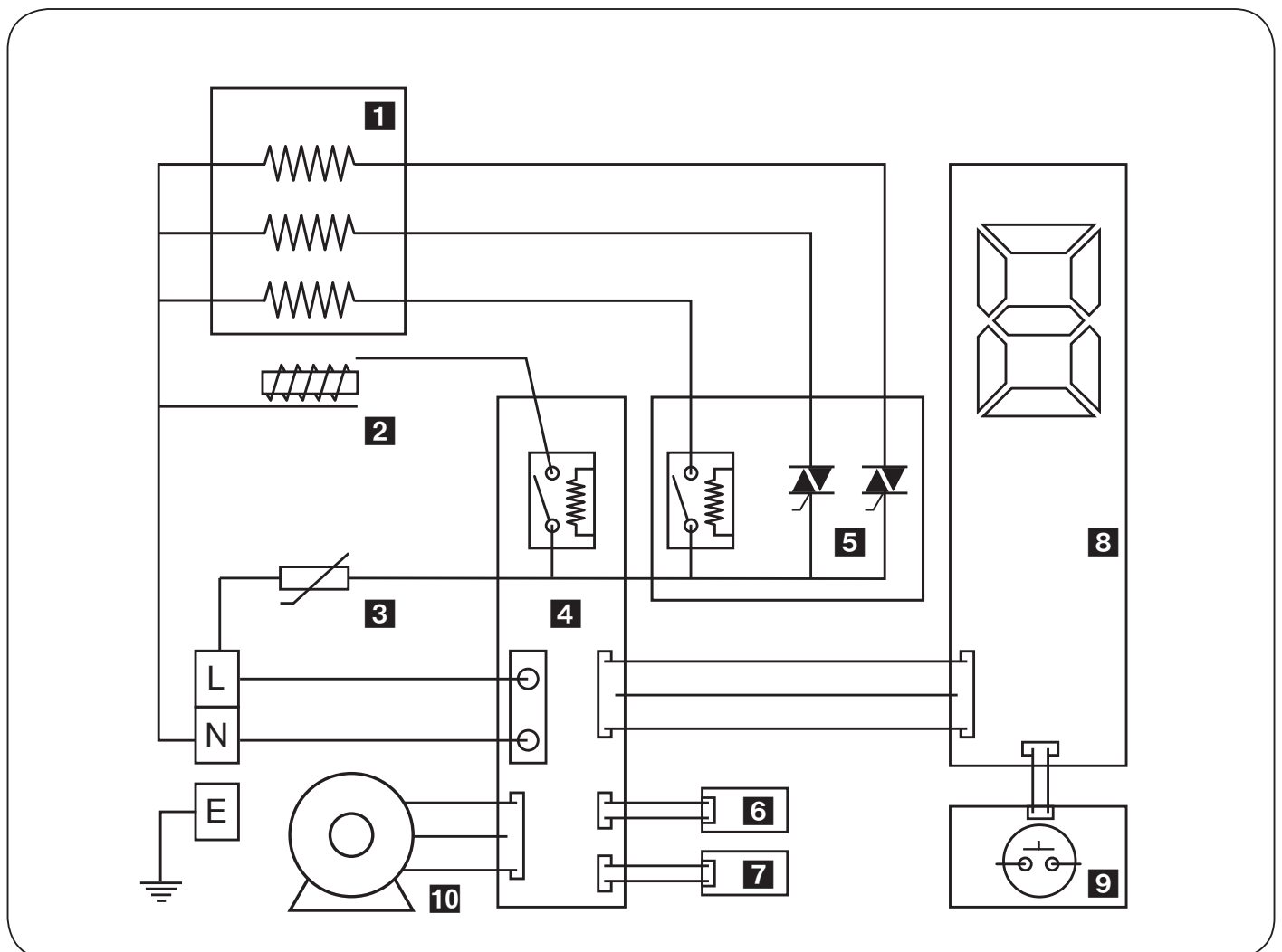

10. CHANGING THE OPERATIONAL SHOWER PROGRAMMES

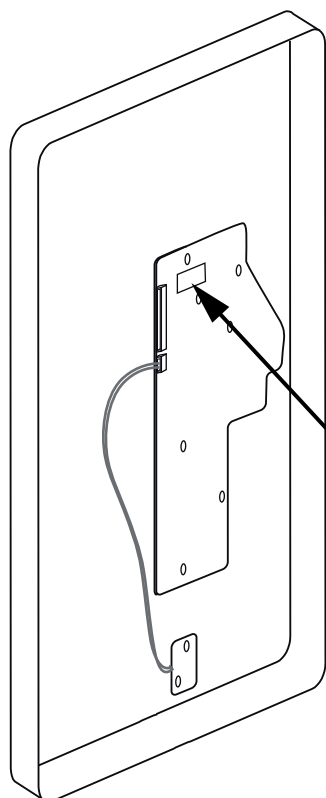

DEFAULT SETTINGS – THERMOSTATIC CARE

Sound: **ON**
 Maximum temperature:
PROG 1 (30–41 °C)
 Running time: **30 MINS**
 Temperature Start:
FIXED (nominal 40 °C)

DEFAULT SETTINGS – THERMOSTATIC PLUS

Sound: **ON**
 Maximum temperature:
PROG 3 (30–47 °C)
 Running time: **30 MINS**
 Temperature Start:
MEMORY (as last shower)

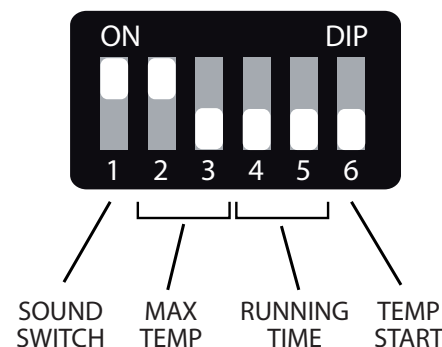
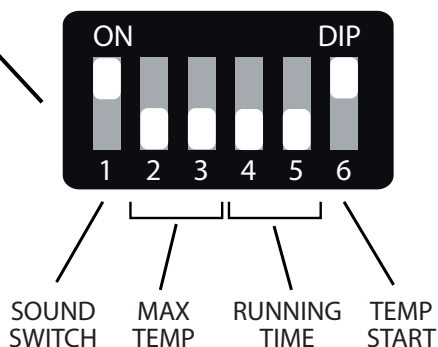

The shower has **four separate operational programmes** which can be adjusted on installation via a series of DIP switches located on the display PCB. This is mounted on the back of the front cover as shown above.

The programmes are:

- 1. Audible feedback** to confirm user command.
- 2. Maximum shower outlet temperature lock** to provide three MAXIMUM shower outlet temperature settings.
- 3. Automatic timed off operation:** four settings are available.
- 4. Shower start temperature** can be set to a FIXED 40 °C (display digit 8 on the seven segment temperature display) or MEMORY – with start up temperature as per the last shower. A double bleep confirms to the user when the outlet temperature has been reached.

IMPORTANT: The Thermostatic Care models are factory set in BEAB Care mode with settings as follows:

- the audible feedback is ON (single bleep on each push button command)
- maximum temperature lock set to PROGRAMME 1. This limits the maximum temperature selectable by the user to 41 °C at digit 9 on the numerical temperature indicator.
- automatic timed STOP feature set at the maximum duration of 30 minutes.
- shower start temperature set at a FIXED 40 °C.

NOTE: DIP switch is ON when slider switch in the upper position. DIP switch is OFF when slider switch is in the lower position.

CHANGING THE OPERATIONAL SHOWER PROGRAMMES (CONT.)

AUDIO FEEDBACK

SOUND ON

slider switch 1 ON



SOUND OFF

slider switch 1 OFF

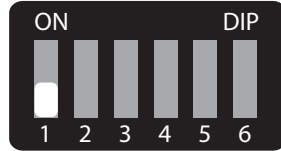

MAXIMUM TEMPERATURE

IMPORTANT: To retain BEAB Care performance the factory set Programme 1 **MUST** be used.

PROGRAMME 1

(30–41 °C)

slider switch 2 OFF
slider switch 3 OFF

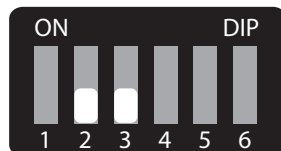

PROGRAMME 2

(30–43 °C)

slider switch 2 OFF
slider switch 3 ON

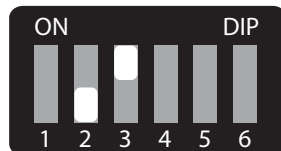

PROGRAMME 3

(30–47 °C)

slider switch 2 ON
slider switch 3 OFF

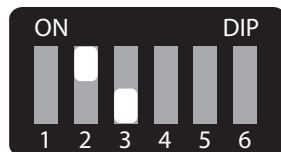

RUNNING TIME

30 MINS

slider switch 4 OFF
slider switch 5 OFF

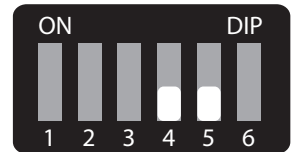

20 MINS

slider switch 4 OFF
slider switch 5 ON

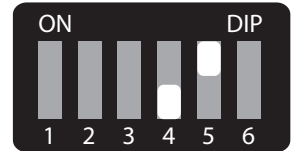

10 MINS

slider switch 4 ON
slider switch 5 OFF

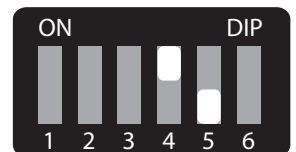

5 MINS

slider switch 4 ON
slider switch 5 ON

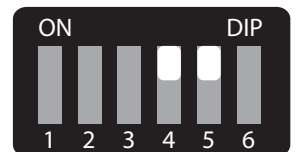

TEMPERATURE START

FIXED

(start up at digit 8 – nominal 40 °C)

slider switch 6 ON



MEMORY

(start up temperature as last shower)

slider switch 6 OFF.



! IMPORTANT !

If the programmes are adjusted following the unit commissioning switch off the electricity at the isolating switch before removing the front cover taking care not to damage the PCB flying lead and check correct operation of the shower after re-fitting the front cover.

11. FITTING THE FRONT COVER

IMPORTANT: it is necessary to align the Multi pin connector and connect the flying lead from the PCB to the rear of the front cover.

Hold the front cover carefully and attach the flying lead from the control PCB (**ensuring that the lock tags are aligned with the slots on the display PCB connector**) to the rear of the front cover as illustrated making sure that the connector pins are fully engaged.

The cover can now be fitted and secured with the four fixing screws provided.

Following the installation of the riser rail (see section 12) attach the flexible hose to the shower outlet positioned centrally on the back plate making sure that you use the seal washer provided. The shower is now ready for commissioning.

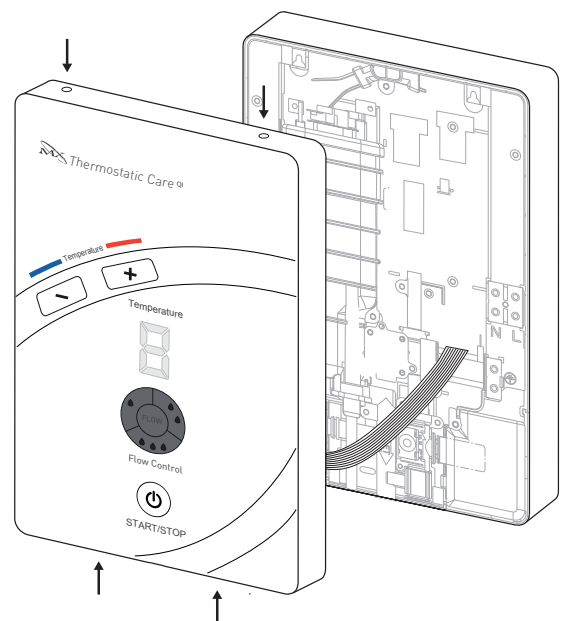
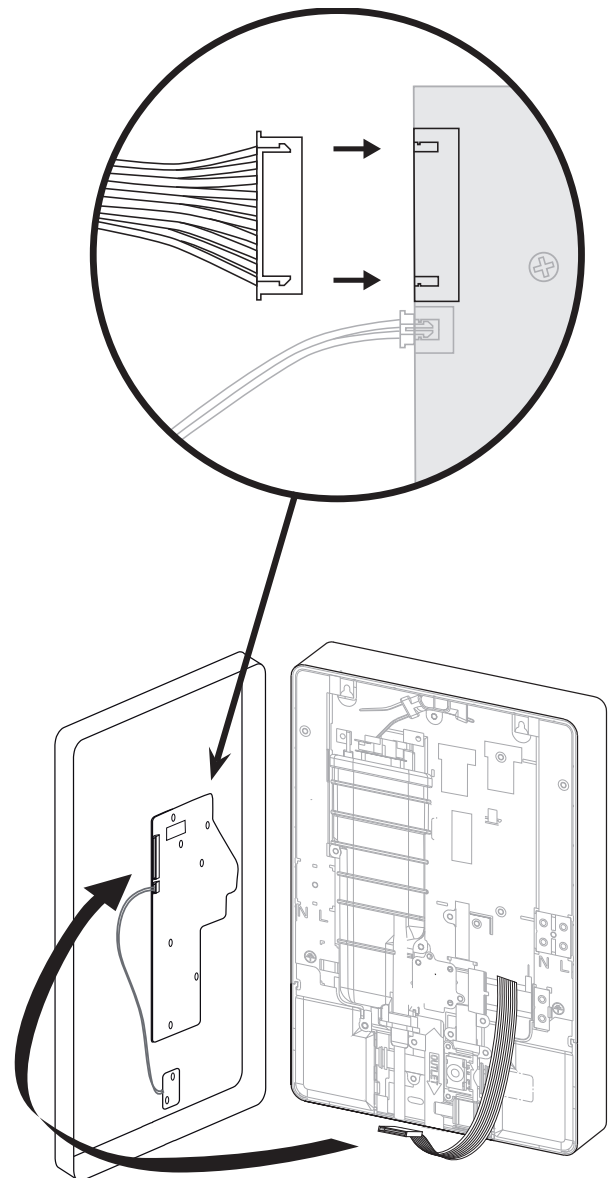

12. RISER RAIL FITTING INSTRUCTIONS

1. Establish the height of the riser rail to suit requirements, taking into account all users.
2. Remove caps and covers from brackets.
3. Mark the position of the lower bracket then drill and plug the wall. If this is a replacement installation locate the bottom hole.
4. Fit rail through lower bracket and clamp. Place the remaining bracket on top of the rail making sure the slot in the rail is located in the notch.
 - a. For a replacement riser fix the top bracket using the existing hole.
 - b. For a new installation ensure the hole position is vertically aligned and mark the wall. Unclamp the lower bracket and remove the rail then drill and plug the wall before fixing the top bracket into position.
5. Slide the height adjuster onto the rail. Tighten to the rail by turning the locking cap. Then fit the soap dish – dampening the rail will make it easier to slide on. Finally fit the hose retaining ring onto the bottom of the rail below the soap dish.
6. Replace the rail assembly through the lower bracket. Fit the rail into top bracket ensuring the slot locates into the notch. Tighten the lower bracket then refit the bracket caps.

NOTE: The adjustable height adjuster grips the conical ends of the hose, not the handle of the showerhead.

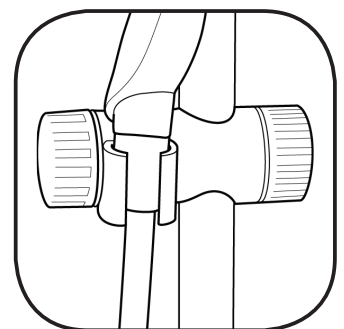
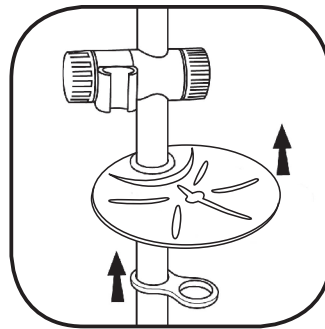
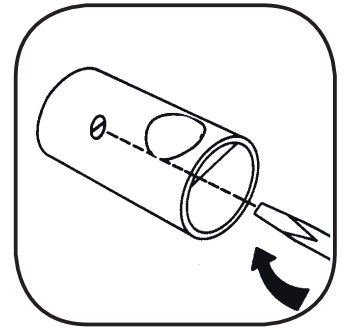
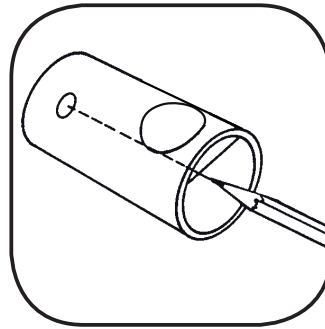
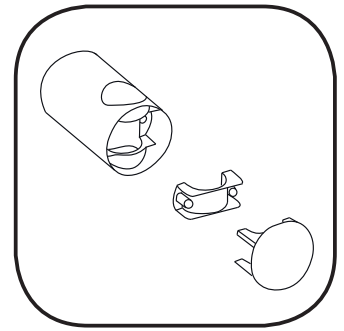
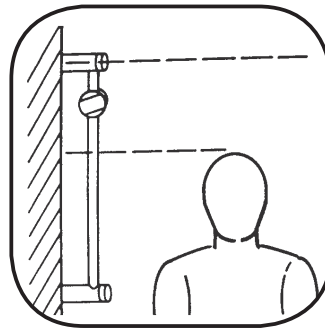

✓ TIPS

A piece of insulating or masking tape applied to the wall before marking out the Fixing holes will help stop the drill from wandering, particularly on tiled surfaces. When working near a basin or bath, insert the plug in the waste fitting so that small parts cannot be lost.

Take care not to drop accessories or tools into basin or bath.

⚠ CAUTION ⚠

Check there are no hidden cables or pipes before drilling holes for wall plugs.
Exercise great care when using power tools near water.
The use of a residual current device (RCD) is recommended.

13. COMMISSIONING THE SHOWER

IMPORTANT: This MX Thermostatic shower unit incorporates a commissioning procedure detailed below. It is important that this procedure is followed.

1. Make sure that the electricity supply has been isolated at the double pole isolating switch.
2. Ensure that the water supply is fully on at the mains stop cock and isolating service valve (if fitted)
3. Check that water is not leaking from the bottom of the case.
4. Switch on the electrical supply at the double pole switch or pull cord. The power on neon indicator will light at the switch.
5. On the shower unit press and hold the warmer (+) and cooler (-) buttons for a minimum of 3 seconds until COLD water flows into the shower and through to the shower handset, and then release the buttons. When the water is free flowing and all the air has purged through the system press the start / stop button and this will stop the water flow.
7. Press the start / stop button, you will hear a single bleep and the water will flow freely within a few seconds. The water flow will start at maximum flow indicated by 3 LEDs around the flow button.

NOTE: If the commissioning procedure is not used the heaters will have a 6 second delay before they are energised to allow the water to fill the unit (this only happens on the first start up operation).

IMPORTANT: If the button does not respond ensure that the flying lead from the PCB has been connected to the back of the front cover. Ensure front cover is isolated at the mains supply before removing.

9. The “Secret Until Illuminated” seven segment display will activate and show digit 8 for the Thermostatic Care model which indicates the FIXED pre-programmed start up temperature. The Thermostatic Plus models are supplied with MEMORY start up temperature setting which will be as per the last shower, however it may be necessary to adjust to digit 8 at initial start up. On all models the flow starts at the maximum level clearly indicated by the 3 illuminated LEDs.
10. The shower will start to heat the water. A double bleep indicates when the pre-programmed start up temperature has been reached. Please note this could take up to 30 seconds if the shower is starting from cold. The unit will automatically adjust the water flow if required.
11. Check the operation of the temperature control buttons by pressing the cooler (-) button once. The temperature digit will change to show 7 confirmed by a single bleep (if audio not de-selected on installation).

Keep pressing the cooler button repeatedly until the digit reaches 1, which when stable will give a nominal outlet temperature of 30°C.



IMPORTANT



The shower unit must be full of water before heat settings are used.

COMMISSIONING THE SHOWER (CONT.)

Now press the warmer (+) button repeatedly until the digit reaches 9 which when stable, will give a maximum outlet temperature of 41 °C for Care models and 47 °C for Plus models by default. If Maximum Temperature PROGRAMME 2 has been selected on installation this will be 43 °C. This could take up to 30 seconds if the shower is starting from cold. The unit will automatically adjust the water flow if required.

The maximum temperature lock LED will be illuminated when Maximum Temperature PROGRAMME 1 or 2 is set.

IMPORTANT: If the selected flow is high and the unit cannot reach the temperature selected the motorised flow control valve will automatically be adjusted to allow the unit to maintain the outlet temperature selected. Alternatively medium or low flow could be selected for economy and the thermostatic unit will maintain the temperature selected.

12. Press the start /stop button to switch the unit off. A single bleep will sound and initiate the PHASED SHUT DOWN operation.

PHASED SHUT DOWN

The Phased Shut Down operation is activated when the shower is stopped using the start /stop button. It switches the heating elements OFF but allows the

water to run for approximately 6 seconds taking the residual heat away from the elements and giving a cool start up for the next user.

1. The seven segment display shows this operation by counting down the horizontal bars 3–2–1–OFF



- 2.** Switch off pull cord or wall mounted switch
- 3.** Finally we recommend that the shower head is removed to make sure no debris has worked into it and the inlet water filter is checked and cleaned of any debris from the incoming pipe work. Clean and re-fit (see section 16 for cleaning instructions).
- 4.** Make sure that the water supply is fully turned ON.

BEAB CARE INSTALLATIONS

IMPORTANT: Additional checks and records are required for a BEAB Care installation. Please refer to the separate commissioning and in-service guide for full details.



Always use the start /stop button to switch the shower OFF. If the pull cord or surface mounted isolator is used to stop the shower without first pressing the start /stop button then you will by pass the phased shut down mechanism

14. OPERATING THE SHOWER

1. Switch on the electrical supply at the pull cord or wall mounted switch. The **power on** neon will illuminate indicating the switch is on.
2. Please do not stand under the spray from shower handset as initially the water will be cold. Press the shower start /stop button for immediate water flow. This is confirmed with a single audible bleep.
3. The “Secret Until Illuminated” seven segment display will activate and show through the front cover – displaying the FIXED pre-programmed start up temperature of digit 8 for Thermostatic Care models or the MEMORY start up temperature for the Thermostatic Plus. The unit will indicate the start up temperature has been reached by **sounding a DOUBLE bleep**.
4. The shower outlet temperature will increase until it reaches this pre-determined temperature. This could take up to 30 seconds if the shower is starting from cold.
5. The flow control will indicate the water flow through the shower:

3x LEDs illuminated: MAXIMUM flow
2x LEDs illuminated: ECO flow
1x LED illuminated: MINIMUM flow
6. The maximum temperature lock LED will be illuminated when Maximum Temperature PROGRAMME 1 or 2 is set. PROGRAMME 1 is the factory default setting on Care models where the maximum outlet temperature is limited to a nominal 41 °C. This feature is included for additional safety for use in the care sector, less able or by the extended family.

The LED will also be illuminated if PROGRAMME 2 has been selected on installation which limits the maximum outlet temperature to a nominal 43 °C.

NOTE: The “Secret Until Illuminated” seven segment display indicates the shower outlet temperature where 0 is cold, digit 1 represents a nominal 30 °C and digit 9 represents the maximum temperature:

PROGRAMME 1: a nominal 41 °C
(the default setting for Care models)

PROGRAMME 2: a nominal 43 °C

PROGRAMME 3: a nominal 47 °C
(the default setting for Plus models)

7. The shower outlet water temperature will be controlled thermostatically during the shower. If you wish to change this temperature then make adjustments described below.

TO INCREASE THE TEMPERATURE

1. Press the warmer (+) button **ONCE**. The digit will move, for example from 6 to 7 confirmed by a single audible bleep. The water temperature will increase by a nominal 1.5–2 °C. Wait a few seconds for the shower to increase the temperature to the new setting.
2. Repeat this if necessary to achieve your ideal temperature setting waiting each time for the new temperature to be achieved.

NOTE: If digit 9 is displayed by the seven segment temperature display then it will NOT be possible to request a higher outlet temperature as this is limited by the PCB control for additional safety.

OPERATING THE SHOWER (CONT.)

TO DECREASE THE TEMPERATURE

1. Press the cooler (-) button **ONCE**. The digit will move, for example from 6 to 5 confirmed by a single audible bleep. The water temperature will decrease by a nominal 1.5–2 °C. Wait a few seconds for the shower to reduce the temperature to the new setting.
2. Repeat this if necessary to achieve your ideal temperature setting waiting each time for the new temperature to be achieved.

FLOW CONTROL ADJUSTMENT

The push button flow control allows the water flow through the shower to be reduced or increased. Only occasional adjustment will be required.

To change the flow rate press the flow button in the appropriate place as indicated by the LEDs (confirmed with a single bleep). The flow will reduce or increase (depending on the setting) and will be indicated by the number of LEDs lit.

Please note: If the selected flow is high and the unit cannot reach the temperature selected the motorised flow control valve will automatically reduce the flow to allow the unit to reach and maintain the outlet temperature selected. Alternatively the

medium or low flow can be chosen for comfort and economy.

Switch the shower off by pressing the start / stop button. A single bleep will sound and initiate the **PHASED SHUT DOWN** operation. The water will run for approximately 6 seconds and then stop taking the residual heat away from the elements and giving a cool start up for the next user.

IMPORTANT: Always use the start / stop button to switch the shower off. If the pull cord or surface mounted isolator is used to stop the shower without first pressing the start / stop button then you will bypass the phased shut down mechanism.

The seven segment display shows this operation by counting down the horizontal bars 3–2–1–OFF.



Finally switch OFF at the pull cord or wall mounted isolating switch.

ATTENTION!

DO NOT OPERATE THE SHOWER UNIT IF THE SHOWERHEAD OR HOSE BECOMES DAMAGED.

THE SHOWER IS DESIGNED AND APPROVED TO EN-60335 WITH THE SHOWERHEAD PROVIDED. UNDER NO CIRCUMSTANCES MUST ANY SHOWERHEAD THAT IS NOT APPROVED BY THE MANUFACTURER BE USED WITH THIS PRODUCT.

15. HOW YOUR SHOWER WORKS

1. The cold incoming water is heated instantaneously as it flows over the heaters in the heat exchanger assembly.
2. At start up the seven segment display will activate and display the outlet temperature digit. For units with a temperature start function set to FIXED (Thermostatic Care in factory default state), digit 8 (nominal 40°C) will be displayed. For units set to MEMORY temperature start function (Thermostatic Plus by default) the last used temperature digit will display. A double bleep confirms to the user when the outlet temperature has been reached.
3. The built in motorised flow valve allows for automatic water flow control ensuring thermostatic operation at all times.
4. When a maximum temperature programme function is set, the maximum temperature lock LED will illuminate showing that this feature is active.
5. When pressing the warmer (+) and cooler (-) push buttons the water temperature set point is adjusted automatically by the electronic control and the seven segment display will move one digit higher or lower.
6. The amount of hot water available at the set temperature is limited by the total power of the heater.
7. Audible bleep feedback to all push button command is included (unless de-selected at installation).
8. The water is turned on and off by the solenoid valve built into the shower activated by the start / stop push button on the front cover.
9. The water flow, inlet and outlet water temperatures are measured and monitored to provide information to the control PCB at all times the shower is operating.
10. A stabiliser built into the water flow valve automatically compensates for small fluctuations in water pressure that frequently occur in households. There are three further controls that cater for exceptional restrictions in water pressure to prevent the shower from getting too hot.
 - a. If the water flow is less than 2L/min the power to the elements is switched off but the solenoid remains on allowing water to flow through the unit.
 - b. If the outlet water temperature reaches a level of 10°C above the limit set by the maximum temperature lock programme the heating elements and water solenoid are switched off giving full shower shut down for ultimate user protection. The display will show “o –t” (over temperature). See 12 below for further details.
 - c. A two stage mechanical cut-out is mounted on top of the heat exchanger independent of the electronic controls. Stage 1 switches the power off to the elements if it senses an excessive temperature. The switch operates with an audible click and will re-set if cold water is run through the shower. Stage two only operates if an extreme temperature is sensed. The cut-out will permanently switch off and will then have to be replaced. Due to the

HOW YOUR SHOWER WORKS (CONT.)

electronic control capability of the shower it is most unlikely that this device will operate.

11. A pressure relief device is fitted to safeguard against a build up of pressure in the heater. It provides protection to the heater should an excessive build up of pressure occur. If this device operates then a replacement part will be required.
12. If the shower has shut down as described in 10b above the shower unit will remain locked out until the water outlet temperature of the shower falls to 37°C. This could take some time as water will not be flowing.

Alternatively follow the procedure detailed below:

- Ensure that the water supply is back to normal.
- Stand clear of the shower.
- Press the warmer (+) and cooler (-) buttons together for more than 3 seconds.
- The water solenoid will energise and allow cold water to flow into the shower and purge the hot water out of the heat exchanger.
- Press the start/stop button to switch the unit off.
- Press the start/stop button and the unit will re-start and normal showering can be commenced.

16. ROUTINE MAINTENANCE

SHOWER HANDSET AND INLET WATER FILTER CLEANING INSTRUCTIONS

The shower handset should be cleaned periodically to remove lime scale or debris which will reduce the performance of the shower. The frequency of the cleaning will vary according to local water quality.

PERIODICAL MAINTENANCE

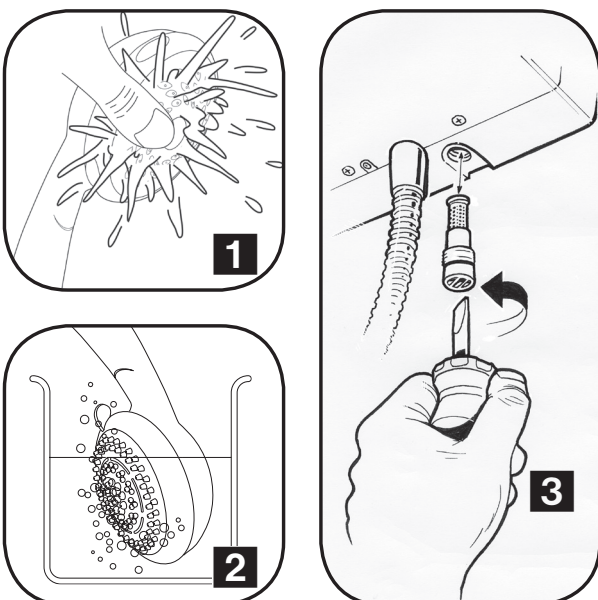

1. To break away scale deposits on a daily basis simply rub your thumb over the surface whilst the shower is running.
2. If scale deposits are stubborn, soak the showerhead in a proprietary limescale remover and rinse thoroughly before use.
3. Remove the filter from the bottom of the shower clean out any debris by washing in clean water. Refit filter.

17. TROUBLESHOOTING AND FREQUENTLY ASKED QUESTIONS

If the performance of your shower deteriorates in service please follow the self help items detailed below before seeking professional advice from the installer.

If the actions below fail to restore the shower performance you should initially contact the person or company that installed the shower.

Q. Water does not flow when start /stop button is pressed.

A. Seven things to check:

- Check the mains circuit breaker and/or fuse.
- Check the isolation pull cord or surface mounted switch is on.
- Check the mains water supply is fully open at the stop cock.
- Check that the local isolating valve is fully open.
- Check the inlet filter on the shower is not blocked (see page 25).
- If the “o –t” digits flash in the display the unit is in over temperature mode, if the water ceases to flow then the unit has automatically shut down.

PURGING INSTRUCTIONS: It is important to stand clear of the spray from the handset as hot water will initially be emitted.

- On the shower unit press and hold the warmer (+) and cooler (-) buttons for a minimum of 3 seconds until COLD water flows into the shower and through to the shower handset.
 - When the water is free flowing and all the air has purged through the system press the start /stop button and this will stop the water flow.
-

Q. Water too HOT.

A. Five possible reasons:

- Select a cooler temperature by pressing the cooler (-) button.
 - Clean the shower handset of any dirt or debris.
 - Check that the mains water stop valve is fully on.
 - Check the inlet filter on the shower (see page 25)
 - Check that the local isolating valve is fully open.
-

Q. Water too COLD.

A. Five things to check:

- Select a warmer temperature by pressing the warmer (+) button.
 - Confirm that there is sufficient water pressure and flow available.
 - Check to see if the “o –t” digits are showing in the display (see page 24).
 - If there is still no hot water contact MX Customer Care.
-

Q. Power setting reduces automatically.

A. This is part of the shower units thermostatic control operation and is a safety feature to reduce the risk of scalding. This is most likely caused by low water flow. See ‘Water too HOT’.

TROUBLESHOOTING AND FREQUENTLY ASKED QUESTIONS

Q. Temperature output is limited.

A. To maintain BEAB Care performance for additional user safety, Thermostatic Care units have the maximum outlet temperature factory set and limited to a nominal 41 °C.

The Thermostatic Plus models are supplied with the maximum outlet temperature limited to a nominal 47 °C.

Maximum outlet temperature options can be selected via dip switches mounted on the display PCB. This should be completed at installation by the installer as described on page 16.

Q. Spray pattern from the handset is poor.

A. Clean the spray nozzles or Select a different spray mode by rotating the spray plate.

Q. The shower switches off too quickly.

A. The shower timed operation is set too low. See changing the shower operational programmes on page 16. This should be carried out by the installer at installation.

Q. Shower runs on for about 6 seconds after pressing start /stop button then switches OFF.

A. This is normal. Unit is in automatic phased shutdown mode indicated by the horizontal bars in the display counting down, 3–2–1–OFF. This feature ensures a cool start up temperature for the next user.

Q. Water is dripping from the bottom of the shower.

A. Safety pressure relief may have operated. This will need to be replaced. Please contact the MX service line.

Check the inlet mains water connection.

If the pressure relief valve has operated check the hose and handset are NOT partially or fully blocked. These would need to be replaced. Please contact the MX service line.

Q. The shower filter and/or the handset keeps blocking or filling up with solid material.

A. Following the initial installation no solid materials should remain in your cold water supply or the electric shower unit. There is a problem with your water supply. Contact a plumber for advice.

Q. The shower hose or shower hand set become damaged or is leaking.

A. Contact MX Customer Care and they will advise of a suitable replacement.

Q. My electric shower is out of the warranty period and is no longer working.

A. Please contact MX Customer Care for advice.

Customer Care Department
Telephone: 0845 505 2211 Fax: 0845 850 0757
9.00 am – 5.00 pm Monday to Friday

18. TROUBLESHOOTING CHECKLIST FOR THE INSTALLER

IMPORTANT: The following check list is provided for the benefit of the qualified installer.

WARNING: SWITCH OFF THE ELECTRICITY AT THE ISOLATOR BEFORE REMOVING THE FRONT COVER TO MAKE CHECKS.

Q. Shower switches off too quickly.

A. Shower timed operation has been set too low. See changing the shower programmes on page 16.

Q. Poor temperature control.

A. Check the inlet and outlet thermistors to see if they are in circuit.

Check for blockage in the inlet filter (see page 25).

Q. Water too cold.

A. Check the circuit through the thermal cut out.

Check circuit through all 3 elements.

NOTE: Test to be done using a low voltage resistance meter whilst the power is switched OFF at the isolating switch.

Check working voltage.

Q. Poor or no control over water flow.

A. Replace the water flow valve head works.

Q. No water when start /stop button is pressed.

A. Check the water supply isolating valves are fully open.

Check circuit through the solenoid coil.

Q. Pressure relief valve operated.

A. Check for cause of high pressure such as blocked shower hose or shower handset. Replace pressure relief valve disc. (Note: this is not covered under the product guarantee.)

Q. Temperature output is limited.

A. To maintain BEAB Care performance for additional user safety, Thermostatic Care units have the maximum outlet temperature factory set and limited to a nominal 41 °C.

The Thermostatic Plus models are supplied with the maximum outlet temperature limited to a nominal 47 °C.

Maximum outlet temperature options can be selected via dip switches mounted on the display PCB. This should be completed as described on page 16.

Customer Care Department

Telephone: 0845 505 2211

Fax: 0845 850 0757

**9.00 am – 5.00 pm
Monday to Friday**

19. THE MARLETON CROSS LTD (MX GROUP) – 2 YEAR GUARANTEE

Marleton Cross Limited (MX Group) hopes you are satisfied with your purchase and in the unlikely event that you encounter a problem which is caused exclusively by the MX Group manufactured product (the “**product**”) we will take responsibility on the terms set out here.

We aim to supply components which have been manufactured to the highest standards. In respect of the product you have a two year guarantee which covers any defect in manufacture.

Any part found to be defective during the guarantee period will be replaced without charge providing that the product has been installed in accordance with our instructions, used as intended and maintained/serviced as recommended.

In the unlikely event that any problems are encountered with this component’s performance on installation, please contact our Customer Care Department for help, as below.

Please supply proof and date of purchase when contacting MX Group.

The company reserves the right, in the event of a claim not covered by the guarantee, to charge the claimant for parts and labour at current rates. This guarantee is given in addition to and does not affect your statutory rights.

Exclusions:

1. Any product found to be defective during this period, as the result of misuse, neglect or damage, will not be covered by this guarantee such as:
 - Damage caused by accident
 - Those components subject to wear and tear such as ‘O’ rings and washers etc.
 - Effects of scaling
 - Damage caused by faulty installation.
 - Damage caused by waterborne debris.
 - Damage caused by improper cleaning components.
 - The components being used for a purpose other than intended.
2. Breakdown due to:
 - a) Use other than domestic use by you or your resident family
 - b) Wilful act or neglect
 - c) Any malfunction resulting from the incorrect use or quality of water or incorrect setting of controls; and
 - d) Faulty installation.
3. Repair costs for damage caused by foreign objects or substances or the inappropriate use of jointing compounds or blow torches.
4. Total loss of the product due to non-availability of parts or other reason, (MX Group will maintain stocks of spare parts for repair for at least 5 years from end of product line to cover this guarantee).
5. Compensations for loss of use of the product or consequential loss of any kind.

THE MARLETON CROSS LTD (MX GROUP) – 2 YEAR GUARANTEE

6. Call out charges
7. The cost of routine maintenance, adjustments, overhaul modifications or loss or damage arising there from, including the cost of repairing damage, breakdown, malfunction caused by corrosion, furring, pipe scaling, limescale, system debris or frost.
8. Components and/or units including components purchased and installed other than in the United Kingdom.

Limitations

1. This guarantee lasts for a single continuous period of 2 years from the date of delivery to you the customer.
2. This guarantee is personal to the original purchaser of the product and is not transferable.
3. Original proof of purchase(s) must be shown for any claim under this guarantee.
4. This guarantee does not cover any components that have been modified, altered or transformed in any way.
5. This guarantee applies to an original installation in accordance to our fitting instructions and does not cover previously installed components (showroom displays etc) or components that have been moved from their original installation position for any reason.
6. This guarantee applies only to manufacturing or material defects. It does not apply to normal wear and tear, accidental damage, inappropriate use (including inappropriate cleaning) or other events outside the manufacturer's control.
7. This guarantee applies only to the product itself and as a result any liability attributed to MX Group is limited to the cost of the component.
8. If a product is deemed to be of faulty manufacture MX Group will at their discretion replace the component. Any related consequential loss or damage is excluded.
9. No claim will be accepted if a product is installed with a fault (ours or otherwise) that would have been clearly evident before installation.
10. We make no representations, and exclude any and all liability, in respect of any third party products or services supplied by way of extensions to this guarantee.

Liability

1. Except as required or agreed by us, you will not in any circumstances return any of the product to us, and where the property in any of the goods returned to us has passed to you, they will nevertheless remain your property and at your risk unless we have agreed otherwise in writing before their return.
2. Except as stated above, we will not be liable for any direct, consequential or other loss, damage or injury suffered or incurred by you, and you will indemnify us fully against any claims made by third parties, in respect of the goods or otherwise arising from the contract.

THE MARLETON CROSS LTD (MX GROUP) – 2 YEAR GUARANTEE

3. Nothing contained in the contract will be treated as excluding or restricting any liability on our part for death or personal injury resulting from our negligence.
4. Except as stated above, and to the fullest extent permitted by law, all conditions, warranties and representations, whether express or implied, statutory or otherwise in relation to the product (other than such as relate to title to the component) are excluded.
5. You acknowledge that our prices for the goods reflect these Terms and Conditions, and accordingly that you accept the above limitations on and exclusions of liability in exchange for those prices.
6. When providing information to MX-Group you understand that you are doing this subject to our terms and other policies (including data protection) we have in place from time to time, copies of which are available on our website www.mx-group.com or on request as per the MX Group contact details given herein.
7. This guarantee does not affect your statutory rights.

In the interest of continuous product development we reserve the right to alter the specification as necessary.

In the unlikely event that you need to make a claim on our guarantee please contact MX Customer Care on 0845 505 2211 or sales@mx-group.com

20. SERVICE POLICY

In the event of you needing to contact the MX Group Customer Care Department, the following procedure should be followed:-

1. Before telephoning the MX Group Customer Care Department you should ensure that you have the model number, power rating, serial number, this can be found on the bottom of the shower unit plus the date of purchase.
2. The MX Group Customer Care Department will be able to inform you whether the fault can be rectified by the provision of a replacement part or an on site visit by a Qualified Service Engineer.
3. If a service call is booked, you or a representative must be present during the Engineers visit.
4. A charge will be made where a call under the terms of the guarantee has been booked and a failure was not product related, or an engineer arrives and is not able to gain access.
5. If the product is no longer covered by the Guarantee, a charge will be made for the site visit and for any parts supplied.

Customer Care Department

Telephone: 0845 505 2211 Fax: 0845 850 0757

9.00 am – 5.00 pm Monday to Friday

655NN RN/MAY2015



Marleton Cross Limited Trading as The MX Group

Alpha Close, Delta Drive, Tewkesbury Industrial Estate, Tewkesbury, Gloucestershire GL20 8JF
Tel: 01684 293311 Fax: 01684 293900 Email: sales@mx-group.com www.mx-group.com

CUSTOMER CARE: 0845 5052211

TRADE DESCRIPTIONS ACT

Variations in terms of colour finish, materials and all other aspects of appearance may occur on occasions, either through non-availability of materials or due to our policy of continuing technical improvement. Therefore the Company reserves the right to change specification or withdraw products from this list without prior notice being given.