

E-Tec Better



INSTALLATION INSTRUCTIONS

Please follow these care instructions to ensure your product retains its high quality finish and please retain this leaflet for future reference.

The shower spray head *MUST* be cleaned regularly to remove scale and debris. The frequency of the cleaning will vary according to the local water quality. If the water outlet temperature becomes hot and you are unable to obtain cooler water, immediately check the shower handset for blockage.

Do not operate shower if frozen, or suspected of being frozen. It must thaw out before using.

MAINS SERVICE CONNECTIONS: The shower unit is supplied for right entry and left entry.

IMPORTANT: To comply with water regulations, building regulations or any specific local water company regulations and in accordance with BS EN 806 a double check valve should be fitted where it is possible that the shower head may come into contact with used water, for example in the bath or a shower tray.

IMPORTANT: Check that there are no hidden cables or pipes before drilling holes for the wall plugs. Choose a flat piece of wall to avoid the possibility of distorting the back plate and making the front cover a poor fit. Exercise great care when using power tools near water. The use of a residual current device (RCD) is recommended.

IMPORTANT: Before connecting the water supply to the shower unit the water supply pipe should be flushed out to remove all debris. After flushing the pipework make the connection to shower inlet and ensure the shower is positioned squarely on the wall and all fixing screws are tightened.

IT IS VERY IMPORTANT: To ensure that the terminal block screws are fully tightened and that no cable insulation is trapped under screws, and tighten periodically in accordance with BS 7671. The earth continuity conductor of the electrical installation must be effectively connected to all exposed metal parts of other appliances and services in the room in which the shower unit is installed to conform with BS 7671. The unused supply terminal block must not be used for any other purpose.

IMPORTANT: Ensure that the temperature control knob is turned to MIN temperature (FULL flow) and the commissioning instructions are followed before switching the unit on. This will make sure that the unit is full of water when first activated.

IMPORTANT: The shower unit **MUST** be full of water before the heat settings are changed.

IMPORTANT: The shower unit **MUST** be fitted with a WRAS (Water Regulations Advice Scheme) listed mains water isolating valve.

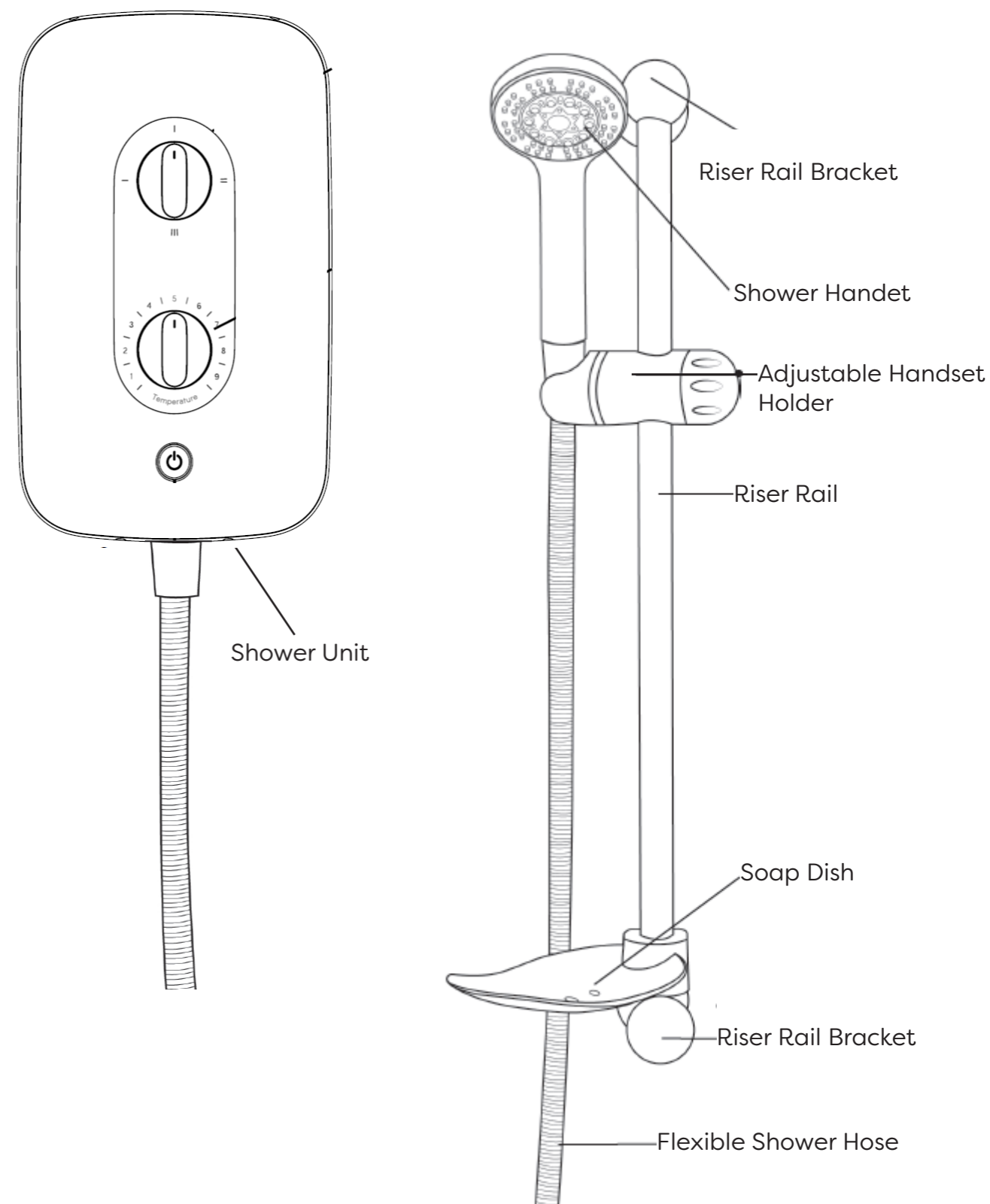

Shower installation must be carried out by a suitably qualified person and be in accordance with BS 7671 (IET wiring regulations), building regulations, water regulations and / or any specific local water company regulations in force and should be in accordance with BS EN 806.

A double check valve must be fitted with all flexible shower accessories where it is possible that the shower handset may come into contact with used water i.e. In the bath or shower tray.

Shower Unit Installation

Position your shower on a FLAT section of wall, ensuring that it will NOT be in the direct water spray from the shower handset when fixed. The shower unit should be positioned so that the shower handset cannot be immersed in the bath or shower tray when hanging down. When you have found the ideal position for the unit remove the four front cover fixing screws and lift the cover off complete with the control knobs and start /stop push button.

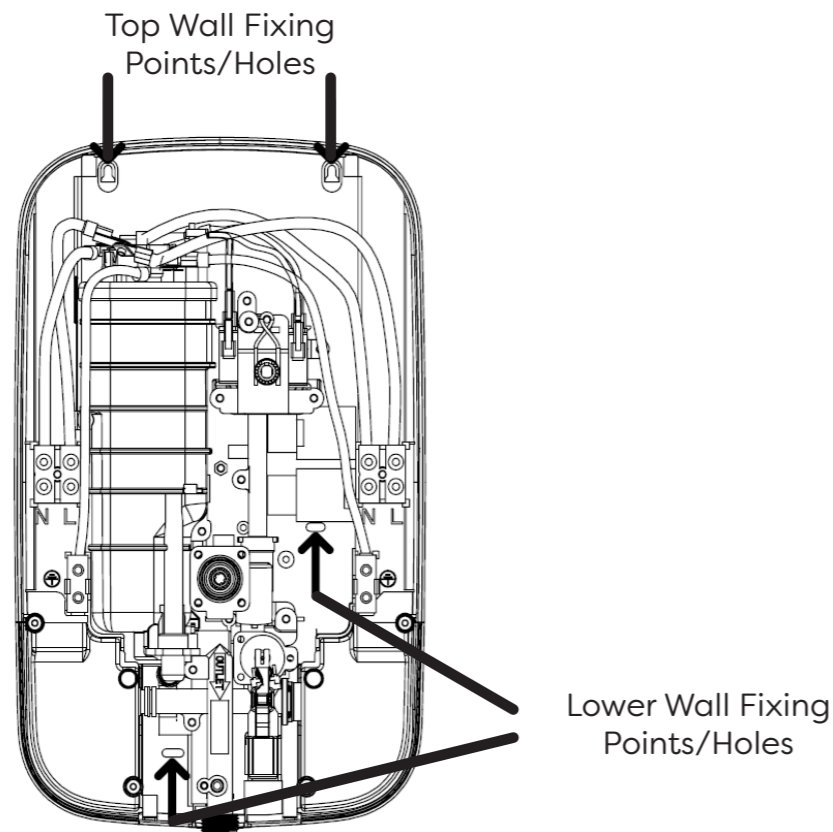

- Having decided on the water and cable entry points (and chosen a flat piece of wall), hold the shower vertically against the wall and mark the top two fixing holes whilst ensuring the shower is square.
- Carefully drill the two holes as marked using a sharp 5.5mm masonry drill after first making certain there are no pipes or wires behind the proposed holes.
- Insert the wall plugs and screws provided leaving the screw head proud by approximately 5mm. The shower can now be hung on these screws.
- Make sure that the shower is positioned vertically and square, now mark and drill the lower slotted fixing hole. Then fix the shower to the wall. Do not fully tighten the screws at this stage
- The shower back plate and removable corner mouldings have moulded cut out sections which are clearly indicated to allow the chosen service entry option to be cut out prior to final fix.

IMPORTANT: Before connecting the mains water supply to the shower flush out the pipe work to remove all swarf and system debris. This is achieved by connecting a suitable hose (i.e. Garden hose) to the pipe work and turning on the mains water supply at the isolating stop tap long enough to clear the debris to waste.

On the shower unit, the back plate incorporates removable corners on the lower left and right side to allow for easy access when deciding on and connecting the water mains supply.

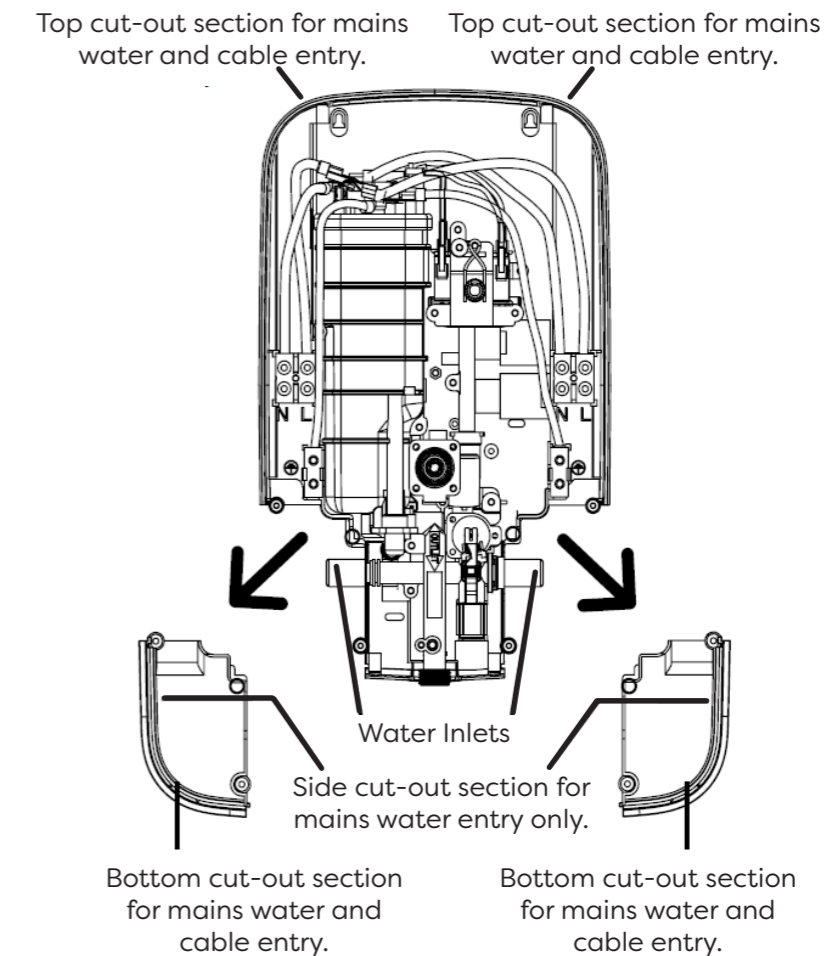

- Before connecting the water supply to the unit, turn off the mains water supply at the isolating stop tap
- Having decided on the direction of the water inlet supply: Top (falling) Bottom (rising) or rear /side inlet, it is necessary to remove the appropriate knock out (thinned out plastic) cross section from the back plate before commencing with the installation. The connection to the unit is made using a 15mm copper, stainless or plastic pipe with a 15mm compression elbow or 15mm push fit elbow.
- If **left hand water entry** is desired, remove spring clip and then blanking cap. Replace blanking cap onto right spigot, ensuring it is fully seated, then snap spring clip back into groove for retainment. Tighten the back plate fixing screws so the unit is firmly fixed to the wall.
- If **rear entry pipe** work is used we recommend the use of a suitable sealant to seal around the incoming pipe work to prevent water entering the wall.
- Turn on the mains water supply and check for leaks, paying particular attention to the water inlet connections. **At this stage no water can flow through the unit.**

Electrical Connection

The electrical installation must be in accordance with the current BS 7671 (I.E.T. wiring regulations) and part P of the building and / or local regulations.

The shower unit must be permanently connected to the electrical supply, direct from the consumer unit via an electrical isolation switch with a minimum contact gap of 3 mm. The switch must be readily accessible and clearly identifiable and sited out of reach of a person using the shower over a fixed bath or shower tray, unless the switch is pull cord operated. The wiring must be connected to the switch without the use of a plug or socket outlet.

- The incoming cable should be hidden. Connect as follows:

Earth cable to terminal marked 

Neutral cable to terminal marked **N**

Live cable to terminal marked **L**

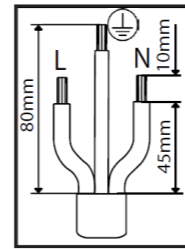

- The outer sheath of the supply cable must be stripped back to a suitable length and the earth conductor must have an earthing sleeve fitted.
- Connect the cable to the terminal block. Ensure that ALL the retaining screws are VERY tight and that NO cable insulation is trapped under the screws. Loose connections can result in cable overheating.

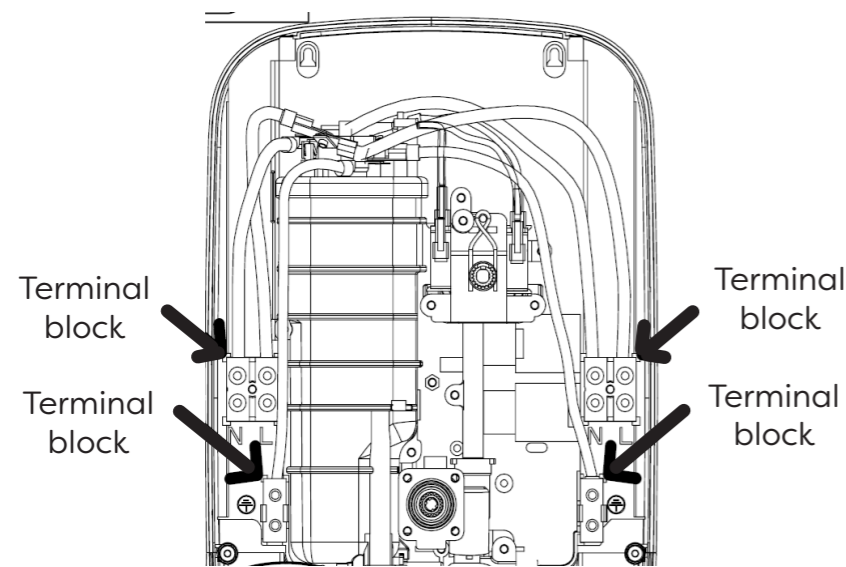

IMPORTANT: Failure to ensure that the retaining screws are **VERY** tight could result in a failure of the terminal block.

IMPORTANT: DO NOT switch on the electricity supply until the shower cover has been fitted.

IMPORTANT: Follow these cut back cable guidelines, to ensure the product has a reliable electrical connection.

IMPORTANT: The unused supply terminal block must not be used for any other purpose.

Re-attaching the front cover

IMPORTANT: It is essential that the control knobs on the cover are aligned with the opposite control spindles mounted on the back plate before the front cover is fitted and that the sealing cord should be located in groove.

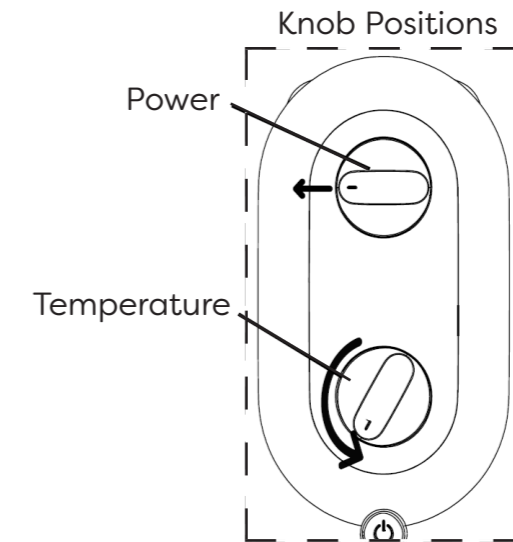

- First turn the power selector knob; identified by the solid blue line, to the **cold** position.
- Then turn the temperature control knob **anti-clockwise** to the mechanical stop position (minimum temperature).
- On the shower back plate make sure that the power selector spindle key way is pointing **LEFT** and the temperature spline spindle is rotated fully anti-clockwise until it reaches the mechanical stop.
- Remove instruction card from spindle. The front cover can now be fitted carefully ensuring the controls are aligned and secured with the four fixing screws provided.

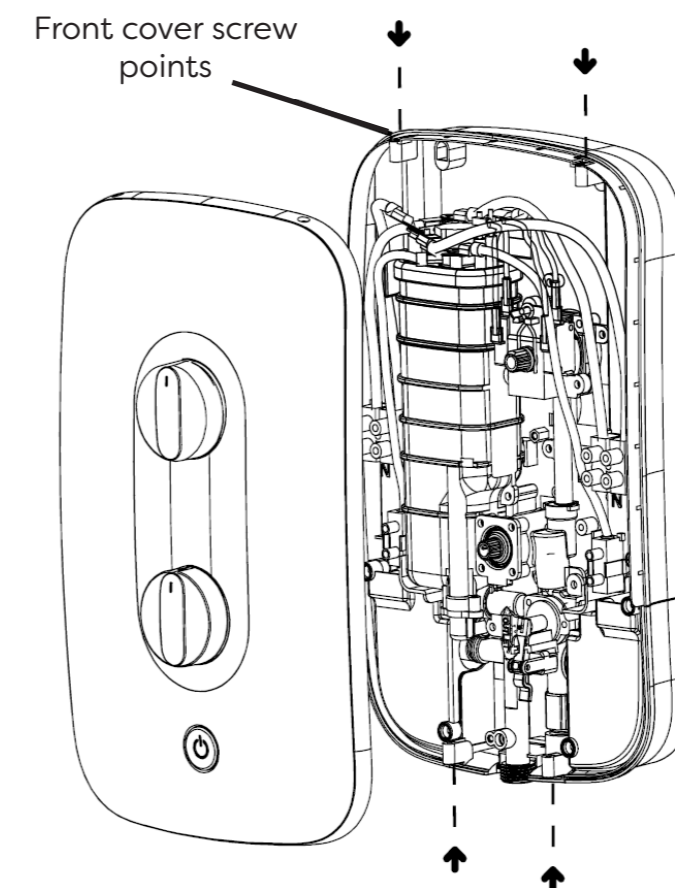

Riser Rail Fitting Instructions

First Use Of The Shower

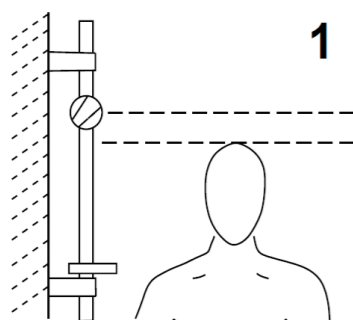

1

Establish position for the riser rail, and mark the wall for the lower mounting bracket. Make allowances for the tallest person likely to use the shower regularly.

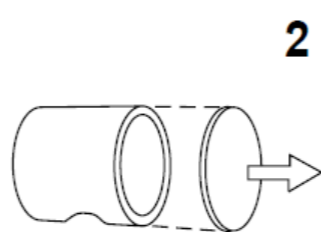

2

Remove covers from the wall brackets.

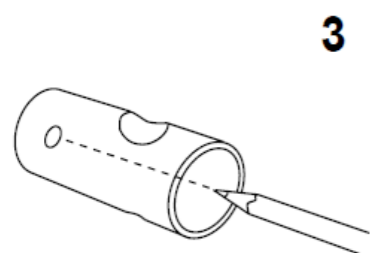

3

Position the top bracket and mark the wall for the screw fixing. Drill, plug the wall and fix the top bracket.

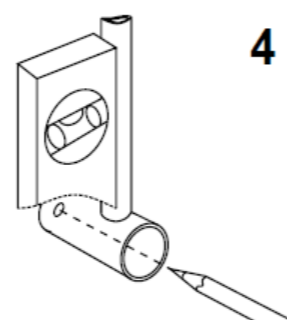

4

Fit the rail into the top bracket. Place the remaining bracket onto the rail. Ensure the rail is vertically aligned and mark the wall. Remove the rail and bracket, then drill and plug the wall.

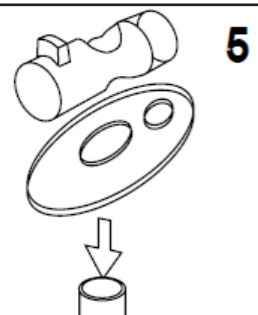

5

Slide the height adjuster onto the rail, release mechanism with push button. Then fit the soap dish, dampening the rail will make it easier to slide on.

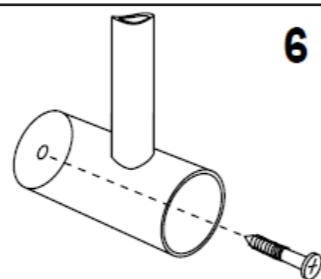

6

Replace the rail assembly into the top bracket. Refit the bottom bracket, ensuring the larger rail hole is facing outwards and fix to the wall.

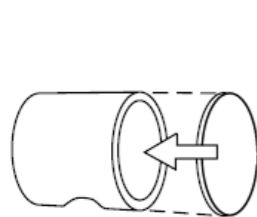

7

Snap covers over both brackets.

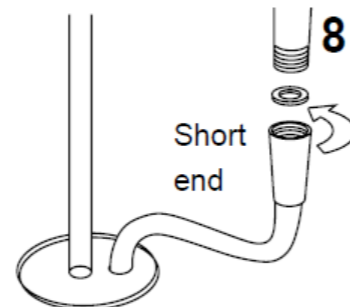

8

Firmly attach shorter conical end of flexible hose to shower handset making sure sealing washer is in place after first passing through the hose retaining ring with no kinks.

1. Turn the top rotary power selector knob; identified by the solid blue line, to the Cold setting.
2. Turn the rotary temperature control fully anti-clockwise to the minimum temperature position (direction of blue graphic).
3. Ensure that the water supply is fully on at the mains stop cock and isolating service valve.
4. Check that water is not leaking from the bottom of the case.
5. Push the start/stop button and check that water flows freely from the shower within a few seconds. At this point the water from the shower handset will be at full force and at a cool temperature.
6. Slowly rotate the bottom temperature control knob to the maximum temperature position (fully clockwise). This will gradually reduce the flow of water through the shower. The water temperature will remain cool.
7. Return the temperature knob to the minimum temperature position (fully anti-clockwise).
8. Switch on the electrical supply isolation switch.
9. Now turn the top power selector knob to the Eco 1 power setting indicated by one solid red line. Allow a few seconds for the warmer temperature to reach the shower head. This shows that the Eco 1 power setting is working correctly.
10. Now turn the top power selector to the high power setting indicated by three solid red lines. The temperature should rise further. This shows that the full power setting is working correctly.
11. Now adjust the bottom rotary temperature control knob clockwise for hotter water allowing a few seconds for the temperature to stabilize. Set the control to a comfortable showering temperature slowly.
12. Push the start / stop button to switch the unit off.
13. Switch off at the electrical isolation switch.
14. Finally we recommend that the shower head is removed to make sure no debris has worked into it. Clean and re-fit.

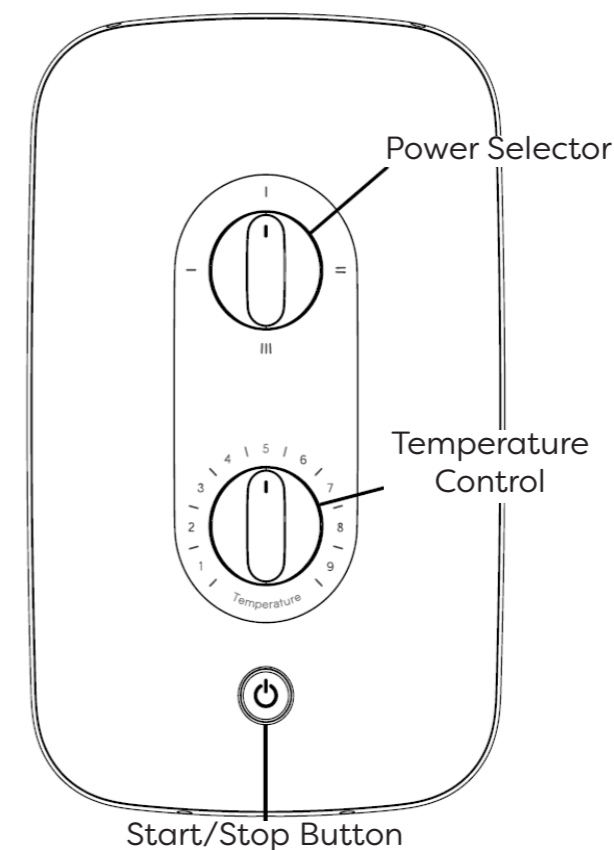

Shower Operation

1. Switch on the electrical supply at the isolation switch.

NOTE: We recommend that you do not stand under the spray from the shower handset when switching on – wait until the water has reached a stable warm temperature.

2. Push the start/stop button for immediate water flow.

3. Select your power setting using the top rotary control. There are four power settings:

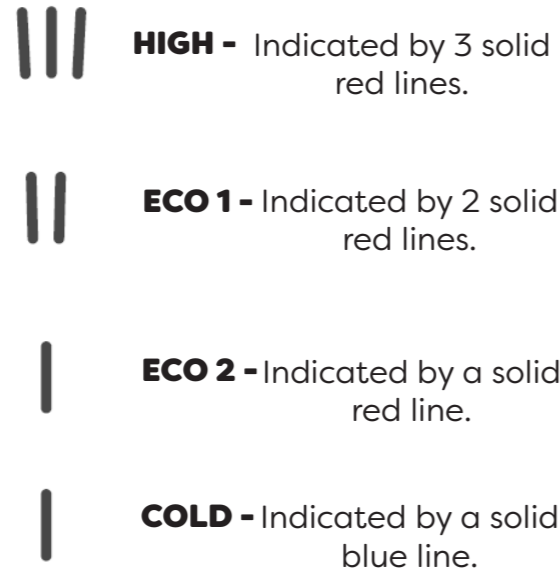

4. The temperature control knob alters the outlet temperature by increasing or reducing the flow rate of water through the shower unit.

5. To increase the temperature turn the control knob clockwise (towards 9) and this will decrease the flow. To reduce the temperature turn the control knob anti-clockwise (towards 1) and this will increase the flow.

6. To turn off the shower

7. Finally switch off electricity supply at the isolation switch.

Maintenance

Shower head

The shower handset should be cleaned periodically to remove lime scale or debris which will reduce the performance of the shower. The frequency of the cleaning will vary according to local water quality.

Filter Cleaning

It is recommended that the filter is periodically cleaned in order to maintain the performance of the shower. It is essential that this operation is carried out by a competent person.

Important - Before servicing, switch off the electricity supply at the isolation switch.

- Switch off the mains water supply at the isolation valve.
- The inlet filter is situated inside the water inlet housing.
- To gain access unscrew the filter cap from the bottom of the inlet housing.
- Inspect O-ring for damage when the filter cap is removed.
- To reassemble, follow procedure in reverse.
- DO NOT over tighten the filter cap on reassembly.

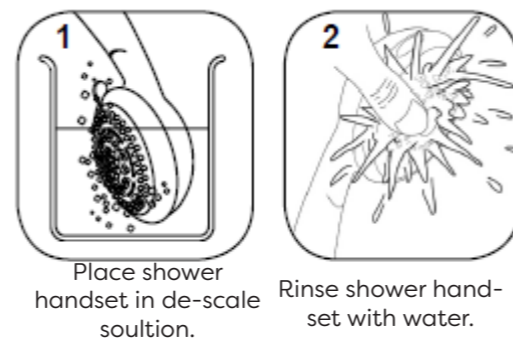

Troubleshooting & Frequently Asked Questions

IMPORTANT: If the issue requires removal of front cover, please seek help of qualified person.

Q. Water does not flow when start/stop button is pressed.

1. Check the mains water supply is fully open at the isolation valve.
2. Check that the mains water supply is turned on at the isolation valve.
3. Check that the front cover is correctly mounted on the back plate and all cover-screws are fitted correctly.

Q. Water too HOT.

1. Reduce the temperature by adjusting the rotary temperature control.
2. Clean the shower handset of any dirt or debris.
3. Check that the mains water isolation valve is fully open.
4. Check that the local isolating valve is fully open.
5. Select a lower power setting.
6. Clean inlet filter of any dirt or debris.

Q. Water is dripping from the bottom of the shower.

- A. Safety pressure relief may have operated. This will need to be replaced. Check the inlet mains water connection. If the pressure relief valve has operated check the hose and handset are NOT partially or fully blocked. These would need to be replaced.

Q. The shower cycles from hot to cold.

- A. The shower temperature is set too hot causing the thermal cut-out (safety device) to operate. Turn temperature control knob anti-clockwise to increase water flow. Then slowly increase the water temperature by turning temperature control knob clockwise until a comfortable showering temperature has been reached. You MUST WAIT approximately 20-30 seconds for each adjustment to affect the water temperature. 'ECO' setting may need to be selected.

Q. Water too COLD.

1. Check the mains circuit breaker and/or fuse.
2. Check that the electrical isolation switch is turned on
3. Check the rotary power selector is set to high power (indicated by three solid red lines).
4. Increase the water temperature by adjusting the rotary temperature control in the direction of the red graphic.
5. Confirm that there is sufficient mains water pressure.
6. Restart the shower on the high power setting.
7. Allow cold water to run through the shower to re-set the cyclic over temperature cut-out.

Q. Spray pattern from the handset is poor.

- A. Clean the spray plate. If the handset is adjustable select a different mode by rotating the spray plate

Q. The shower filter and/or the handset keeps blocking or filling up with solid material.

- A. Following the initial installation no solid materials should remain in your cold water supply or the electric shower unit. There is a problem with your water supply. Contact a plumber for advice.