

Mira Reflex

Thermostatic Bar Valve

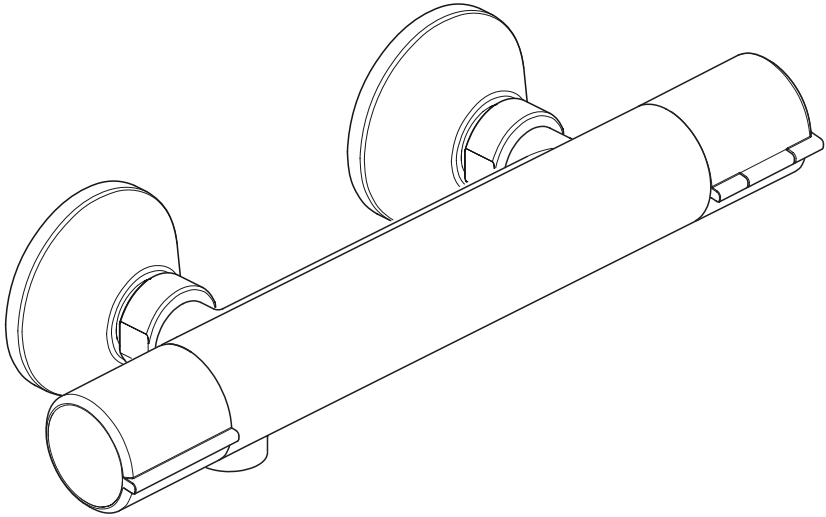

These instructions must be left with the user

Installation & User Guide

Showering perfection

mira
SHOWERS

INTRODUCTION

Thank you for purchasing a quality Mira product. To enjoy the full potential of your new product, please take time to read this guide thoroughly, having done so, keep it handy for future reference.

The Mira Reflex thermostatic bar valve is a thermostatic shower control designed for wall mount installations.

The thermostatic bar valve has two knobs, one knob controls the flow and the other knob controls the temperature.

The thermostatic bar valve incorporates a wax capsule temperature sensing unit, which provides an almost immediate response to changes in pressures or temperature of the incoming water supplies, to maintain the selected temperature. An adjustable maximum temperature stop is provided which limits the temperature to a safe level. Inlet filters are fitted to protect the thermostatic cartridge.

Guarantee

For **domestic installations**, Mira Showers guarantee the Mira Reflex against any defect in materials or workmanship for a period of **three** years from the date of purchase (shower fittings for one year).

If you experience any difficulty with the installation or operation of your new thermostatic mixer, please refer to **'Fault Diagnosis'**, before contacting Kohler Mira Ltd. Our contact details can be found on the back cover of this guide.

For non-domestic installations, Mira Showers guarantee the Mira Reflex against any defect in materials or workmanship for a period of one year from the date of purchase.

For terms and conditions refer to the back cover of this guide.

Recommended Usage

Application	Valve with Fittings
Domestic	✓
Light Commercial	✓
Heavy Commercial	✗
Healthcare	✗

Design Registration

GB 001225254-0003

SAFETY WARNINGS

The function of a thermostatic mixing valve is to deliver water consistently at a safe temperature. In keeping with every other mechanism, it cannot be considered as functionally infallible and as such, cannot totally replace a supervisor's vigilance where that is necessary. Provided it is installed, commissioned, operated and maintained within manufacturers recommendations, the risk of failure, if not eliminated, is reduced to the minimum achievable.

Mira thermostatic mixers are precision engineered and should give continued safe and controlled performance, provided:

1. They are installed, commissioned, operated and maintained in accordance with the manufacturer's recommendations.unstable blend temperatures.

2. Periodic attention is given, when necessary, to maintain the product in good functional order.

Caution!

1. Read all of these instructions.
2. Retain this guide for later use.
3. Pass on this guide in the event of change of ownership of the installation site.
4. Follow all warnings, cautions and instructions contained in this guide.
5. Anyone who may have difficulty understanding or operating the controls of any shower should be attended whilst showering. Particular consideration should be given to the young, the elderly, the infirm or anyone inexperienced in the correct operation of the controls.
6. Children should be supervised to make sure that they do not play with the appliance.
7. Care is required when adjusting flow or temperature, make sure that the temperature has stabilised.
8. If pipework and/or electrical cables enter the shower from the rear through a hole in the wall, provision must be made to prevent water ingress back into the wall structure.
9. When this product has reached the end of its serviceable life, it should be disposed of in a safe manner, in accordance with current local authority recycling, or waste disposal policy.
10. Sunburn or skin conditions can increase your sensitivity to hot water. Make sure that you set the shower to a cooler temperature.

PACK CONTENTS

Tick the appropriate boxes to familiarise yourself with the part names and to confirm that all of the parts are included.

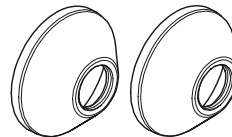
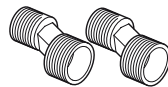
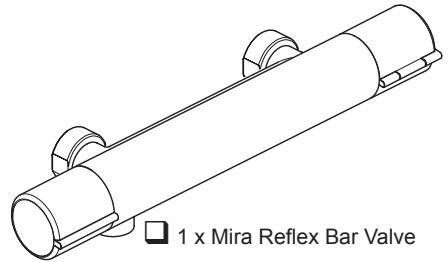

Documentation

- 1 x Guarantee Registration Document

SPECIFICATIONS

Pressures

- Max Static Pressure: **10 Bar**.
- Max Maintained Pressure: **5 Bar**.
- Min Maintained Pressure: (Gas Water Heater): **1.0 Bar** (for optimum performance supplies should be nominally equal).
- Min Maintained Pressure (Gravity System): **0.1 Bar** (0.1 bar = 1 Metre head from cold tank base to showerhead outlet).

Temperatures

- Close temperature control is provided between **20°C and 50°C**.
- Optimum Thermostatic Control Range: **35°C to 45°C** (achieved with supplies of 15°C cold, 65°C hot and nominally equal pressures).
- Recommended Hot Supply: **60°C to 65°C** (**Note!** The mixing valve can operate at temperatures up to 85°C for short periods without damage. However for safety reasons it is recommended that the maximum hot water temperature is limited to 65°C).
- Minimum Differential between Hot Supply and Outlet Temperature: **12°C at desired flow rates**.
- Minimum hot water supply temperature: up to **55°C**.

Thermostatic Shut-down

- For safety the thermostat will shut off the hot supply **within 2 Seconds** if the cold supply fails (achieved only if the hot supply temperature is greater than 10°C above the set blend temperature).

Connections

- **Hot: Left** (side nearest flow control), ½" BSP Male.
- **Cold: Right** (side nearest temperature control), ½" BSP Male.
- **Outlet:** bottom, ½" BSP Male to flexible hose.

Note! This product does not allow for reversed inlets and will deliver unstable temperatures if fitted incorrectly.

Offset connector (inlet centres are 150 mm ± 24 mm).

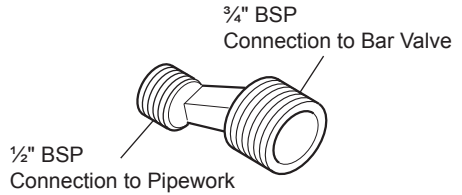

DIMENSIONS

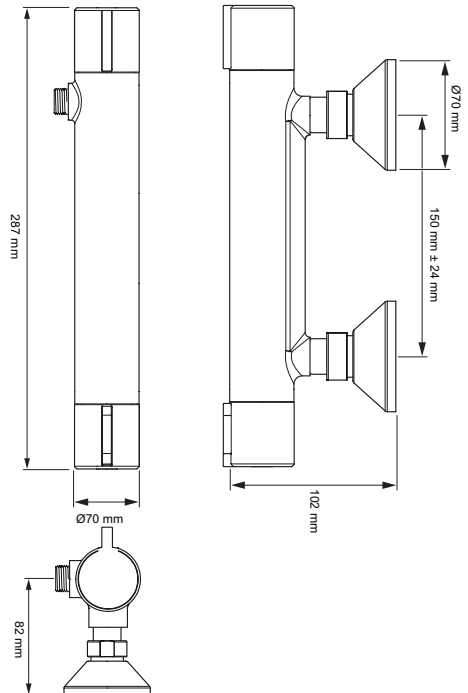

INSTALLATION

Suitable Plumbing Systems

Gravity Fed:

The thermostatic mixer must be fed from a cold water cistern (usually fitted in the loft space) and a hot water cylinder (usually fitted in the airing cupboard) providing nominally equal pressures.

Gas Heated System:

The thermostatic mixer can be installed with a combination boiler.

Unvented Mains Pressure System:

The thermostatic mixer can be installed with an unvented, stored hot water system.

Mains Pressurised Instantaneous Hot Water System:

The thermostatic mixer can be installed with systems of this type with balanced pressures.

Pumped System:

The thermostatic mixer can be installed with an inlet pump (twin impeller). The pump must be installed on the floor next to the hot water cylinder.

General

Installation must be carried out in accordance with these instructions, and must be conducted by designated, qualified and competent personnel.

The installation must comply with the "Water Supply Regulations 1999 (Water Fittings)" or any particular regulations and practices, specified by the local water company or water undertakers.

Note! Make sure that all site requirements correspond to the information given in section: '**Specifications**'.

1. The mixer must not be installed in an area where it may freeze.
2. For stud partitions alternative fixings may be required.
3. Isolating valves must be installed close to the mixer for ease of

maintenance.

4. Pipework must be rigidly supported and avoid any strain on the connections.
5. Pipework dead-legs should be kept to a minimum.
6. Decide on a suitable position for the mixer. The position of the mixer and the shower fittings must provide a minimum gap of 25 mm between the spill-over level of the shower tray/bath and the showerhead (refer to illustration). This is to prevent back-siphonage.
Note! Only use shower fittings recommended by the manufacturer or supplier.
7. All pipework must be checked for leaks before the product installation is completed. The product should be pressurised & the inlet & outlet connections inspected.

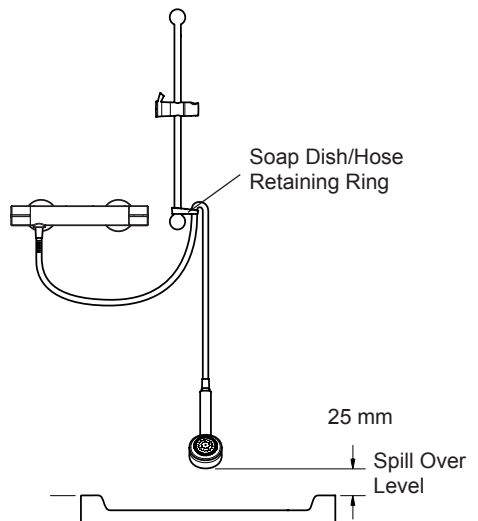

Installing the Thermostatic Mixer

The thermostatic bar valve should be installed where it will be supported by fixed pipework. For unfixed pipework a wall mounting bracket must be used (available as a spare part, part number: 1663.257, contact Customer Services).

1. Install the pipework, making sure that it is set at the correct distance apart (150 ± 24 mm) **and solidly fixed**.
2. Apply suitable thread sealant (not supplied) and attach the offset connectors to the pipework in the wall. The offset connectors must protrude between 35 and 40 mm from the finished wall.

Note! Connections are: **Hot-Left, Cold-Right**. This is very important as this product does not allow for reversed inlets.

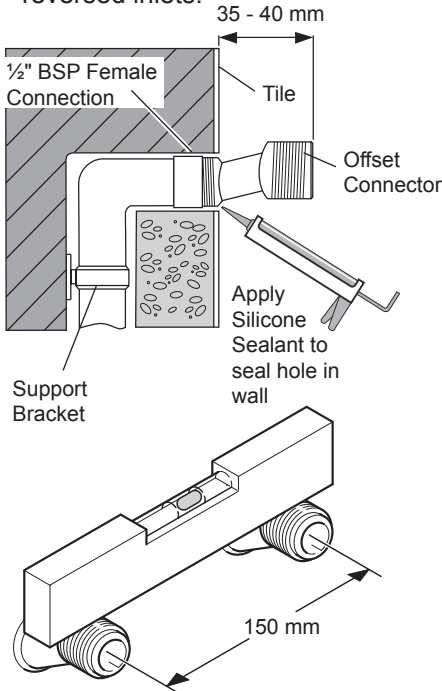

3. Tighten the offset connectors using a spanner on the spanner flats. Make sure that the connectors are level and set at the correct distance apart, using the bar valve as a guide to spacing.

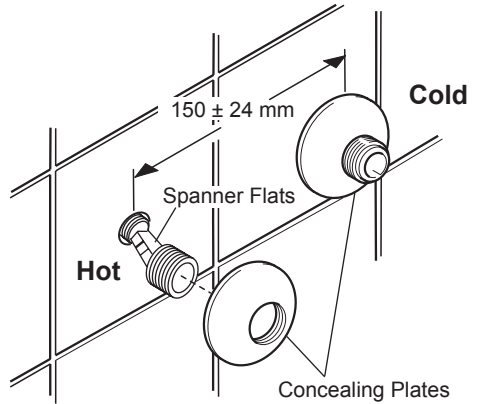

4. Screw the concealing plates onto the offset connectors until they come into contact with the wall.
5. **Caution!** Make sure that the supply pipework is flushed before installing the Bar Valve.

Assemble the bar valve with a sealing washer/filter in each inlet and attach to the offset connectors.

Note! Connections are: **Hot-Left, Cold-Right**.

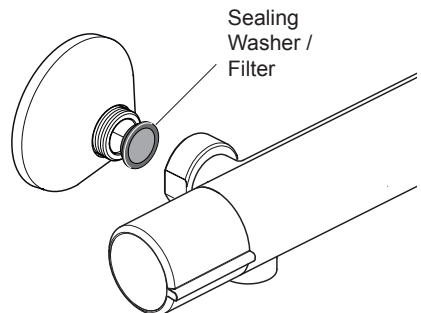

6. Tighten the connections using a suitable spanner.
7. Install the shower fittings, refer to the shower fittings Installation and User Guide.
8. Turn on the hot and cold water supplies and check for leaks.
9. Before using the shower, refer to section: 'Commissioning'.

COMMISSIONING

Maximum Temperature Setting

Before using the shower the maximum temperature must be checked to make sure that it is at a safe level. It has been preset to a safe showering temperature under ideal conditions at the factory, appropriate for most systems. However, site conditions and personal preference may make it necessary to reset this temperature.

Note! Make sure that the hot water temperature is at least 55°C and that there is sufficient supply.

Caution! Before testing the mixer, make sure that the hot and cold water is flowing correctly by exercising the temperature selector knob between the cold and hot stops.

1. Turn the temperature selector knob to override and test that the temperature of the water from the shower outlet is hot enough.
2. If not, depress the override button and **carefully** rotate the knob. If the water temperature is still not hot enough complete the following procedure.
3. Rotate the temperature selector knob back to the override position.

4. Using a suitable screwdriver carefully pry off the concealing cap and unscrew the fixing screw.
5. Pull off the temperature selector knob without disturbing the stop assembly.
6. Replace the temperature selector knob so that the override knob is at the 1 O'clock position.
7. Rotate the temperature selector knob against the stop, wait for the water to stabilise and test that the temperature of the water from the shower outlet is hot enough.
If the water temperature is still not hot enough repeat the procedure until a maximum safe temperature is achieved at the override position.
8. Refit and tighten the fixing screw, refit the concealing cap.

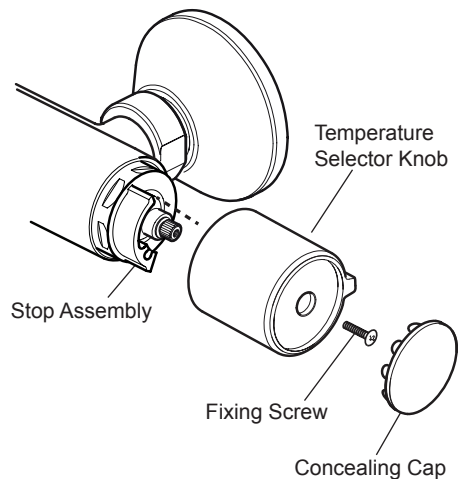

OPERATION

Adjusting the Temperature

The temperature is controlled by rotating the temperature selector knob (see below). For safety reasons, the temperature is limited by an override stop. To obtain a higher temperature, press the override button on the temperature selector knob and continue to rotate the knob.

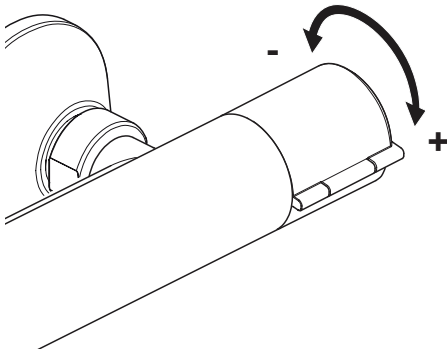

Adjusting the Flow

The flow is controlled by rotating the flow selector knob (see below).

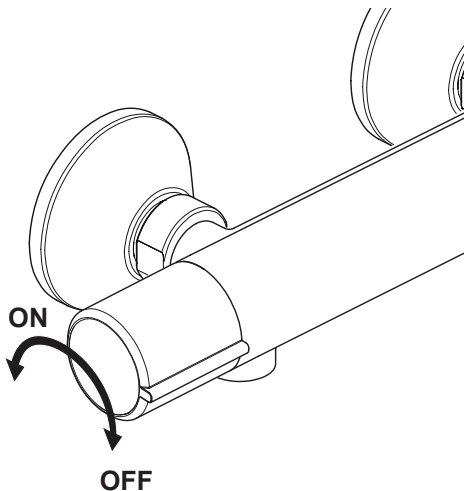

MAINTENANCE

If you require a Mira trained service engineer or agent, refer to section: 'Customer Services'.

Fault Diagnosis

Symptom:

- Only hot or cold water from the mixer outlet.
- Outlet temperature too hot / too cold.

Cause / Rectification:

- Inlets reversed (hot supply to cold supply). Rework inlet pipework.
 - No hot or cold water reaching the mixer.
 - Check the filters for any blockage.
 - Installation conditions outside operating parameters, refer to sections: 'Specifications' and 'Commissioning'.
-

Symptom:

- Fluctuating or reduced flow rate.

Cause / Rectification:

- Check the showerhead, hose and filters for any blockage.
 - Make sure that the maintained inlet pressures are nominally balanced and sufficient, refer to section: 'Specifications'.
 - Make sure that the inlet temperature differentials are sufficient, refer to section: 'Specifications'.
 - Air lock or partial blockage in the pipework.
-

Symptom:

- *Water leaking from showerhead.*

Cause / Rectification:

- *Normal for a short period after shut off.*
- *Check that the pressures are not in excess of the specifications for the product.*
- *Cartridge inlet seals damaged, renew.*
- *Renew the thermostatic cartridge.*

Lubricants

Silicone based lubricants must only be used on the rubber seals.

Caution! Oil based or other lubricant types may cause rapid deterioration of seals.

Cleaning

The chrome plated parts should be cleaned using a mild washing up detergent or soap solution, rinsed and then wiped dry with a soft cloth.

Warning! Many household cleaners contain abrasive and chemical substances, and should not be used for cleaning plated or plastic fittings.

Do not use descalents on this product.

Filters

The sealing washers / filters are located in the inlet connector. Clean or renew as necessary.

Maintaining the Non-Return Valves

The non-return valves are located in the thermostatic bar valve body, and are accessible through the inlet connectors.

Caution! Make sure that the non-return valves are installed correctly to prevent crossflow or malfunction of the valve.

1. With the water supplies turned off and the thermostatic bar valve removed, remove the sealing washer / filter.
2. Unscrew the non-return valve housing using a 12 mm hexagonal wrench.

Note! The non-return valve housing has a **Left Hand Thread**, turn clockwise to unscrew.

3. Carefully remove the non-return valve and clean any debris.
4. On re-assembly make sure that the non-return valve is fitted the correct way round (with the arrow indicating the flow pointing towards the valve).

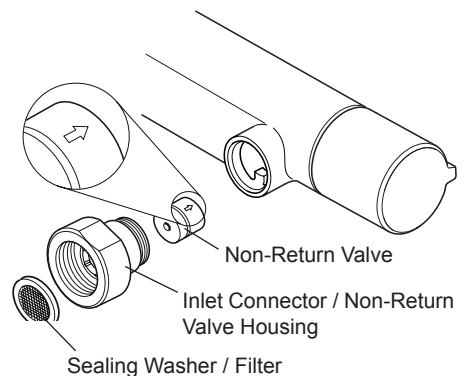

SPARE PARTS

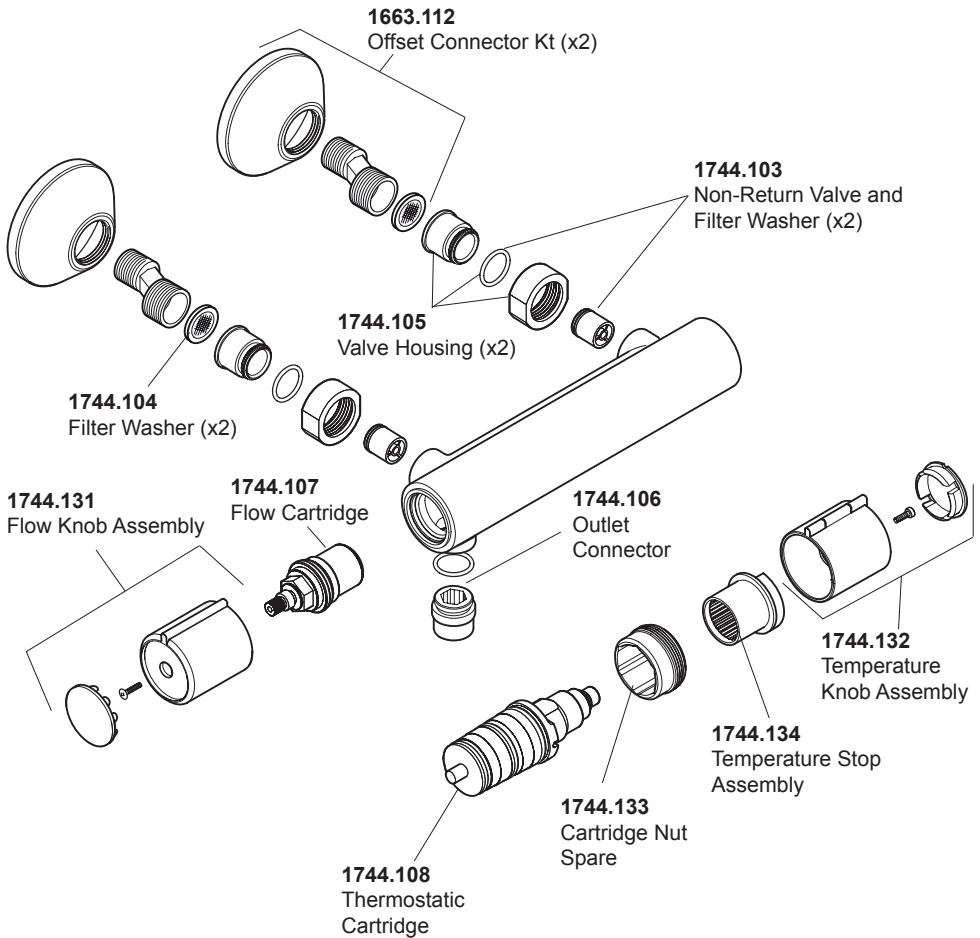

Note! All spare parts are supplied individually unless stated otherwise.

CUSTOMER SERVICE

Guarantee

Your product has the benefit of our manufacturer's guarantee which starts from the date of purchase.

To activate this guarantee, please return your completed registration card, visit our website or free phone 0800 0731248 within 30 days of purchase (UK only).

Within the guarantee period we will resolve defects in materials or workmanship, free of charge, by repairing or replacing parts or product as we may choose.

This guarantee is in addition to your statutory rights and is subject to the following conditions:

- The guarantee applies solely to the original installation under normal use and to the original purchaser only. The product must be installed and maintained in accordance with the instructions given in this user guide.
- Servicing must only be undertaken by us or our appointed representative. **Note!** if a service visit is required the product must be fully installed and connected to services.
- Repair under this guarantee does not extend the original expiry date. The guarantee on any replacement parts or product ends at the original expiry date.
- For shower fittings or consumable items we reserve the right to supply replacement parts only.

The guarantee does not cover:

- Call out charges for non product faults (such as damage or performance issues arising from incorrect installation, improper use, inappropriate cleaning, lack of maintenance, build up of limescale, frost damage, corrosion, system debris or blocked filters) or where no fault has been found with the product.
- Water or electrical supply, waste and isolation issues.
- Compensation for loss of use of the product or consequential loss of any kind.
- Damage or defects caused if the product is repaired or modified by persons not authorised by us or our appointed representative.
- Routine maintenance or replacement parts to comply with the requirements of the TMV2 or TMV3 healthcare schemes.
- Accidental or wilful damage.
- Products purchased ex-showroom display

What to do if something goes wrong

If your product does not work correctly refer to this manual for fault diagnosis and check that it is installed and commissioned in accordance with our instructions. If this does not resolve the issue, contact us for help and advice.



Helpdesk Service - Ring our Customer Services Team for product advice, to purchase spare parts or accessories or to set up service visit. You can contact us via phone or e-mail, details below. Please provide your model name, power rating (if applicable) and date of purchase.



Mira Showers Website (www.mirashowers.co.uk)

Visit our website to register your guarantee, download user guides, diagnose faults, purchase our full range of accessories and popular spares, or request a service visit.



Spares and Accessories - We hold the largest stocks of genuine Mira spares and accessories. Contact us for a price or visit our website to purchase items from our accessory range and popular spares.



Service/Repairs - No one knows our products better than our nationwide team of Service Technicians. We can carry out service or repair work to your product both during and after the guarantee period. Ask about our fixed price service repairs.

To Contact Us: UK



0844 571 5000



Fax: 01242 282595



E-mail: Visit www.mirashowers.co.uk/contactus



Mira Customer Services Dept, Cromwell Road, Cheltenham, Gloucestershire, GL52 5EP

To Contact Us: Eire Only



01 531 9337



E-mail: CustomerServiceEire@mirashowers.com

Mira is a registered trade mark of Kohler Mira Limited.

The company reserves the right to alter product specifications without notice.



mira
SHOWERS

CUSTOMER SERVICE

Guarantee

Your product has the benefit of our one year manufacturer's guarantee which starts from the date of purchase.

Within the guarantee period we will resolve defects in materials or workmanship, free of charge, by repairing or replacing parts or product as we may choose.

This guarantee is in addition to your statutory rights and is subject to the following conditions:

- The product must be installed and maintained in accordance with the instructions given in this user guide.
- Replacement under this guarantee does not extend the original expiry date. The guarantee on any replacement parts or product ends at the original expiry date.

The guarantee does not cover:

- Non product faults (such as damage or performance issues arising from incorrect installation, improper use, inappropriate cleaning, lack of maintenance, build up of limescale, frost damage, corrosion, system debris or blocked filters) or where no fault has been found with the product.
- Accidental or wilful damage.
- Compensation for loss of use of the product or consequential loss of any kind.
- Damage or defects caused if the product is repaired or modified by persons not authorised by us or our appointed representative.

What to do if something goes wrong

If your product does not function correctly when you first use it, check that it is installed and commissioned in accordance with the instructions in this manual.

If this does not resolve the issue, contact our Customer Services Team who will offer you or your installer help and advice.

If you experience problems, check in this manual to see if simple home maintenance is required. If you require further assistance call our Customer Services Team.

Helpdesk Service

Our Customer Services Team is comprehensively trained and can offer help and advice, spare parts and accessories. We will need you to have your model name or number and date of purchase. As part of our quality and training programme calls may be recorded or monitored.

Mira Showers Website (www.mirashowers.co.uk)

From our website you can download additional user guides, diagnose faults, purchase our full range of accessories and popular spares, refer to our FAQ's.

Spares and Accessories

We maintain extensive stocks of genuine spares and accessories and aim to provide support throughout the product's expected life.

Payment can be made by phone at time of order using most major Credit or Debit cards and we aim to despatch orders within 2 working days. Items purchased from us are guaranteed for 12 months from date of purchase.

Returns – items can be returned within one month of date of purchase, providing that they are in good condition and the packaging is unopened. If you wish to return any items please notify us in writing within seven days of receipt.

To Contact Us

UK

Telephone: 0844 571 5000

E-mail: technical@mirashowers.com

Fax: 01242 282595

By Post: Mira Customer Services Dept, Cromwell Road, Cheltenham, Gloucestershire, GL52 5EP

Eire

Telephone: 01 459 1344

E-mail: sales@modernplant.ie

Fax: Dublin 01 459 2329

By Post: Modern Plant Ltd (Dublin), Otter House, Naas Road, Clondalkin, Dublin 22

Mira L16E Shower Fittings

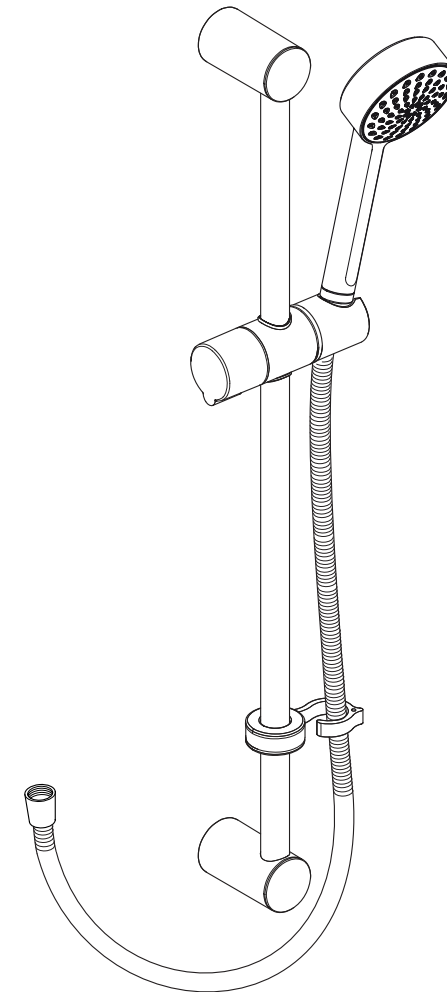

These instructions must be left with the user

Mira is a registered trade mark of Kohler Mira Limited.

The company reserves the right to alter product specifications without notice.

www.mirashowers.co.uk

Showering perfection

mira
SHOWERS

Installation & User Guide

Showering perfection

mira
SHOWERS

General

1. Make sure that the shower fittings are installed by a competent installer.
2. Installations must comply with Water Regulations (Bye-Laws, Scotland), and any other Local Regulations and Building Regulations in force at the time of installation.
3. The shower fittings should be positioned at a convenient height for all the family. Position the fittings to spray across rather than towards the opening of the cubicle and also away from the shower control. Avoid layouts where the shower hose will be sharply kinked. This may reduce the life of the hose.
4. A hose retaining ring is supplied to prevent the showerhead from dropping below the spill over level of the bath or shower, which could lead to contamination from back-siphonage.

The position of the shower and shower fittings must provide a minimum gap of 25 mm between the showerhead and the spill over level of any bath, shower tray or basin and 30 mm between the showerhead and the spill over level of any toilet or bidet.

5. Do not fit any form of flow control in the outlet pipe work if the shower fittings are installed in conjunction with a product that requires the fittings to act as a vent (e.g. an electric shower).
6. Special consideration should be given to the fixing arrangements when installing onto a dry lined, stud partition, shower cubicle or laminated panel wall structures. Installers may wish to obtain alternative proprietary cavity fixings, or choose other options, however, these methods of fixing are beyond the scope of this guide.

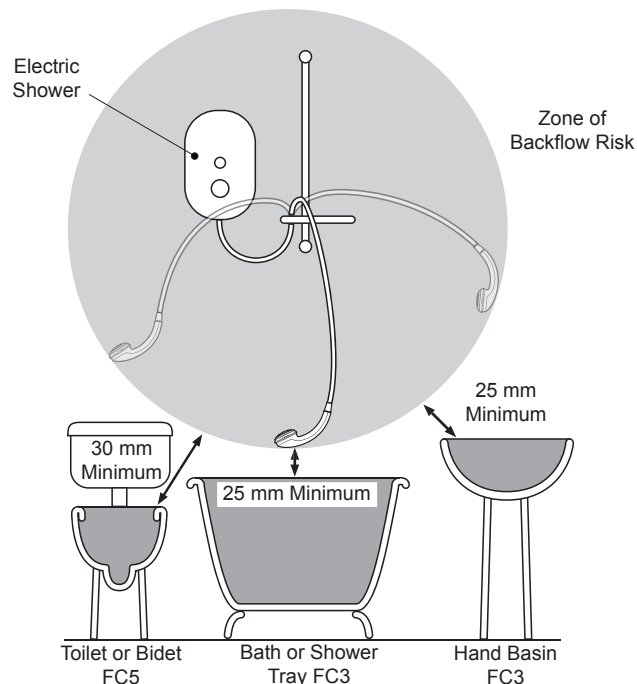

Hose Retaining Ring fitted and shower fittings fixed at a suitable height preventing dirty water backflow

Specification - Pressures

Minimum maintained pressure: 0.1 bar (10 kPa).

Maximum maintained pressure: 5.0 bar (500 kPa).

Installation

1. Decide on a suitable position for the shower fittings.
2. Place the bracket on the wall and mark the position of the fixing hole. Drill and plug the hole and fit the lower bracket to the wall.
3. Fit the slide bar in the lower bracket and fit the top bracket in position.
4. Mark the position of the fixing hole for the top bracket and remove it from the slide bar end. Drill and plug the hole.
5. Fit the hose retaining ring and the clamp bracket over the end of the slide bar.
6. Fit the top slide bar end and secure in position with the screw.
7. Fit the slide bar caps.

Hose and Showerhead Installation

1. Fit a hose seal into the conical nut and screw onto the outlet of the shower.
Caution! Do not over tighten.
2. Feed the hose through the hose retaining ring.
3. Fit a hose seal into the conical nut and screw onto the handset.
Caution! Do not over tighten.
4. Place the showerhead assembly into the clamp bracket assembly.

Cleaning

Many household cleaners contain abrasives and chemical substances, and should not be used for cleaning plated or plastic fittings. These finishes should be cleaned with a mild washing up detergent or soap solution, and then wiped dry using a soft cloth. Use your thumb or a soft cloth to wipe any limescale from the soft rubber nozzles and the front face of the spray plate assembly.

