

Mira Realm Thermostatic Mixer

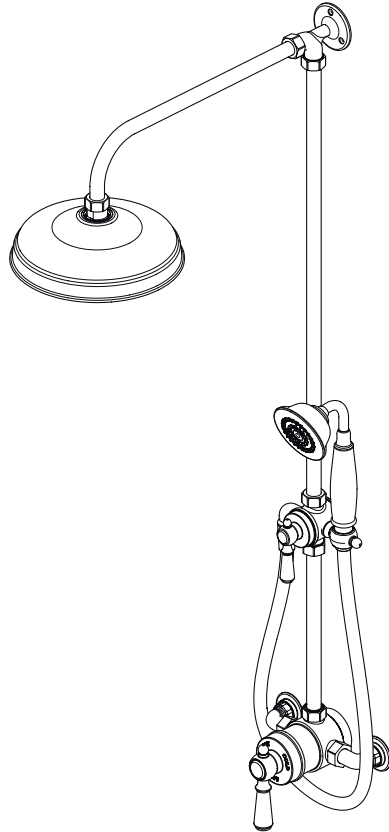
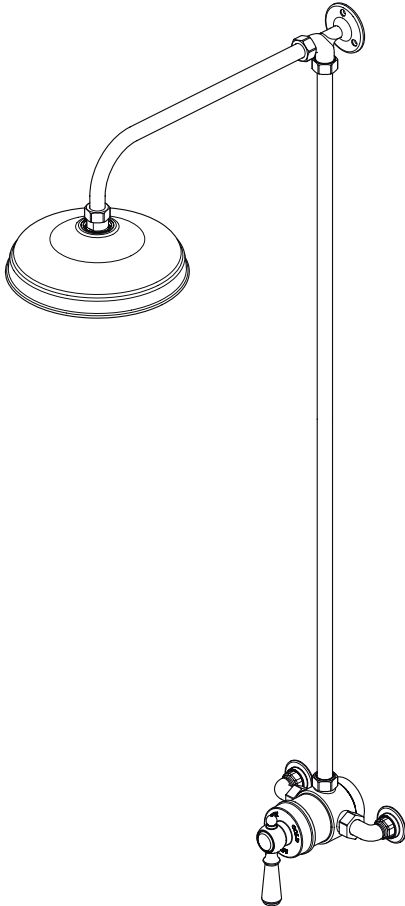

These instructions must be left with the user

Installation and User Guide

Showering perfection

mira
SHOWERS

CONTENTS

Introduction	2
Recommended Usage	3
Patents and Design Registration	3
Safety : Warnings	3
Pack Contents	4
Mira Realm	4
Mira Realm with Diverter	5
Specifications	6
Pressures	6
Temperatures	6
Flow Rates	6
Thermostatic Shut-down	6
Connections	6
Dimensions	7
Installation	8
Suitable Plumbing Systems	8
General	8
Mira Realm	9
Mira Realm with Diverter	11
Reversed Inlet Supplies	12
Operation	12
Mira Realm Mixing Valve	12
Mira Realm with Diverter	13
Commissioning	13
Maximum Temperature Setting	13
Fault Diagnosis	14
Fault Diagnosis	14
Maintenance	15
Spare Parts	16
Mira Realm	16
Mira Realm with Diverter	17
Accessories	18
Notes	19
Customer Service	20

INTRODUCTION

Thank you for purchasing a quality Mira product. To enjoy the full potential of your new product, please take time to read this guide thoroughly, having done so, keep it handy for future reference.

The Mira Realm thermostatic mixer is a thermostatic shower control with a single control lever for on/off and temperature control.

A 12 L/Min flow regulator is supplied for high pressure systems to reduce excessive shower force.

The thermostatic mixer incorporates a wax capsule temperature sensing unit, which provides an almost immediate response to changes in pressures or temperature of the incoming water supplies to maintain the selected temperature. An adjustable maximum temperature stop is provided which limits the temperature to a safe level. Inlet filters are fitted to protect the thermostatic cartridge.

Mira Realm: Thermostatic Mixer for connection to rising, falling or rear entry pipework, supplied with a deluge head.

Mira Realm with Diverter: Thermostatic Mixer for connection to rising or rear entry pipework, supplied with a diverter valve which gives the option of using the handset, deluge head or both.

Guarantee

For **domestic installations**, Mira Showers guarantee the Mira Realm against any defect in materials or workmanship for a period of **five** years from the date of purchase (shower fittings for one year).

For **non-domestic installations**, Mira Showers guarantee the Mira Realm against any defect in materials or workmanship for a period of **one** year from the date of purchase.

For terms and conditions refer to the back cover of this guide.

If you experience any difficulty with the installation or operation of your new thermostatic mixer, please refer to '**Fault Diagnosis**', before contacting Mira Showers. Our contact details can be found on the back cover of this guide.

Recommended Usage

Application	Valve with Fittings
Domestic	✓
Light Commercial	✓
Heavy Commercial	✗
Healthcare	✗

Patents and Design Registration

Patents:

GB: 2 291 693, 2 392 225, 2 422 886

Euro: 1 672 257 DE FR GB IT NL SE

USA: 7 240 850

Patent Applications:

Euro: 07015846.4

USA: 2006-0124758-A1, 2010-0219255-A1

6. Rapid/Excessive movement of the flow and/or temperature control levers may result in momentary unstable blend temperatures.
7. Care is required when adjusting flow or temperature, make sure that the temperature has stabilised.
8. When this product has reached the end of its serviceable life, it should be disposed of in a safe manner, in accordance with current local authority recycling, or waste disposal policy.
9. The function of a thermostatic mixing valve is to deliver water consistently at a safe temperature. In keeping with every other mechanism, it cannot be considered as functionally infallible and as such, cannot totally replace a supervisor's vigilance where that is necessary. Provided it is installed, commissioned, operated and maintained within manufacturers recommendations, the risk of failure, if not eliminated, is reduced to the minimum achievable.

SAFETY : WARNINGS

Mira thermostatic mixers are precision engineered and should give continued safe and controlled performance, provided:

1. They are installed, commissioned, operated and maintained in accordance with manufacturer's recommendations.
2. Periodic attention is given, when necessary, to maintain the product in good functional order.

Caution!

1. Read all of these instructions.
2. Retain this guide for later use.
3. Pass on this guide in the event of change of ownership of the installation site.
4. Follow all warnings, cautions and instructions contained in this guide.
5. Anyone who may have difficulty understanding or operating the controls of any shower should be attended whilst showering. Particular consideration should be given to the young, the elderly, the infirm or anyone inexperienced in the correct operation of the controls.

PACK CONTENTS

Tick the appropriate boxes to familiarise yourself with the part names and to confirm that all of the parts are included.

Mira Realm

- 4 x Compression Nuts (18 mm)
- 4 x Olives (18 mm)
- 2 x Compression Nuts (15 mm)
- 2 x Olives (15 mm)
- 5 x Wall Plugs
- 3 x Fixing Screws (Chrome - Wall Bracket)
- 2 x Fixing Screws
- 2 x Concealing Plates
- 1 x Flow Regulator & Adapter
- 1 x 2.5 mm Hexagonal Key
- 1 x 'O' Key
- 1 x Wall Bracket
- 1 x Shower Arm
- 1 x Rigid Riser
- 1 x Deluge Head
- 1 x Thermostatic Mixing Valve
- 1 x Cartridge Removal Tool

Documentation

- 1 x Guarantee Registration Document
- 1 x Installation Template

Mira Realm with Diverter

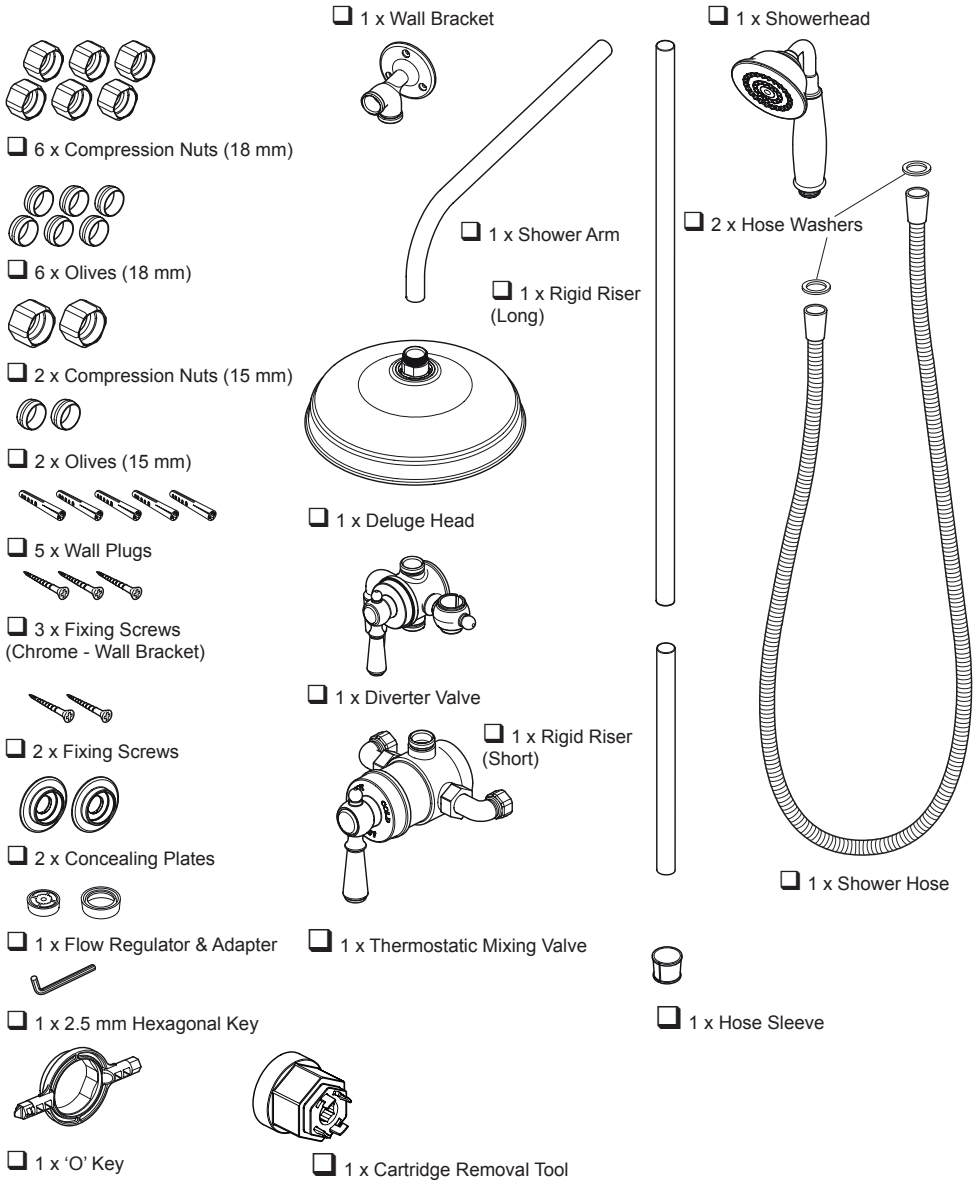

Documentation

- 1 x Guarantee Registration Document
- 1 x Installation Template

SPECIFICATIONS

Pressures

- Max Static Pressure: **10 Bar**.
- Max Maintained Pressure: **5 Bar**.
- Min Maintained Pressure (Gravity System): **0.1 Bar** (0.1 bar = 1 Metre head from cold tank base to showerhead outlet).
Note! For gravity fed or other low pressure systems (0.5 bar or below) do not fit the outlet flow regulator.
- For optimum performance supplies should be nominally equal.

Temperatures

- Factory Pre-set (Blend) Shower: **41°C**.
- Optimum Thermostatic Control Range: **35°C to 43°C** (achieved with supplies of 15°C cold, 65°C hot and nominally equal pressures).
- Recommended Hot Supply: **60°C to 65°C**
Note! The mixing valve can operate at higher temperatures for short periods without damage, however this could detrimentally affect thermostatic performance. For safety and performance reasons it is recommended that the maximum hot water temperature is limited to 65°C.
- Cold Water Range: up to **25°C**.
- Minimum Recommended Differential between Hot Supply and Outlet Temperature: **12°C**.

Flow Rates

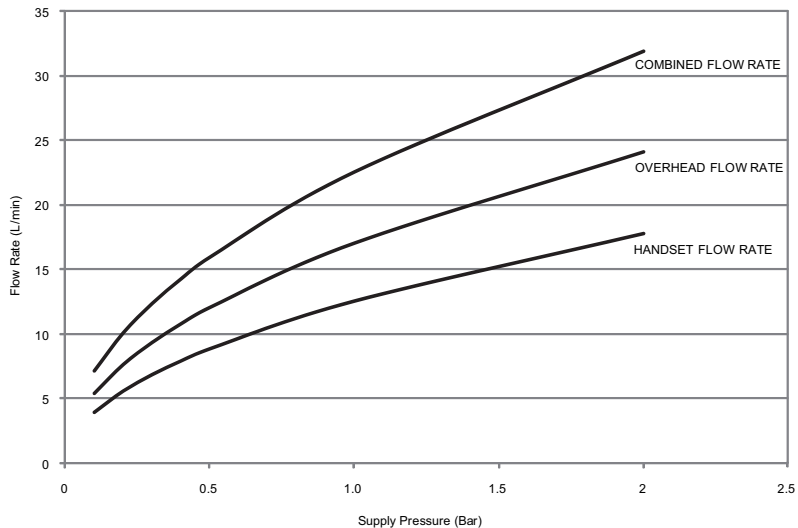

Thermostatic Shut-down

- For safety and comfort the thermostat will shut off the mixing valve **within 2 Seconds** if either supply fails (achieved only if the hot water supply temperature is 12°C above the set blend temperature).

Connections

- Inlets: 15 mm Compression.
- Outlet: ½" BSP Flat Face / 15 mm Compression
- Standard connections are: **hot - left, cold - right, outlet - top**.

Dimensions

Mira Realm

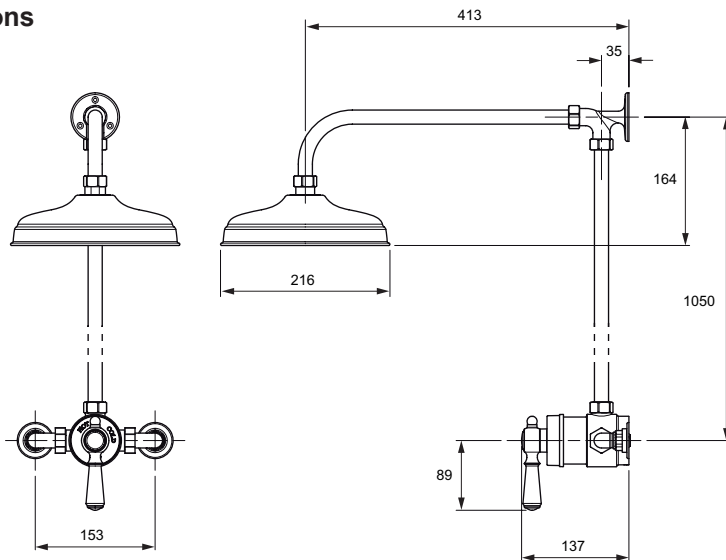

Mira Realm with Diverter

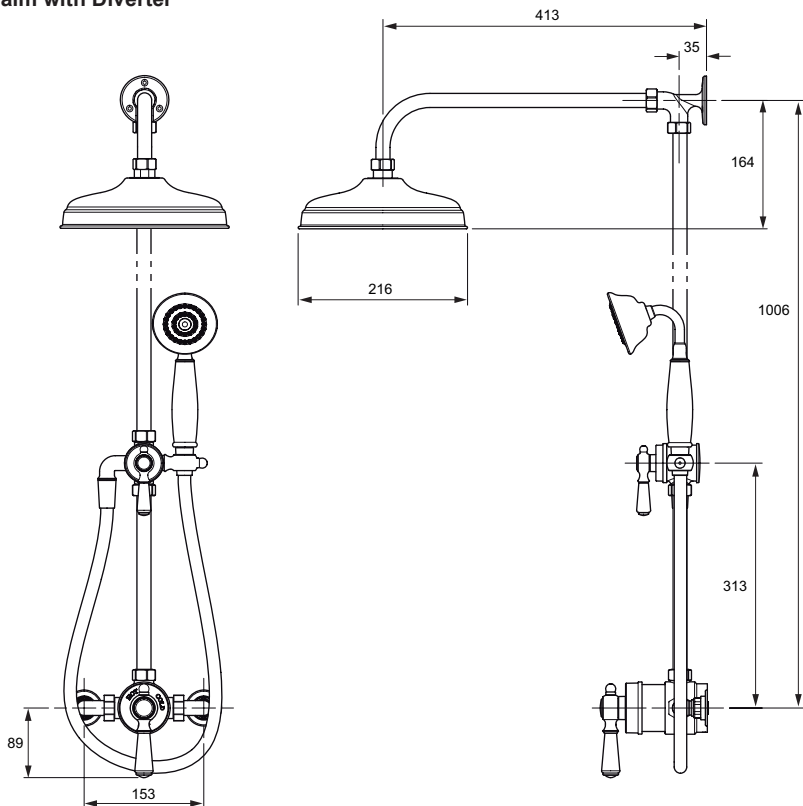

All dimensions in mm

INSTALLATION

Suitable Plumbing Systems

Gravity Fed:

The thermostatic mixer must be fed from a cold water cistern (usually fitted in the loft space) and a hot water cylinder (usually fitted in the airing cupboard) providing nominally equal pressures.

Mains Pressurised Instantaneous Hot Water System (Combination Boiler):

The thermostatic mixer can be installed with systems of this type with balanced pressures. (Recommended Minimum Maintained Pressure: **1.0 Bar**).

There is no flow adjustment with this product. A 12 l/min flow regulator is supplied and is recommended to be fitted in High Pressure systems(see Flow Regulator Installation)

Unvented Mains Pressure System:

The thermostatic mixer can be installed with an unvented, stored hot water system.

There is no flow adjustment with this product. A 12 l/min flow regulator is supplied and is recommended to be fitted in High Pressure systems(see Flow Regulator Installation)

Pumped System:

The thermostatic mixer can be installed with an inlet pump (twin impeller). The pump must be installed in a suitable location and in accordance with its instructions.

General

Installation must be carried out in accordance with these instructions, and must be conducted by designated, qualified and competent personnel.

The installation must comply with the "Water Supply Regulations 1999 (Water Fittings)" or any particular regulations and practices, specified by the local water company or water undertakers.

Note! Make sure that all site requirements correspond to the information given in section: '**Specifications**'.

1. The Mixer must not be installed in an area where it may freeze.
2. For stud partitions alternative fixings may be

required.

3. Isolating valves **must** be installed close to the Mixer for ease of maintenance.
4. Pipework must be rigidly supported and avoid any strain on the connections.
5. Pipework dead-legs should be kept to a minimum.
6. Decide on a suitable position for the Mixer. The position of the Mixer and the Shower Fittings must provide a minimum gap of 25 mm between the spill-over level of the shower tray/bath and the showerhead (refer to illustration). This is to prevent back-siphonage. For further information on the installation of your **Shower Fittings**, refer to the Fittings Installation and User Guide.

Note! Only use Shower Fittings recommended by the manufacturer or supplier.

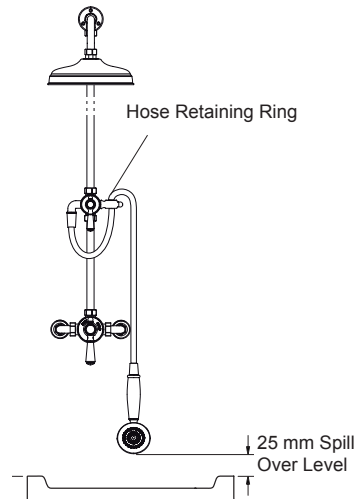

Flow Regulator Installation

Flow regulators are supplied with this product and should be fitted in High Pressure systems to either;

1. Reduce Excessive Force and Flow Rate
2. Reduce Noise through the mixer due to high or unequal pressures
3. Stabilise incoming supply temperatures

Mira Realm

1. The thermostatic mixer can be installed with rear or falling supply inlets. Decide on the most appropriate method for your installation, and if necessary, the inlet elbows can be swivelled to suit.

Note! The Mira Realm with Diverter cannot be installed with a falling supply.

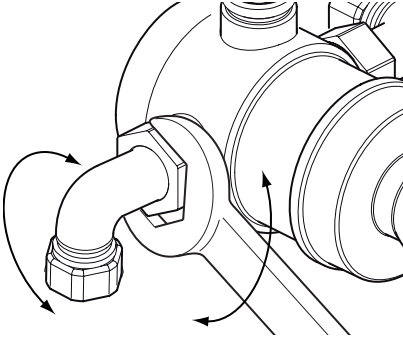

2. Use the installation template to mark the positions of the holes for the backplate and the pipe centres.

For rising or falling supplies the pipe positions should be set 35 mm from the centre of pipe to the finished wall at 153 mm centres.

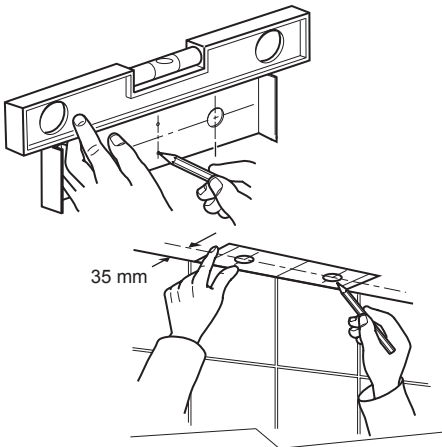

3. For solid walls drill the holes for the backplate with a 6 mm drill and insert the wall plugs.

Note! For other types of wall structure alternative fixings may be required (not supplied).

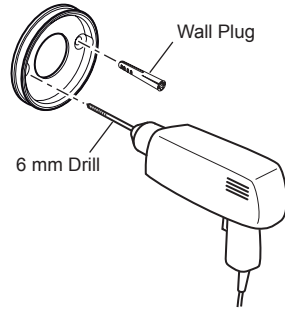

4. For Rear Entry Supplies Only:

- a) Drill the holes for the supply pipes at 153 mm centres.
- b) Recess the inlet holes $\text{Ø} 19 \text{ mm} \times 2 \text{ mm}$ deep to allow for the concealing plates.

5. Fit the supply pipework: **Hot - Left, Cold - Right**. For rear entry supplies the inlet pipework should extend 28 mm from the finished wall surface, for rising or falling supplies the centre of the pipe should be set 35 mm from the finished wall surface.

Note! If it is not possible to install the mixer with this pipework configuration complete the installation then refer to section: '**Reversed Inlet Supplies**'.

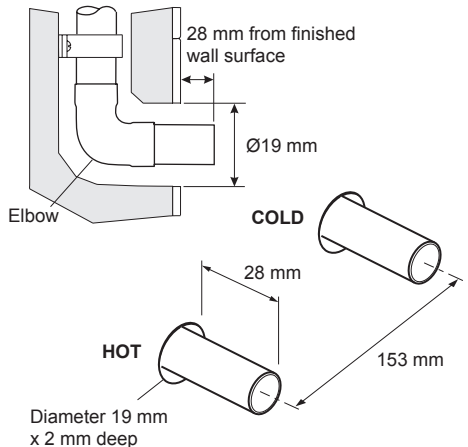

6. Remove the backplate from the mixer by loosening the grub screw with a 2.5 mm hexagonal key.

7. Secure the backplate to the wall using the screws.

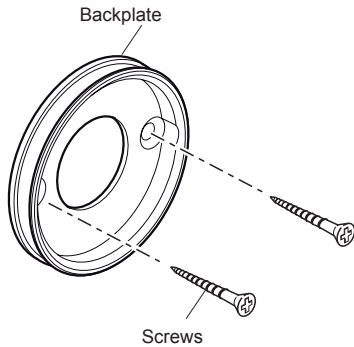

8. For Rear Entry Supplies Only:

- a) Fit the concealing plates over the inlet pipes.

Note! Apply silicone sealant to the back face of the flange.

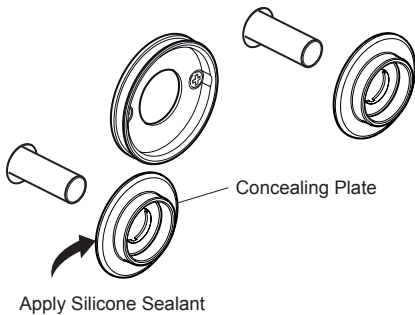

9. **Caution! It is essential at this point that the supply pipework is thoroughly flushed through before connection to the mixer.** Failure to do so may result in product malfunction and will not be covered under the guarantee.

10. Fit the compression nuts and olives onto the pipework.
11. Align the mixer with the pipework and fit onto the backplate.
12. Tighten the compression nuts onto the mixer with a suitable spanner.

Caution! Take care not to damage the chrome surfaces.

13. Tighten the grubscrew to secure the mixer to the backplate.

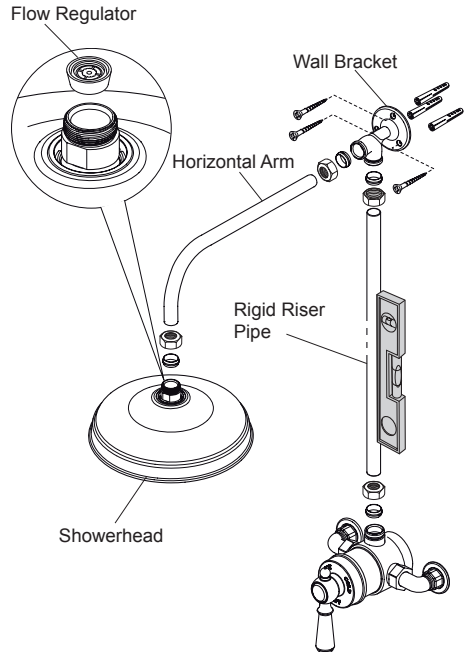

14. Temporarily fit the rigid riser pipe and wall bracket to the shower control outlet and mark the position of the wall bracket. Use a spirit level to ensure the pipe is vertical. Drill the holes and insert the wall plugs.

Note! The vertical rigid riser pipe can be shortened if required. De-burr the pipe ends before making the final connection.

15. Fix the wall bracket, rigid riser pipe, horizontal arm and tighten the three compression fittings on the shower control outlet and horizontal arm.

Note! Care must be taken when tightening compression nuts so that you do not damage the plated surfaces.

16. Turn on the hot and cold water supplies and check for leaks.

17. Thoroughly flush the outlet pipework before connecting the shower head. Slide the compression nut and olive over the horizontal arm and make the connection to the shower head.

Note! If fitting the flow regulator, make sure that it is fitted at this stage.

18. Before using the shower, refer to section: 'Commissioning'.

Mira Realm with Diverter

1. Refer to 'Mira Realm, paragraphs 1 to 13' to install the mixer.

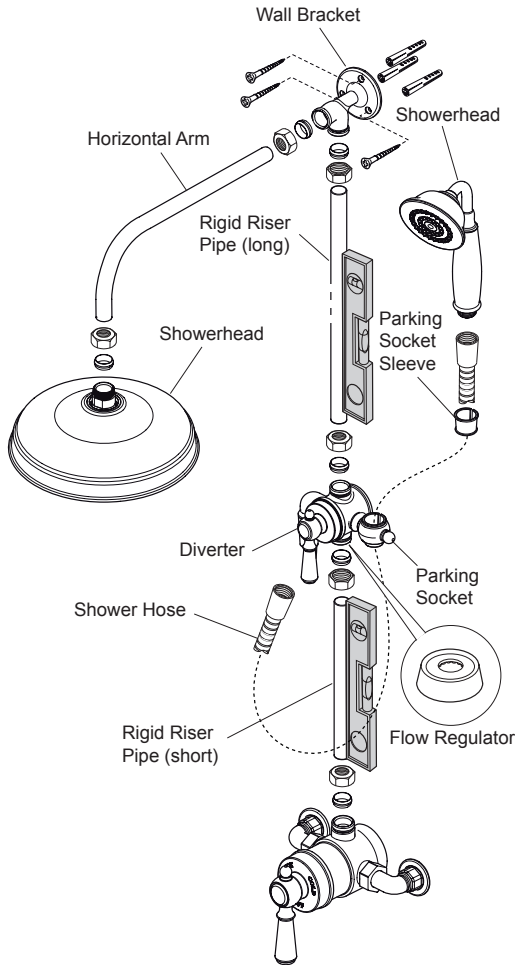

2. Temporarily fit the rigid riser pipe (short), diverter, rigid riser pipe (long) and wall bracket to the shower control outlet and mark the position of the wall bracket. Use a spirit level to ensure the pipes are vertical. Drill the holes and insert the wall plugs.

Note! If fitting the flow regulator, make sure that it is fitted at this stage.

Note! The vertical rigid riser pipes can be shortened if required. De-burr the pipe ends before making the final connection.

Note! The short and long riser pipes can be swapped around if the handset is required at a higher position.

3. Fix the rigid riser pipes, diverter wall bracket and tighten the four compression fittings on the shower control outlet. Fit the horizontal arm and tighten the compression fitting.

Note! Care must be taken when tightening compression nuts so that you do not damage the plated surfaces.

4. Turn on the hot and cold water supplies and check for leaks.
5. Thoroughly flush the outlet pipework before connecting the showerhead. Slide the compression nut and olive over the horizontal arm and make the connection to the shower head.
6. Connect the shower hose to the outlet of the diverter. Make sure that the hose washer is fitted.
7. Pass the hose through the parking socket.
8. Stretch the parking socket sleeve over the hose using the split. Squeeze the parking socket sleeve to fit it into the parking socket. Ensure the split is at the back and the tag is facing the diverter.
9. Connect the showerhead. Make sure that the hose washer is fitted.
10. Locate the showerhead in the parking socket.
11. Before using the shower, refer to section: 'Commissioning'.

REVERSED INLET SUPPLIES

The Mira Realm thermostatic mixer is supplied with inlet connections **Hot - Left, Cold - Right** as standard. If the hot and cold water supply pipes have been reversed during installation the thermostatic cartridge must be removed and rotated 180°.

1. Isolate the hot and cold water supplies and operate the control lever to relieve pressure and drain any residual water.

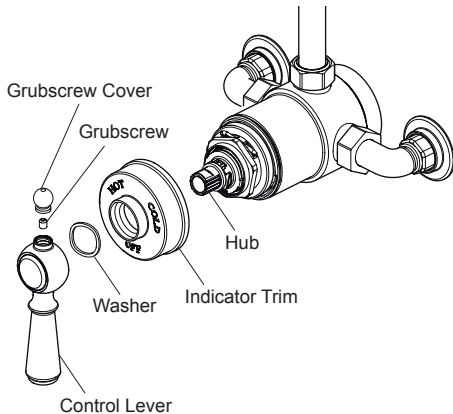

2. Make sure that the control lever is in the 'Off' position. Pointing downwards.
3. Carefully unscrew the grubscrew cover and loosen the grubscrew.
4. Remove the control lever, the washer, the indicator trim and the hub.

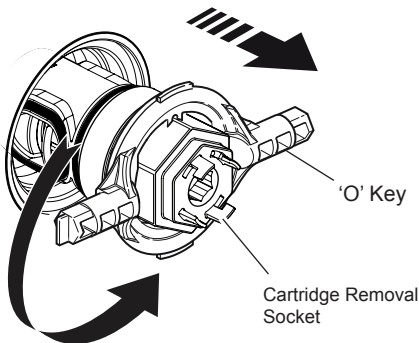

5. Fit the 'O' Key and cartridge removal socket (supplied) onto the cartridge nut and turn anticlockwise. Unscrew fully and pull the cartridge from the mixer body.

6. Rotate the Cartridge 180°.
7. Make sure that the two cartridge inlet seals are fitted and carefully push into the body, aligning the cartridge lugs into the body slots.
Note! Check that the cartridge lug stamped 'H' is aligned with the hot inlet supply.
Important! Take care when fitting the cartridge as damage to the cartridge inlet seals may result in dripping from the shower head.
8. Tighten the nut by turning the 'O' key and the cartridge removal socket clockwise.
9. Refit the hub and the indicator trim in the same orientation that you removed it. Make sure 'OFF' is at the bottom.
10. Fit the washer and the control lever.
11. Tighten the grub screw to secure the control lever.
Note! Make sure that you push the lever in, to compress the washer whilst tightening.
12. Fit the grub screw cover.
13. Before using the Shower, refer to section: 'Commissioning'.

OPERATION

Mira Realm Mixing Valve

The Mira Realm thermostatic mixer is a thermostatic shower control with a single control lever for on/off and temperature control.

The Control Lever operates anti-clockwise in the following sequence:

- Off
- On
- Cold
- Hot
- Maximum Preset Temperature

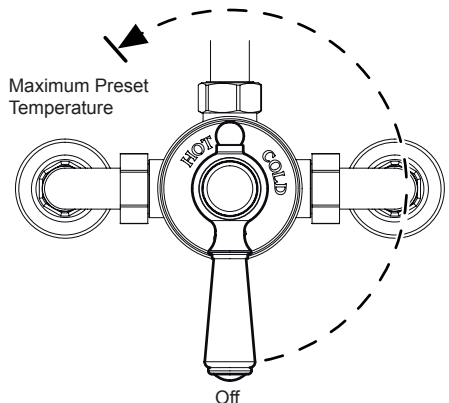

Mira Realm with Diverter

The Mira Realm thermostatic mixer is a thermostatic shower control with a single control lever for on/off and temperature control.

The Control Lever operates anti-clockwise in the following sequence:

- Off
- On
- Cold
- Hot
- Maximum Preset Temperature

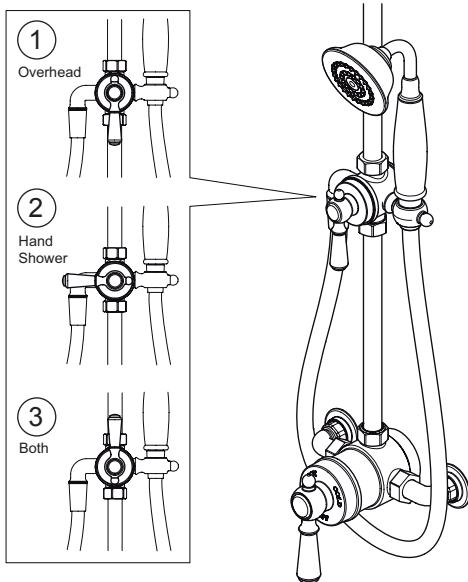

The diverter lever operates as shown above:

- Control Lever Position 1 - Water comes out of the Overhead Shower.
- Control Lever Position 2 - Water comes out of the Handshower.
- Control Lever Position 3 - Water comes out of both the Overhead and the Handshower.

COMMISSIONING

Maximum Temperature Setting

Before using the shower the maximum temperature must be checked to make sure that it is at a safe level. It has been preset to approximately 41°C at the factory but due to variations in site conditions the maximum temperature may need adjustment.

Note! Make sure that the hot water temperature is at least 55°C and that there is sufficient supply.

1. Turn on the shower to the maximum temperature (i.e. fully anticlockwise) and allow the temperature to stabilise.
If the temperature is too hot or too cold, turn off the shower and adjust as follows:
2. Make sure that the control lever is in the 'Off' position. Pointing downwards.
3. Carefully unscrew the grubscrew cover and loosen the grubscrew. Remove the control lever.
4. Turn on the shower to the maximum temperature by rotating the hub fully anticlockwise and allow the temperature to stabilise.
5. Unscrew the hub retaining screw with a 2.5 mm hexagon key.
6. Insert the 2.5 mm hexagon key into the centre of the spindle and engage with the recessed temperature adjusting screw.
7. Rotate the hexagon key until the required maximum temperature is obtained at the shower. Turn anticlockwise to increase the temperature, or clockwise to decrease the temperature ($\frac{1}{4}$ turn = approximately 1°C).
8. Once the desired maximum blend temperature has been achieved turn off the shower.
9. Refit the hub retaining screw.

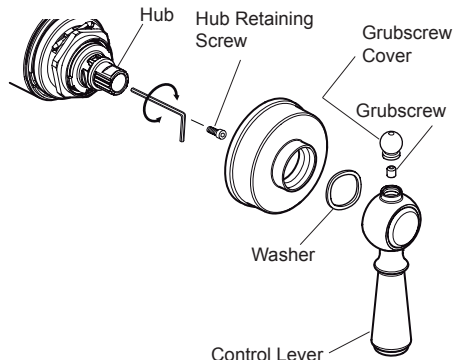

10. Make sure that the hub is positioned fully clockwise.
11. Refit the indicator trim in the same orientation that you removed it. Make sure 'OFF' is at the bottom.
12. Fit the washer and the control lever.
13. Tighten the grub screw to secure the control lever.

Note! Push in the lever when you tighten the grubscrew.
14. Fit the grub screw cover.
15. Check that the showering temperature is correct.

FAULT DIAGNOSIS

If you require a Mira trained service engineer or agent, refer to section: '**Customer Services**'.

Fault Diagnosis

Symptom:

- Only hot or cold water from the mixer outlet.
- Outlet temperature too hot / too cold.

Cause / Rectification:

- Inlets reversed (hot supply to cold supply).
 - No hot water reaching mixer.
 - Check the filters for any blockage.
 - Installation conditions outside operating parameters, refer to sections: '**Specifications**' and '**Commissioning**'.
-

Symptom:

- Fluctuating or reduced flow rate.

Cause / Rectification:

- Check the showerhead, hose and filters for any blockage and clean.
 - Make sure that the maintained inlet pressures are nominally balanced and sufficient, refer to section: '**Specifications**'.
 - Make sure that the inlet temperature differentials are sufficient, refer to section: '**Specifications**'.
 - Flow regulator fitted incorrectly.
 - Air lock or partial blockage in the pipework.
-

Symptom:

- Water leaking from showerhead.

Cause / Rectification:

- Normal for a short period after shut off.
 - Check that the pressures are not in excess of the specifications for the product.
 - Renew the thermostatic cartridge.
-

Symptom:

- Shower noisy.

Cause / Rectification:

- Water pressure high. Rectify water pressure problem / Renew Thermostatic cartridge
- Water pressure unequal. Rectify water pressure problem / Renew Thermostatic cartridge

MAINTENANCE

General

This Product is precision engineered and should give continued safe and controlled performance, provided:

1. It is installed, commissioned, operated and maintained in accordance with manufacturers recommendations.
2. Periodic attention is given, when necessary, to maintain the product in good functional order.

The Mira Realm thermostatic mixer is designed to need only minimal maintenance in normal use. The only serviceable parts are the inlet filters which should be checked and cleaned every 12 months. If a malfunction occurs with the thermostatic cartridge then this will necessitate a complete cartridge replacement.

Note! The cartridge contains no internally serviceable parts.

If you require a Mira trained engineer or agent, refer to section: '**Customer Service**'.

Lubricants

Silicone based lubricants must only be used on the rubber seals.

Caution! Oil based or other lubricant types may cause rapid deterioration of seals.

Cleaning

The chrome plated parts should be cleaned using a mild washing up detergent or soap solution, rinsed and then wiped dry with a soft cloth.

Warning! Many household cleaners contain abrasive and chemical substances, and should not be used for cleaning plated or plastic fittings.

Do not use descalents on this product.

Inlet Filters

The inlet filters should be checked and cleaned as necessary every 12 months.

Note! The inlet filters must not be removed except for cleaning. If the thermostatic mixer is operated without the inlet filters fitted the warranty on the product will be void.

1. Isolate the hot and cold water supplies and operate the control lever to drain any residual water.
2. Unscrew the grub screw securing the shower control to the backplate.

3. Unscrew the inlet and outlet connectors.
4. Remove the shower control.
5. Remove the filters.
6. Clean the filters under a jet of water to remove any lodged particles or replace them.
7. Reassembly is the reversal of the above procedure.
8. Turn on the hot and cold water supplies and check for leaks.

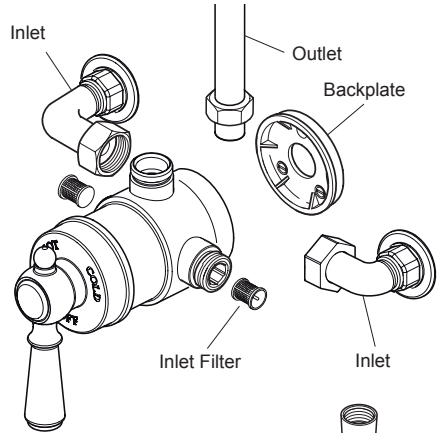

Mira Realm with Diverter

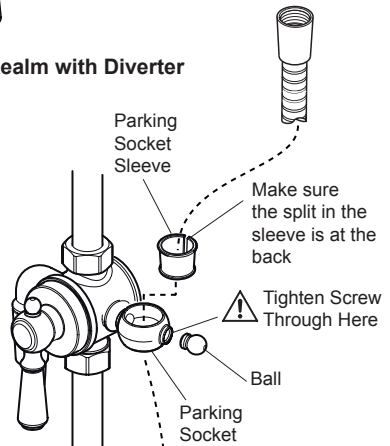

After a period of use the friction device on the parking socket may become loose, this can be tightened as follows:

1. Unscrew the ball.
2. Squeeze the parking socket sleeve together and pull out vertically.
3. Remove the parking socket sleeve from the hose.
4. Remove the hose, back through the parking socket.
5. Tighten the screw.
6. Refit all the components in reverse order.

SPARE PARTS

Mira Realm

1735.114 Valve Seal Pack - Components Identified 'A'

1735.128 Screw Pack - Not Identified

1735.129 Component Pack - Not Identified
(Includes Flow Regulator and Adaptor,
Hose Sleeve and Wall Fixing Screws)

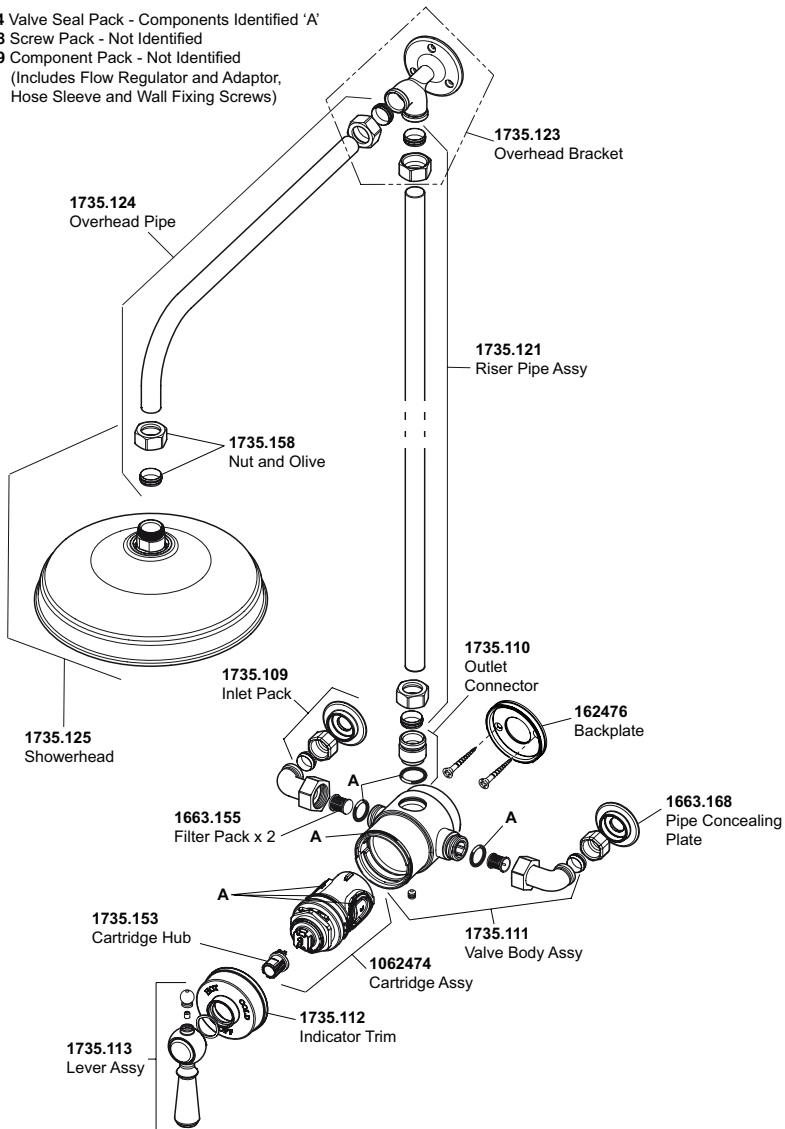

Mira Realm with Diverter

- 1735.114 Valve Seal Pack - Components Identified 'D'
- 1735.115 Diverter Seal Pack - Components Identified 'A'
- 1735.116 Diverter Internals - Components Identified 'B'
- 1735.122 Riser Kit - Components Identified 'C'
- 1735.128 Screw Pack - Not Identified
- 1735.129 Component Pack - Not Identified
(Includes Flow Regulator and Adaptor, Hose Sleeve and Wall Fixing Screws)

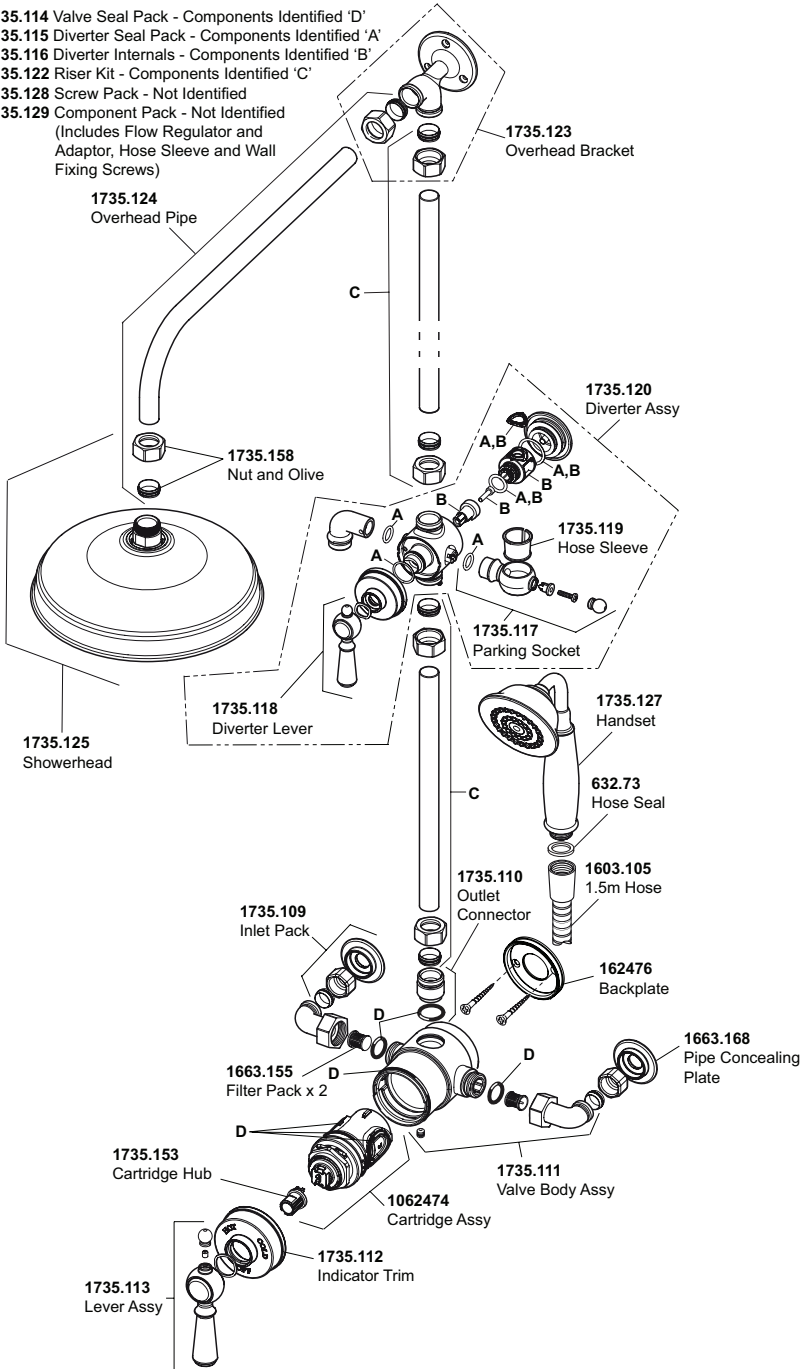

ACCESSORIES

Genuine Mira accessories can be purchased direct from Mira Customer Services (our contact details can be found on the back cover of this guide) or from approved stockists or merchants.



Premium Shower Seat
White/Chrome - 2.1731.001
Grey/Chrome - 2.1731.002

Stylish, slim-line and robust shower seat for use in or outside of the shower area. Folds up when not in use. Maximum User Weight - 150 kg (23.5 stone) **Note!** Must be installed onto a solid wall.

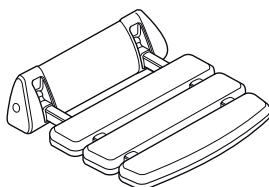

Shower Seat
White - 2.1536.128
White/Chrome - 2.1536.129

For use in or out of the showering area. **Note!** Must be installed onto a solid wall. Shower seat folds up when not in use

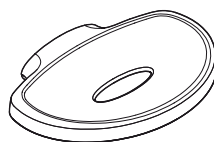

Wall Mounted Soap Dish
White - 1.1540.278
Chrome - 1.1540.279

Wall mounted for use anywhere in, or outside the showering area.



Mira Standard Grab Bars
300 mm - 2.1605.070
450 mm - 2.1605.071
600 mm - 2.1605.072

Premium grade, highly polished, stainless steel grab bars.

Note! Must be installed onto a solid wall.

NOTES

CUSTOMER SERVICE

Guarantee

Your product has the benefit of our manufacturer's guarantee which starts from the date of purchase.

To activate this guarantee, please return your completed registration card, visit our website or free phone 0800 0731248 within 30 days of purchase (UK only).

Within the guarantee period we will resolve defects in materials or workmanship, free of charge, by repairing or replacing parts or product as we may choose.

This guarantee is in addition to your statutory rights and is subject to the following conditions:

- The guarantee applies solely to the original installation under normal use and to the original purchaser only. The product must be installed and maintained in accordance with the instructions given in this user guide.
- Servicing must only be undertaken by us or our appointed representative. **Note!** if a service visit is required the product must be fully installed and connected to services.
- Repair under this guarantee does not extend the original expiry date. The guarantee on any replacement parts or product ends at the original expiry date.
- For shower fittings or consumable items we reserve the right to supply replacement parts only.

The guarantee does not cover:

- Call out charges for non product faults (such as damage or performance issues arising from incorrect installation, improper use, inappropriate cleaning, lack of maintenance, build up of limescale, frost damage, corrosion, system debris or blocked filters) or where no fault has been found with the product.
- Water or electrical supply, waste and isolation issues.
- Compensation for loss of use of the product or consequential loss of any kind.
- Damage or defects caused if the product is repaired or modified by persons not authorised by us or our appointed representative.
- Routine maintenance or replacement parts to comply with the requirements of the TMV 2 or TMV 3 healthcare schemes.
- Accidental or wilful damage.
- Products purchased ex-showroom display.

What to do if something goes wrong

If your product does not work correctly refer to this manual for fault diagnosis and check that it is installed and commissioned in accordance with our instructions. If this does not resolve the issue, contact us for help and advice.

Extended Guarantees

A selection of protection plans are available that enable you to cover repair bills (excludes Eire). Ring 01922 471763 for more details.



Helpdesk Service - Ring our Customer Services Team for product advice, to purchase spare parts or accessories or to set up service visit. You can contact us via phone or e-mail, details below. Please provide your model name, power rating (if applicable) and date of purchase.



Mira Showers Website (www.mirashowers.co.uk)

Visit our website to register your guarantee, download user guides, diagnose faults, purchase our full range of accessories and popular spares, or request a service visit.



Spares and Accessories - We hold the largest stocks of genuine Mira spares and accessories. Contact us for a price or visit our website to purchase items from our accessory range and popular spares.



Service/Repairs - No one knows our products better than our nationwide team of Service Technicians. We can carry out service or repair work to your product both during and after the guarantee period. Ask about our fixed price service repairs.

To Contact Us: UK



0844 571 5000



Fax: 01242 282595



E-mail: Visit www.mirashowers.co.uk/contactus



Mira Customer Services Dept, Cromwell Road, Cheltenham, Gloucestershire, GL52 5EP

To Contact Us: Eire Only



01 531 9337



E-mail: CustomerServiceEire@mirashowers.com

Mira is a registered trade mark of Kohler Mira Limited.

The company reserves the right to alter product specifications without notice.



mira
SHOWERS