

## Leap Walk In

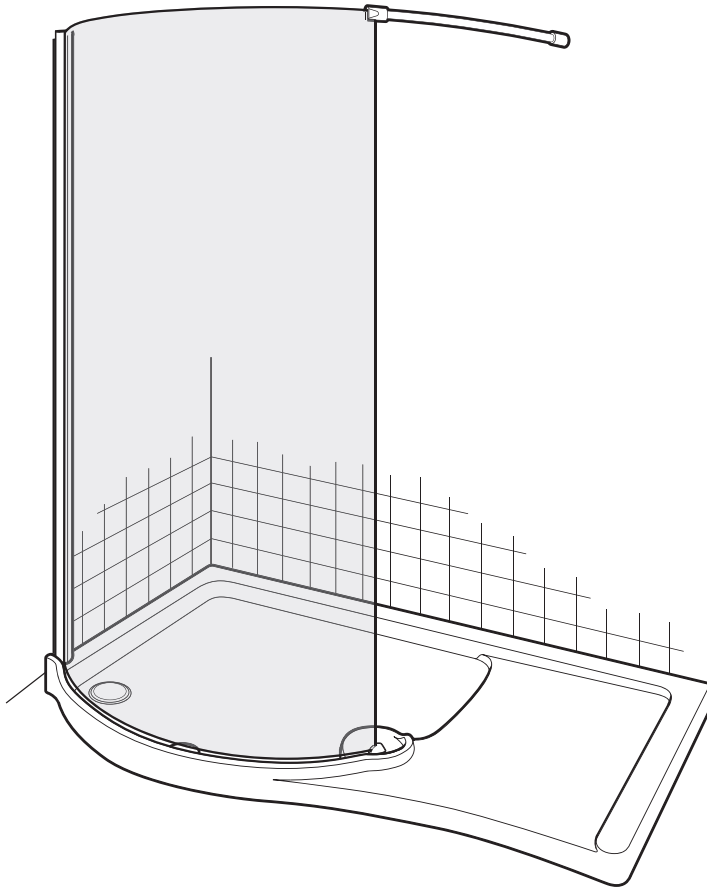

These instructions must be left with the user

Installation Guide

***mira***  
SHOWERS



# INTRODUCTION

Thank you for purchasing a quality Mira product. To enjoy the full potential of your new product, please take time to read this guide thoroughly, having done so, keep it handy for future reference.

The following pages aim to provide comprehensive installation instructions, plus advice on how to care and maintain your product.

We recommend that the unit is installed by a qualified plumber or engineer.

## GENERAL INFORMATION

### General

1. Read all of these instructions and retain this guide for later use.
2. Pass on this guide in the event of change of ownership of the installation site.
3. Follow all warnings, cautions and instructions contained in this guide.
4. Remove all protective tape from the enclosure before installation.
5. Excessive flow rates may lead to overflowing and leaking.
6. Water Spray may extend beyond the entrance of walk-in enclosures and we recommend tiling of the adjacent area.
7. We recommend a drainage test is carried out to ensure the waste is adequate for the flow delivered.
8. Doors that open outwards may drip water onto floor, ensure the floor covering will not be affected by water.
9. Walk ins and divider panels are designed to minimise water escaping outside the enclosure but by their very nature are not fully water tight.

### Safety Information

1. Care should be taken when drilling into walls and floors to avoid any hidden pipes or wires.
2. We strongly recommend that all glass panels are moved by a minimum of two people and that any protective packaging along the glass edges is kept in place for as long as possible to prevent damage before installation.
3. During installation we recommend additional help in lifting heavy doors and side panels.
4. Wear protective footwear when lifting panels.
5. Wear safety glasses when drilling.

### Before Fitting the Enclosure

1. Ensure the tray is level and walls are vertical and square.
2. Shower fittings should be positioned such that water discharges down the centre line of a bath or across the opening of a shower cubicle door.
3. Ensure water is not directed at the shower door or side panels. This could result in water spraying outside of the enclosure.
4. Ensure the door opening is positioned correctly and is adequate for all users.
5. Ensure there is a complete silicone seal between the tray and finished wall.
6. Ensure the door is undamaged and no parts are missing.

7. Ensure the size of door/panel is suitable for the installation. Tempered safety glass cannot be cut.
8. Ensure nothing can impact the door or glass panels during operation.

## When Fitting the Enclosure

1. The wall channels must be installed onto a tiled or waterproof finished flat and even wall surface. Failure to do so will result in an unsatisfactory seal, which may cause property damage.
2. We recommend our enclosures are fitted onto shower trays.  
**Warning!** The use of grout/tile cleaners, scale removers, abrasive scourers, drain unblockers and other powerful detergents may lead to damage of metallic, plated and plastic surfaces, including the tray and shower waste.

## Use of the Enclosure

1. High water pressure and flow may lead to excessive splashing causing water to escape outside of the enclosure.
2. In certain circumstances such as cleaning, water sprayed directly at the seals may escape outside of the enclosure.

# GUARANTEE

For **domestic installations**, your enclosure has the benefit of our lifetime guarantee which starts from date of purchase.

For **non-domestic installations**, we guarantee the product against any defect in materials or workmanship for a period of one year from the date of purchase.

For terms and conditions refer to the back cover of this guide.

# RECOMMENDED USAGE

Domestic	✓
Light Commercial	✓
Heavy Commercial	✗
Healthcare	✗

# TOOLS REQUIRED

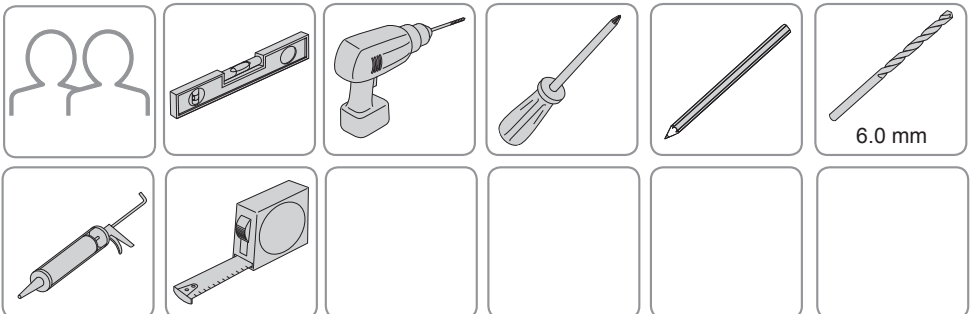

# PACK CONTENTS

Tick the appropriate boxes to familiarise yourself with the part names and to confirm that all of the parts are included.

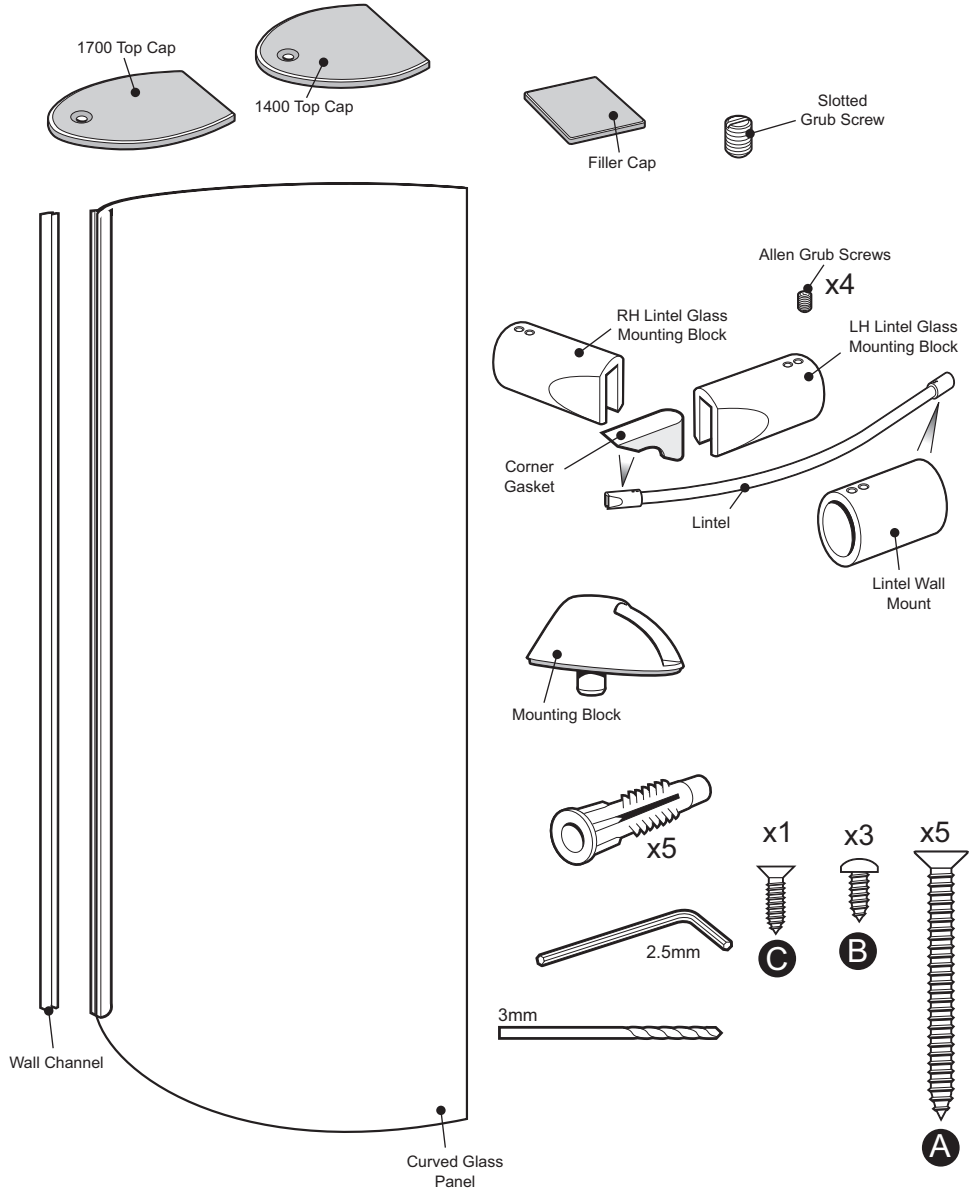

## Documentation

1 x Guarantee Registration Document

# INSTALLATION

The tray should be fitted and the walls tiled before installation of the enclosure.

Mark the position of the wall channel from the wall tiles on the back wall.

745mm (1400 tray)  
640mm (1700 tray)

(adjust the dimension if other than 10mm tile thickness)

Back edge of wall channel

**STEP 1**

Fit the curved panel wall channel to the wall.

Fit the curved panel wall channel to the wall.

Wall channel **MUST** be vertical on the front face.

±0mm

6mm

x3

x3

x3

**STEP 2**

Place the glass mounting block into the tray.

**IMPORTANT**  
Do not remove the adhesive backing from the underside of the mounting block at this stage.

**STEP 3**

Carefully lift the glass into place. The jamb fits onto the wall channel and the bottom corner of the glass fits into the mounting block (see Step 5).

**STEP 4**

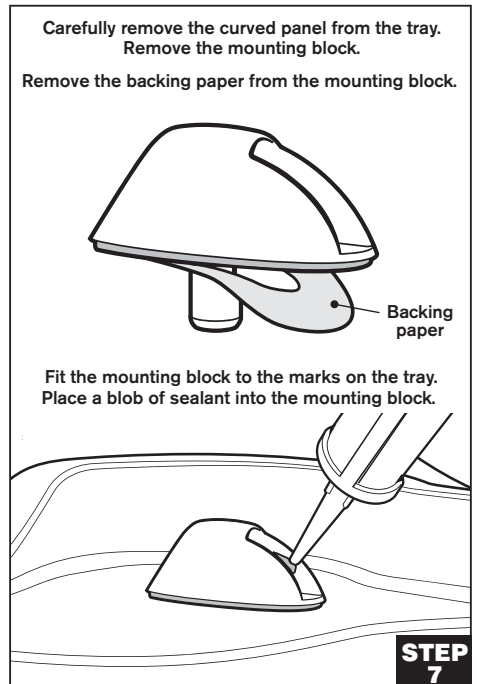
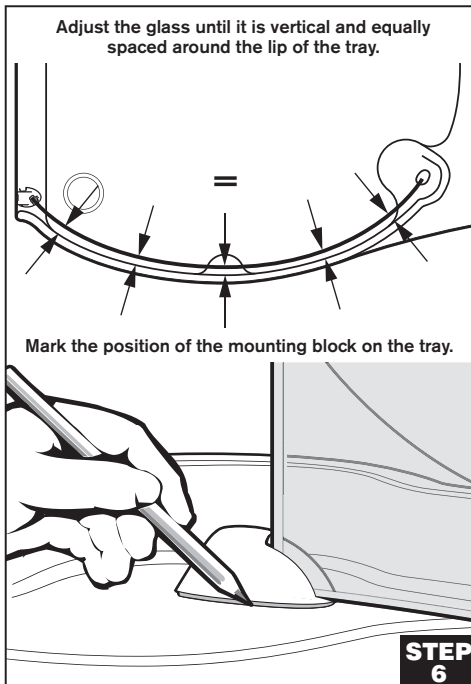
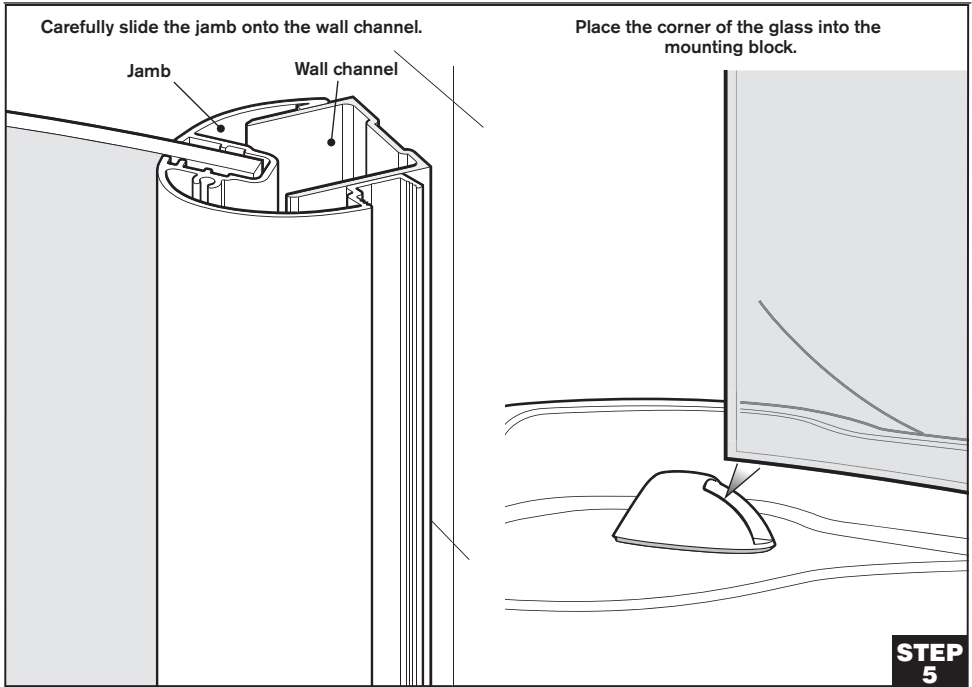

Carefully lift the curved panel back into place and check that the glass is vertical and equally spaced around the lip of the tray.

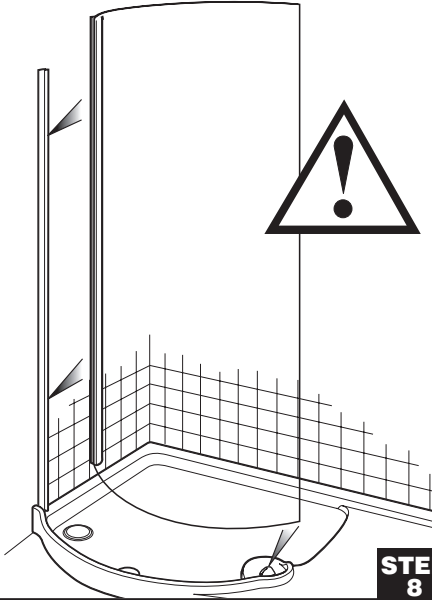

Drill 3 x 3mm holes through the jamb into the wall channel.

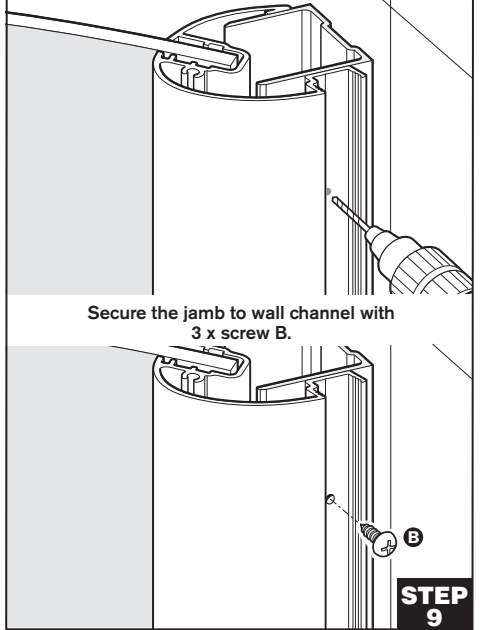

Secure the jamb to wall channel with 3 x screw B.

Mark the fixing point for the lintel on the wall at the height of the top of the glass.

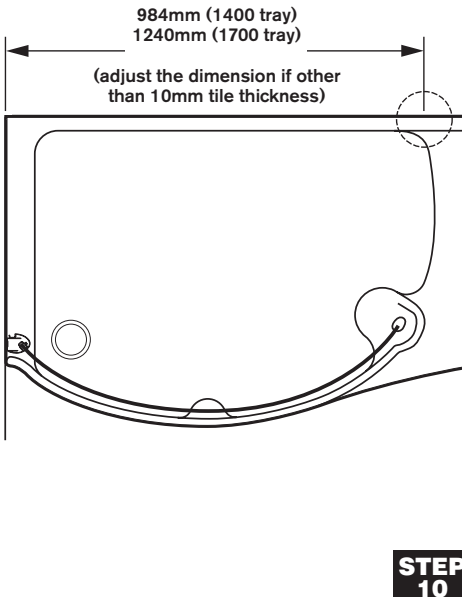

984mm (1400 tray)  
1240mm (1700 tray)

(adjust the dimension if other than 10mm tile thickness)

Loosely fit the parts of the lintel together.

Note: the lintel end with a straight section goes towards the wall.

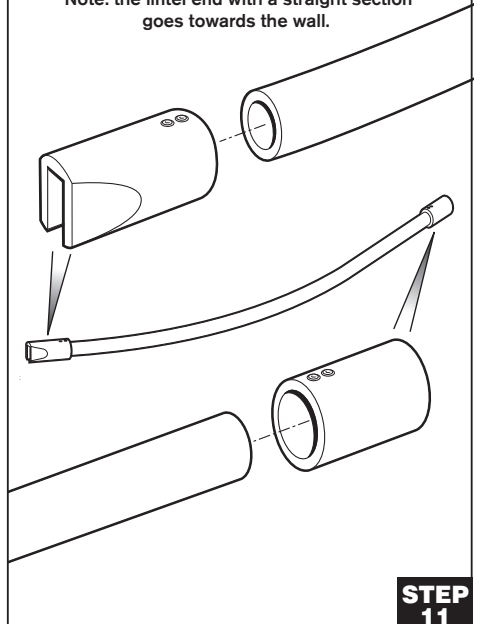



Place the lintel on top of the glass.

Ensure the glass is vertical and the lintel is horizontal.

Fit the corner glass gasket to the glass then place the lintel glass mounting block on top.

When the lintel is horizontal and the inner edge of the wall mount is against the mark, draw around the wall mount.

**STEP 12**

Remove the lintel. Take the wall mount off the lintel and place on the wall as marked.

Mark the position of the two fixing holes on the wall

Drill 2 x 6mm holes.

Fit plugs.

Secure the wall mount with 2 x screw A.

**STEP 13**

Fit the lintel to the wall mount.

Fit the mounting block to the glass and lock in place by turning screw 'A'.

**STEP 14**

Ensure the glass is vertical and the lintel is horizontal.

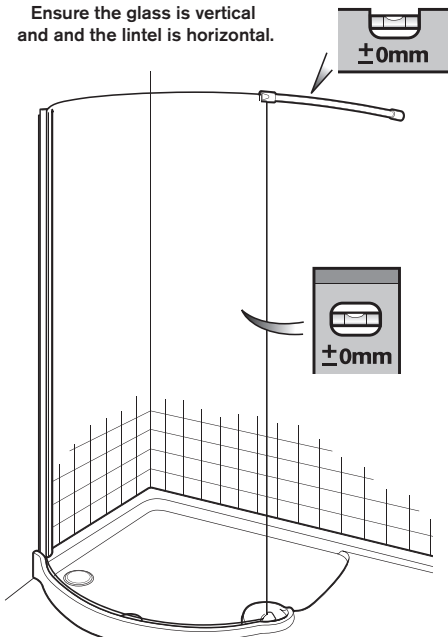

±0mm

±0mm

If any adjustment is required, move the lintel in or out until the glass is vertical.

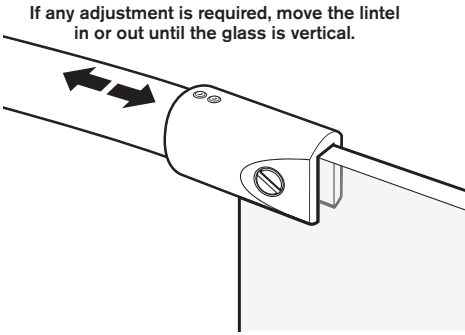

When the glass and lintel are in the correct position tighten the grub screws at both ends.

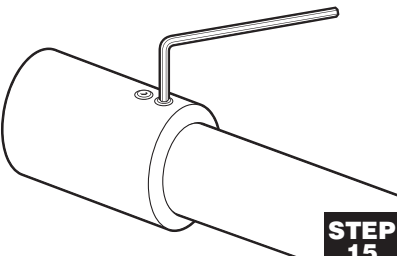

**STEP 15**

Fit the cover strip.

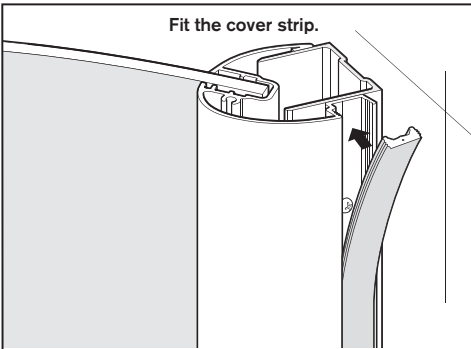

Fit the top caps.

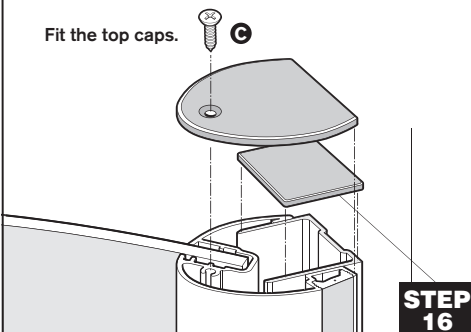

**STEP 16**

Seal between the wall channel and the wall.

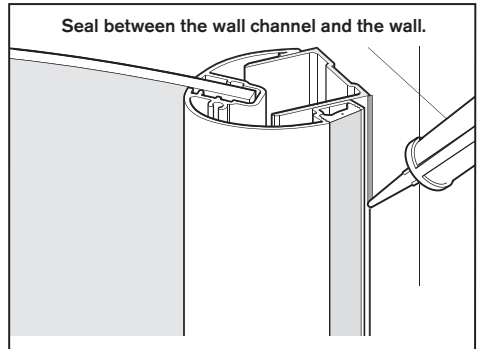

Do not use the enclosure for at least 24 hours.



**STEP 17**

# MAINTENANCE

## General Maintenance

Providing the shower enclosure has been correctly installed and is operated in accordance with the instructions contained in this guide, difficulties should not arise. If any maintenance is required then it must be carried out by a competent tradesperson to whom the maintenance instructions are provided.

Before replacing any parts ensure the underlying cause of the malfunction has been resolved.

## Cleaning

**Warning!** The use of grout/tile cleaners, scale removers, abrasive scourers, drain unblockers and other powerful detergents may lead to damage of metallic, plated and plastic surfaces, including the tray and shower waste.

Avoid the use of 'spray and leave' cleaners. Any cleaner used should have a pH level between 4 and 8 and immediately wiped dry using a soft cloth.

## Care

To preserve the beauty of your shower enclosure for many years, please observe the following care instructions:

Rinse glass and frame with clear water after showering. Remove water droplets with a squeegee. **Do not rub dry!** To clean your shower hygienically and easily, we recommend the use of a biodegradable cleanser.

Regular cleansing with a biodegradable cleanser prevents stubborn stains and ensures a clean and hygienic surface for many years. Do not use scouring or caustic cleansers under any circumstances! These can damage the surface of the frame, glass and decorative parts as well as the plastic parts.

## Chrome Parts

Use only cleansers expressly specified for chrome!

## KOHLER Glass Cleaner

For occasional cleaning of glass treated with KOHLER Glass Protector or for more regular maintenance of untreated surfaces, we recommend using KOHLER Glass Cleaner.

The cleaner cleans and polishes without smearing or streaking and rejuvenates the Glass Protector.

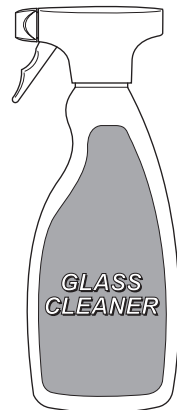

# SPARE PARTS

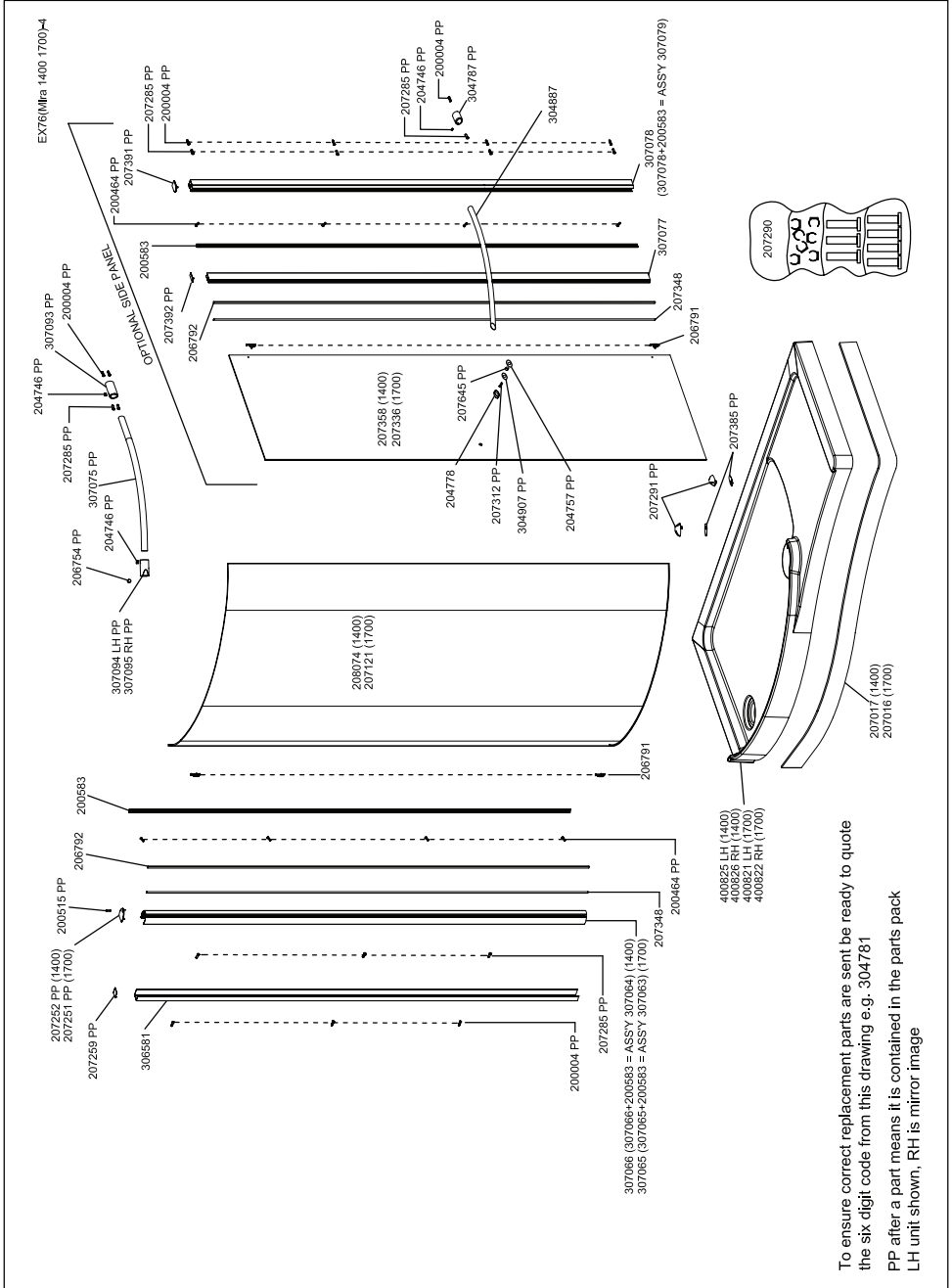

To ensure correct replacement parts are sent be ready to quote the six digit code from this drawing e.g. 304781  
 PP after a part means it is contained in the parts pack  
 LH unit shown, RH is mirror image

# NOTES

# NOTES

# DECLARATION OF PERFORMANCE

## DECLARATION OF PERFORMANCE

**Brand name:** Mira

**Product name:** Leap Shower Enclosures

**Product Range:** Leap Pivot Door, Leap Sliding Door, Leap Quadrant Enclosure, Leap Walk in Enclosure, Leap Extended Sliding Door  
Leap Bi-Fold Door, Leap Side Panel, Leap Pentagon Enclosure, Leap Double Door Slider

**Product type:** Domestic Shower Enclosure

**Manufacturer:** Kohler Mira Ltd  
Cromwell Road, Cheltenham  
Gloucestershire GL52 5EP  
United Kingdom.

**Directives:** EU 305/2011 Construction Products Regulations

**System of assessment:** System 4:  
Type testing / Factory production Control

**Standards:** EN 14428:2004 +A1:2008.  
Shower enclosures – Functional requirements and test methods.

Essential Characteristics	Performance	Harmonised technical specification
IR-CA-DA	Compliant	EN 14428:2004 +A1:2008

The performance of the products described above, are in conformity with the relevant community harmonisation legislation.

This declaration of performance is issued under the sole responsibility of Kohler Mira Ltd.

Signed for and on behalf of Kohler Mira Ltd.

**Signature:** 

**Name:** Andrew Baines  
**Place:** Cheltenham, UK  
**Doc. No.:** CE 0099

**Position:** NPD Director  
**Date:** 1<sup>st</sup> September 2014  
**Issue:** 1.



# CUSTOMER SERVICE

## Guarantee

Your enclosure has the benefit of our lifetime guarantee which starts from the date of purchase. This guarantee only applies in the United Kingdom and the Republic of Ireland.

To activate this guarantee, you must return your completed registration card with a copy of proof of purchase from an approved Mira retailer within 30 days of purchase.

**This guarantee is in addition to your statutory rights and is subject to conditions (see registration card).**

## What to do if something goes wrong

If your product does not function correctly when you first use it, contact your installer to check that it is installed in accordance with the instructions in this manual.

If this does not resolve the issue, contact our Customer Services Team who will offer you or your installer help and advice.



### Helpdesk Service

Our Customer Services Team is comprehensively trained and can offer help and advice, spare parts, accessories or a service visit.

We will need you to have your model name, model number and date of purchase.



### Mira Showers Website ([www.mirashowers.co.uk](http://www.mirashowers.co.uk))

From our website you can register your guarantee, download additional user guides, diagnose faults, purchase our full range of accessories and popular spares, refer to our FAQ's and request a service visit.



### Spares and Accessories

We hold the largest stocks of genuine Mira spares and accessories.

Contact us for a price and to purchase spares or accessories (Only available in the United Kingdom).



### Service / Repairs

No one knows our products better than our nationwide team of Service Technicians. We can carry out service or repair work to your product both during and after the guarantee period (Only available in the United Kingdom and the Republic of Ireland).

Ask about our fixed price service repairs.

## To Contact Us: UK



0844 571 5000



Fax: 01242 282595



E-mail: [www.mirashowers.co.uk/contactus](mailto:www.mirashowers.co.uk/contactus)



Kohler Mira Ltd, Cromwell Road, Cheltenham, Gloucestershire  
GL52 5EP, UK.

#### Mira

Leap Range of Domestic Shower Enclosures.

Declaration of Performance: CE 0099

Pivot Door, Bi-Fold Door, Sliding Door, Side Panel, Quadrant Enclosure, Pentagon Enclosure, Walk in Enclosure, Double Door Slider, Extended Sliding Door.

Essential Characteristics	Performance	Specification
IR-CA-DA	Compliant	EN 14428:2004 +A1:2008

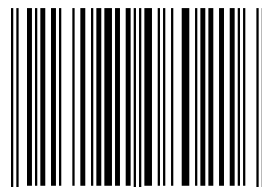

5 013181 080216 >

Mira is a registered trade mark of Kohler Mira Limited.

The company reserves the right to alter product specifications without notice.

**mira**  
SHOWERS