

# ***mira***

**SHOWERS**

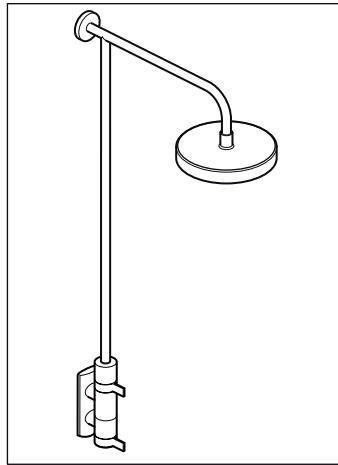
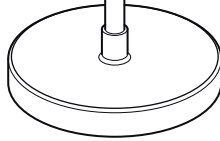
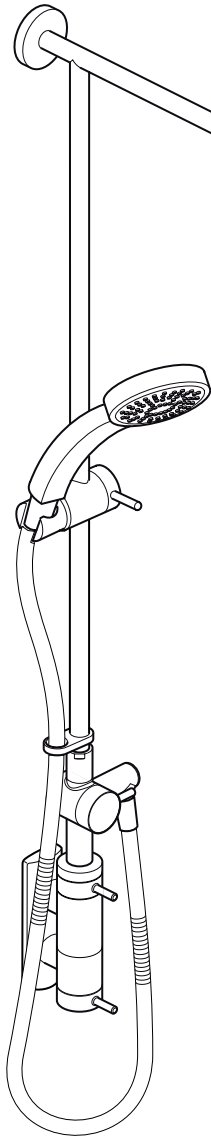

MIRA STYLUS & MIRA MINILUXE

THERMOSTATIC MIXERS

INSTALLATION & USER GUIDE

**These instructions must be left with the user.**

## CONTENTS

<b>Introduction</b>	<b>2</b>
Guarantee	2
Recommended Usage	3
Patents and Design Registration	3
<b>Safety Warnings</b>	<b>4</b>
<b>Pack Contents</b>	<b>5</b>
<b>Specifications</b>	<b>6</b>
Pressures	6
Temperatures	6
Thermostatic Shut-down	6
Connections	6
Dimensions	6
<b>Installation</b>	<b>7</b>
Suitable Plumbing Systems	7
General	7
Flow Regulator	7
Installing the Thermostatic Mixer	8
<b>Commissioning</b>	<b>12</b>
Maximum Temperature Setting	12
<b>Operation</b>	<b>12</b>
Operating the Divertor	12
Flow Control	12
Temperature Control	12
<b>User Maintenance</b>	<b>13</b>
Fault Diagnosis	13
Lubricants	13
Cleaning	13
<b>Spare Parts</b>	<b>14</b>
<b>Customer Service</b>	<b>Back Page</b>

## INTRODUCTION

Thank you for purchasing a quality Mira product. To enjoy the full potential of your new product, please take time to read this guide thoroughly, having done so, keep it handy for future reference.

The Mira Stylus and Mira Miniluxe are thermostatic mixers which have separate flow and temperature controls.

The Mira Miniluxe **ER** is an exposed valve supplied with a rigid riser to a deluge head.

The Mira Stylus **ERD** and Mira Miniluxe **ERD** are exposed valves supplied with a rigid riser to a deluge head and a divertor assembly, single mode showerhead and shower fittings kit.

The thermostatic mixer incorporates a wax capsule temperature sensing unit, which provides an almost immediate response to changes in pressures or temperature of the incoming water supplies to maintain the selected temperature. An adjustable maximum temperature stop is provided which limits the temperature to a safe level. Inlet filters are fitted to protect the thermostatic cartridge.

### Guarantee

For **domestic installations**, Mira Showers guarantee the Mira Stylus and Mira Miniluxe against any defect in materials or workmanship for a period of **three** years from the date of purchase (shower fittings for one year).

For terms and conditions refer to the back cover of this guide.

If you experience any difficulty with the installation or operation of your new thermostatic mixer, please refer to '**Fault Diagnosis**', before contacting Mira Showers. Our contact details can be found on the back cover of this guide.

## Recommended Usage

Application	Valve with Fittings
Domestic	✓
Light Commercial	✘
Heavy Commercial	✘
Healthcare	✘

## Patents and Design Registration

### Patents:

GB: 2 340 210, 2 392 223, 2 392 224

Euro: 1 672 257 FR, GB, IT, NL, SE

Germany: 60 2005 002 339.9

### Patent Applications

US: 2006-0124758-A1

### Design Registration:

000793401-00013-00014-00015

## SAFETY WARNINGS

Mira thermostatic mixers are precision engineered and should give continued safe and controlled performance, provided:

1. They are installed, commissioned, operated and maintained in accordance with manufacturer's recommendations.
2. Periodic attention is given, when necessary, to maintain the product in good functional order.

### Caution!

1. Read all of these instructions.
2. Retain this guide for later use.
3. Pass on this guide in the event of change of ownership of the installation site.
4. Follow all warnings, cautions and instructions contained in this guide.
5. Anyone who may have difficulty understanding or operating the controls of any shower should be attended whilst showering. Particular consideration should be given to the young, the elderly, the infirm or anyone inexperienced in the correct operation of the controls.
6. Rapid/Excessive movement of the flow and/or temperature control levers may result in momentary unstable blend temperatures.
7. Care is required when adjusting flow, diverting to different outlets or adjusting temperature. Make sure that the temperature has stabilised.
8. Do not remove or tighten the body grubscrews.

9. Care must be taken when positioning the thermostatic mixer. Make sure that there is sufficient headroom and ceiling clearance to install the rigid riser rail and overhead pipe.  
**Caution! Do not** cut the rigid riser rail.
10. When this product has reached the end of its serviceable life, it should be disposed of in a safe manner, in accordance with current local authority recycling, or waste disposal policy.

**Caution! Do not** remove or tighten these grubscrews.

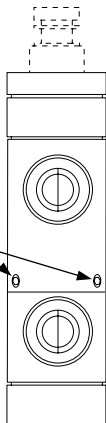

# PACK CONTENTS

Tick the appropriate boxes to familiarise yourself with the part names and to confirm that all of the parts are included.

- 2 x Wall Plugs
- 2 x Fixing Screws
- 1 x Securing Bracket
- 1 x Securing Bracket Cover
- 1 x Pin

- 1 x Rigid Riser Rail (supplied in 2 parts on some models)

- 1 x Rigid Riser Overhead Pipe

- 1 x M4 x 12 mm Grubscrew
- 2 x Olives
- 4 x Wall Plugs
- 4 x Fixing Screws
- 1 x 2 mm Hexagonal Key

- 1 x Deluge Head & Seal

**OR**

- 1 x Deluge Head & Seal
- 1 x Divertor Assembly (inc Nut, Olive & M4 x 6 mm Grubscrew)
- 1 x EV Fittings Kit
- 1 x 2 mm Hexagonal Key

Divertor Models Only

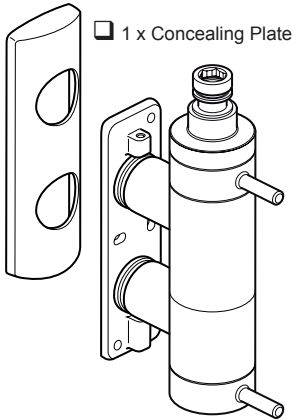

- 1 x Concealing Plate

**Mira Stylus ERD**

- 1 x Thermostatic Mixer (supplied fitted to the backplate)

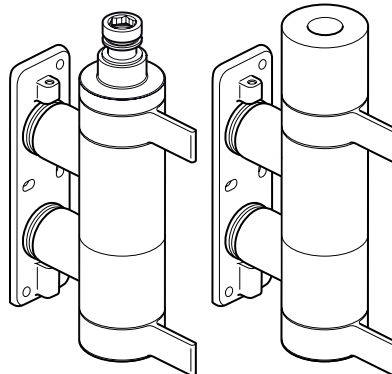

**Mira Miniluxe ERD**

**Mira Miniluxe ER**

## Documentation

- 1 x Guarantee Registration Document

# SPECIFICATIONS

## Pressures

- Max Static Pressure: **10 Bar**.
- Max Maintained Pressure: **5 Bar**.
- Min Maintained Pressure (Gravity System): **0.1 Bar**. (0.1 bar = 1 Metre head from cold tank base to showerhead outlet).

**Note!** For gravity fed / other low pressure systems (0.5 bar or below) remove the outlet flow regulator. Refer to section: '**Installation, Flow Regulator**'.

- For optimum performance supplies should be nominally equal.

## Temperatures

- Factory Pre-set (Blend) Shower: **43°C**.
- Optimum Thermostatic Control Range: **35°C to 43°C** (achieved with supplies of 15°C cold, 65°C hot and nominally equal pressures).
- Recommended Hot Supply: **60°C to 65°C**  
**Note!** The mixing valve can operate at higher temperatures for short periods without damage, however this could detrimentally affect thermostatic performance. For safety and performance reasons it is recommended that the maximum hot water temperature is limited to 65°C.
- Cold Water Range: up to **25°C**.
- Minimum Recommended Differential between Hot Supply and Outlet Temperature: **12°C**.

## Thermostatic Shut-down

- For safety and comfort the thermostat will shut off the mixing valve **within 2 Seconds** if either supply fails (achieved only if the blend temperature has a minimum differential of 12°C from either supply temperature).

## Connections

The thermostatic mixer can only be installed with rear supply inlets and the supply pipework must be connected as follows:

- Hot: Top (side nearest flow control), 15 mm compression.
- Cold: Bottom (side nearest temperature control), 15 mm compression.
- Outlet: 15 mm compression to rigid riser.

**Note!** This product does not allow for reversed inlets and will deliver unstable temperatures if fitted incorrectly.

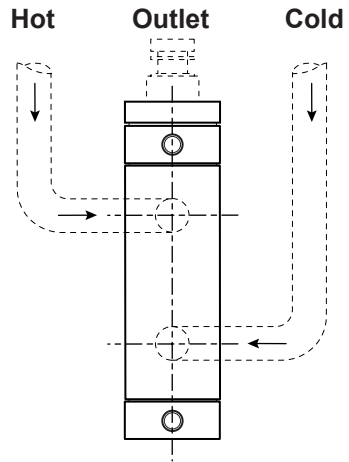

## Dimensions

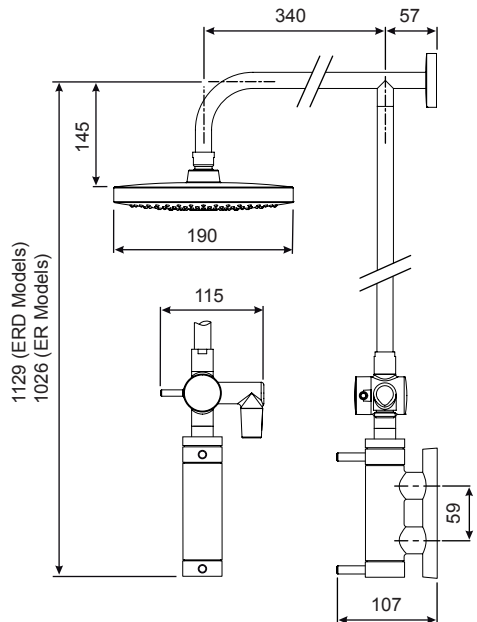

All dimensions in mm

# INSTALLATION

## Suitable Plumbing Systems

### Gravity Fed:

The thermostatic mixer must be fed from a cold water cistern (usually fitted in the loft space) and a hot water cylinder (usually fitted in the airing cupboard) providing nominally equal pressures.

### Mains Pressurised Instantaneous Hot Water System (Combination Boiler):

The thermostatic mixer can be installed with systems of this type with balanced pressures. (Recommended Minimum Maintained Pressure: **1.0 Bar**).

### Unvented Mains Pressure System:

The thermostatic mixer can be installed with an unvented, stored hot water system.

### Pumped System:

The thermostatic mixer can be installed with an inlet pump (twin impeller). The pump must be installed in a suitable location and in accordance with its instructions.

## General

Installation must be carried out in accordance with these instructions, and must be conducted by designated, qualified and competent personnel.

The installation must comply with the "Water Supply Regulations 1999 (Water Fittings)" or any particular regulations and practices, specified by the local water company or water undertakers.

**Note!** Make sure that all site requirements correspond to the information given in section: '**Specifications**'.

1. The Mixer must not be installed in an area where it may freeze.
2. For stud partitions alternative fixings may be required.
3. Isolating valves must be installed close to the Mixer for ease of maintenance.
4. Pipework must be rigidly supported and avoid any strain on the connections.
5. Pipework dead-legs should be kept to a minimum.

6. Decide on a suitable position for the Mixer, make sure that there is sufficient headroom and ceiling clearance to install the rigid riser rail and overhead pipe.

**Caution! Do not** cut the rigid riser rail.

For **ERD** models the position of the Mixer and the Shower Fittings must provide a minimum gap of 25 mm between the spill-over level of the shower tray/bath and the showerhead (refer to illustration). This is to prevent back-siphonage.

**Note!** Only use Shower Fittings recommended by the manufacturer or supplier.

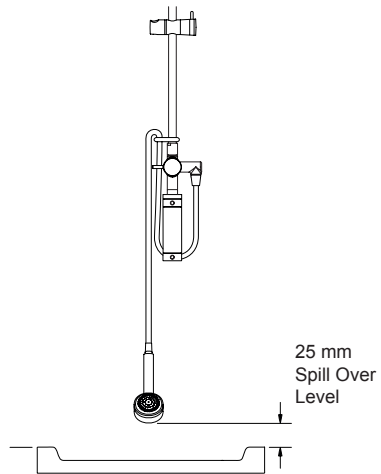

## Flow Regulator

Site conditions will determine the flow regulator requirements.

For gravity fed / other low pressure systems (0.5 bar or below) remove the outlet flow regulator.

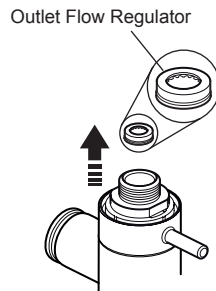

## Installing the Thermostatic Mixer

1. The thermostatic mixer must be fitted vertically as illustrated and can only be installed with rear supply inlets. The supply pipework **must** be connected as follows:

- Hot to Top Inlet
- Cold to Bottom Inlet
- Top Outlet.

**Important!** This product does not allow for reversed inlets.

2. Determine the route for the hot and cold supply pipework.

**Important!** Make sure that there is sufficient headroom and ceiling clearance to install the rigid riser rail and overhead pipe.

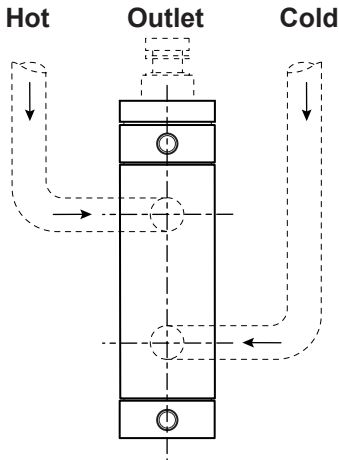

4. Loosen the 2 backplate grub screws with the 2 mm hexagonal key (supplied) and pull the mixer and concealing plate from the backplate.

5. Unscrew the inlet nuts from the backplate.

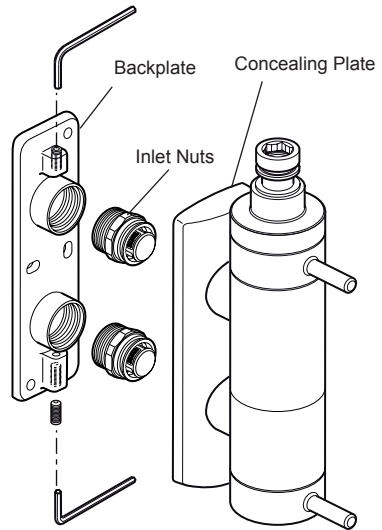

6. Using the backplate as a guide, mark the positions of the fixing holes and the pipe centres.

**Important!** Make sure that there is sufficient headroom and ceiling clearance to install the rigid riser rail and overhead pipe.

**Note!** Make sure that the backplate is the correct way up (refer to illustration).

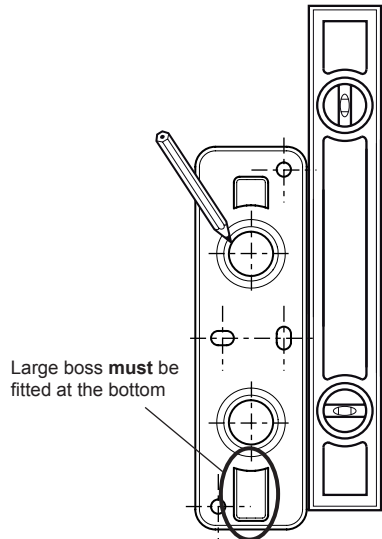



7. For solid walls drill the fixing holes for the backplate with a 6 mm drill and insert the wall plugs (supplied). For other types of wall structure alternative fixings may be required (not supplied).

8. Drill the holes for the supply pipes and fit the supply pipework:

Hot to Top Inlet, Cold to Bottom Inlet

**Note!** The inlet pipework should extend between 12 and 18 mm from the finished wall surface.

**Caution!** Make sure that the pipework is not damaged otherwise the olives will not seal.

9. Fit the backplate over the inlet pipes and secure to the wall using the fixing screws (supplied).

10. **Caution!** It is essential at this point that the supply pipework is thoroughly flushed through before connection to the mixer. Failure to do so may result in product malfunction and will not be covered under the guarantee.

11. Fit the olives onto the inlet pipework and tighten the inlet nuts using a suitable spanner.

**Caution!** Do not overtighten.

**Important!** Make sure that the inlet filters are fitted in the inlet nuts as illustrated.

12. Make sure that the concealing plate (with the hole at the bottom) is loosely fitted over the mixing valve inlets and align the mixer with the inlet nuts. Push on fully and tighten the grubscrews to secure the mixer to the backplate. Make sure that the grubscrews are engaged fully in the valve body grooves.

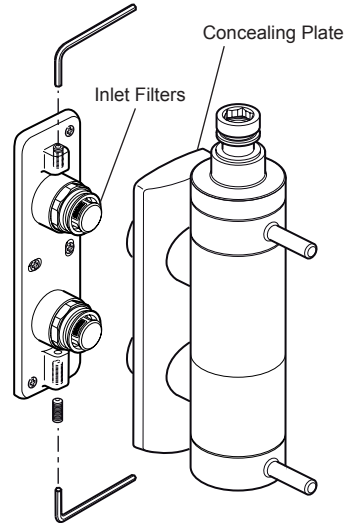

13. Push the concealing plate onto the backplate, secure with the M4 x 12 mm grubscrew.

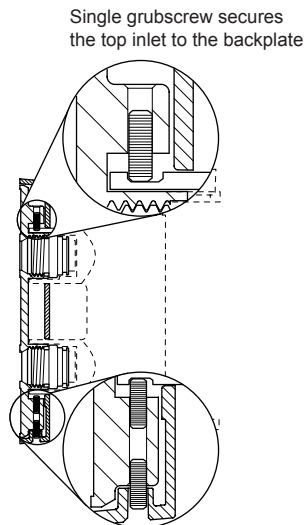
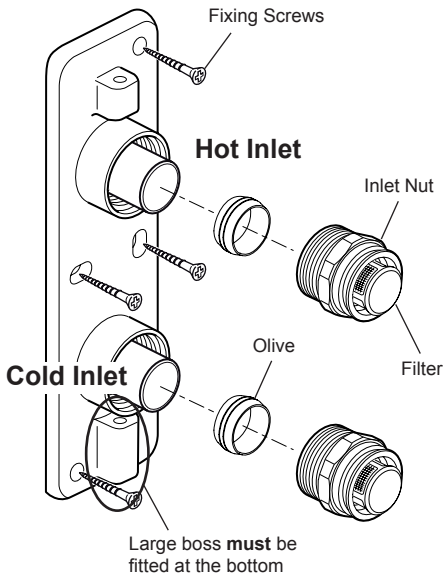

Two grubscrews secure both the bottom inlet and the concealing plate to the backplate

- 14.Important!** A 12 litre/minute flow regulator is fitted inside the outlet. This can be removed for gravity fed / other low pressure systems (0.5 bar or below).

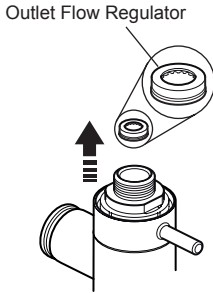

- 15.**For ERD models fit the divertor onto the mixer outlet and tighten the M4 x 6 mm grub screw with a 2 mm hexagonal key (supplied). The divertor must be fitted as illustrated, with the divertor knob at the front and the outlet to the right of the mixing valve.

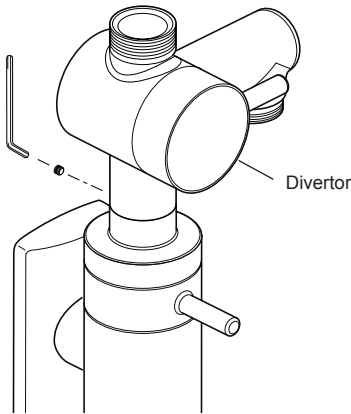

- 16.**Screw the rigid riser rail into the rigid riser overhead pipe.

**Note!** If your rigid riser rail is supplied in two parts, first screw them together.

- 17.**Locate the rigid riser rail into the divertor / mixing valve outlet and the rigid riser overhead pipe into the securing bracket, make sure that they are pushed fully home.

**Important!** Align the rigid riser overhead pipe with the securing bracket using the pin. Use a spirit level to make sure that the rigid riser rail is vertical and mark the position of the fixing holes for the securing bracket on the wall.

**Caution! Do not** cut the rigid riser rail.

- 18.**For solid walls drill the fixing holes for the securing bracket with a 6 mm drill and insert the wall plugs (supplied). For other types of wall structure alternative fixings may be required (not supplied).

- 19.**Secure the securing bracket to the wall using the screws (supplied).

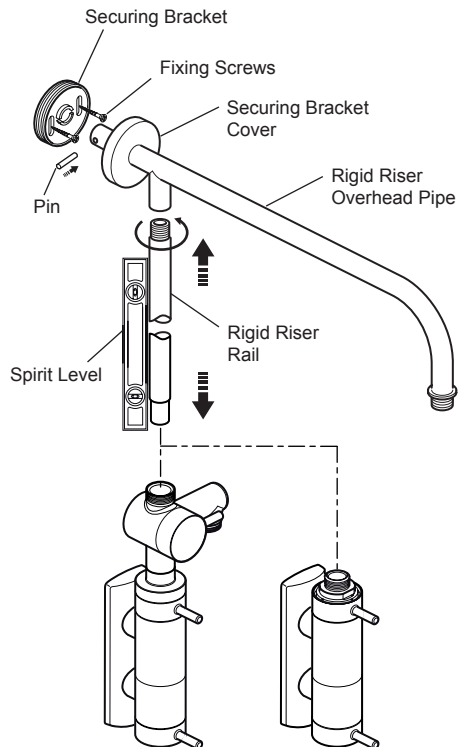

20. For **ER** models slide the concealing plate, compression nut and olive onto the rigid riser rail and locate it into the mixer outlet.
21. For **ERD** models slide the clamp bracket, hose retaining ring, compression nut and olive onto the rigid riser rail and locate it into the diverter outlet.
22. Make sure that the securing bracket cover is fitted onto the rigid riser overhead pipe, then fix the pipe to the securing bracket with the pin. Screw the securing bracket cover over the securing bracket.
23. Tighten the compression nut using a suitable spanner.
- Note!** Hold the diverter in position whilst tightening the compression nut.
24. For **ER** models slide the concealing plate down the rigid riser rail to cover the compression nut.

25. For **ERD** models:

- 25.1 Screw the hose onto the outlet of the diverter, making sure that the hose seal is fitted.
- 25.2 Pass the flexible hose through the hose retaining ring and screw the remaining end of the hose onto the showerhead making sure that the hose seal is fitted.
- 25.3 Place the showerhead in the clamp bracket.

26. Make sure that the hose washer is fitted and screw the deluge head onto the rigid riser overhead pipe.

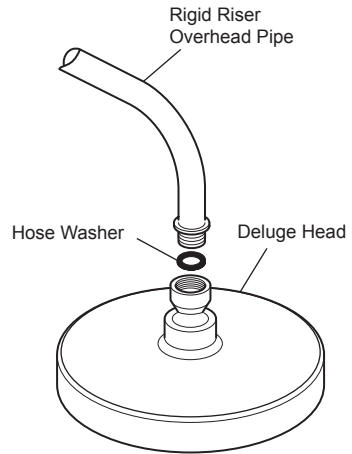
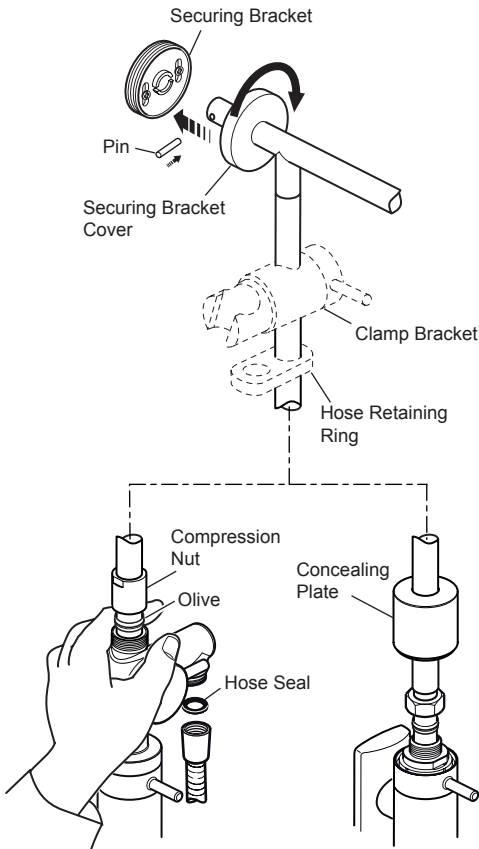

27. Turn on the hot and cold water supplies and check for leaks.
28. Before using the shower, refer to section: **'Commissioning'**.

## COMMISSIONING

### Maximum Temperature Setting

Before using the shower the maximum temperature must be checked to make sure that it is at a safe level. It has been preset to approximately 43°C at the factory but due to variations in site conditions the maximum temperature may need adjustment.

**Note!** Make sure that the hot water temperature is at least 55°C and that there is sufficient supply.

1. Turn on the mixer to the maximum temperature (i.e. fully clockwise) and allow the temperature to stabilise.
2. Test that the temperature of the water from the shower outlet is hot enough.  
If the temperature is too hot or too cold adjust as follows:
3. Carefully remove the concealing cap using a suitable tool (i.e. stanley knife / thin blade).
4. Loosen the securing screw (do not remove fully) and pull down the temperature lever to disengage from the control gear.
5. Rotate the temperature lever anti-clockwise (one serration), re-engage with the control gear and return to the maximum temperature stop. Check the temperature, if it is still not hot enough repeat the procedure.

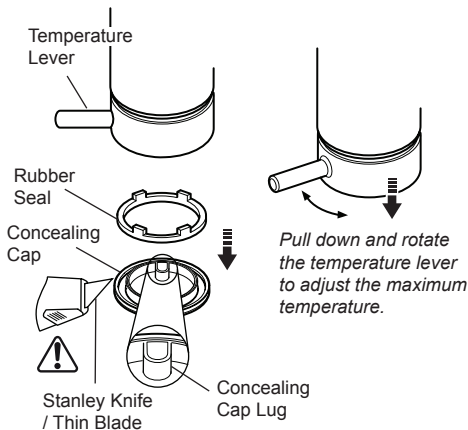

6. Once the maximum temperature is satisfactory, tighten the securing screw.
7. Refit the concealing cap with the lug at the back (i.e. nearest the wall) make sure that the rubber seal is correctly fitted and the concealing cap is pushed fully on.

## OPERATION

**Caution!** Care is required when adjusting flow, diverting to different outlets or adjusting temperature. Make sure that the temperature has stabilised.

### Operating the Divertor

**(ERD Models Only)** The flow is switched between the deluge head, the showerhead and both together by rotating the divertor knob.

**Note!** On gravity fed / other low pressure systems with both outlets operating, the height of the showerhead may affect the flow from the deluge head.

### Flow Control

Turn the flow lever anticlockwise to the maximum flow.

### Temperature Control

Turn the temperature control lever anticlockwise to decrease the temperature and clockwise to the preset maximum temperature

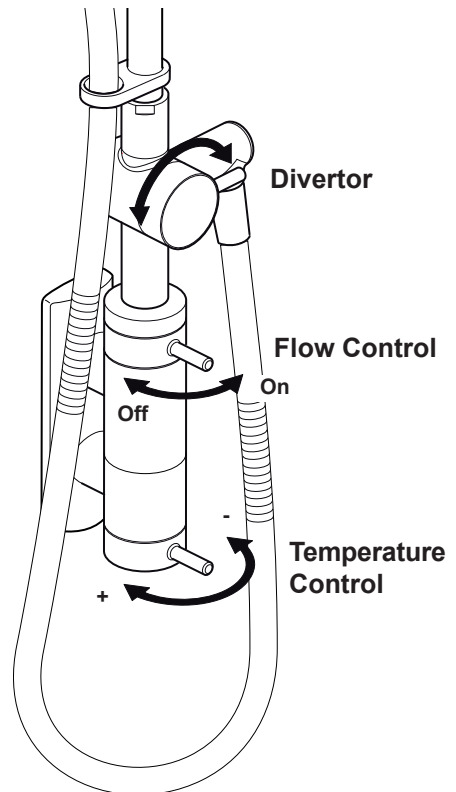

## USER MAINTENANCE

If you require a Mira trained service engineer or agent, refer to section: '**Customer Services**'.

### Fault Diagnosis

#### Symptom:

- *Only hot or cold water from the mixer outlet.*
- *Outlet temperature too hot / too cold.*

#### Cause Rectification:

- *Inlets reversed (hot supply to cold supply). Rework inlet pipework.*
  - *No hot water reaching mixer.*
  - *Check the filters for any blockage.*
  - *Installation conditions outside operating parameters, refer to sections: '**Specifications**' and '**Commissioning**'.*
- 

#### Symptom:

- *Fluctuating or reduced flow rate.*

#### Cause Rectification:

- *Check the showerhead, hose and filters for any blockage.*
  - *Make sure that the maintained inlet pressures are nominally balanced and sufficient, refer to section: '**Specifications**'.*
  - *Make sure that the inlet temperature differentials are sufficient, refer to section: '**Specifications**'.*
  - *Flow regulator fitted incorrectly.*
  - *Air lock or partial blockage in the pipework.*
- 

#### Symptom:

- *Water leaking from showerhead.*

#### Cause Rectification:

- *Normal for a short period after shut off.*
- *Check that the pressures are not in excess of the specifications for the product.*
- *Renew the mixer valve assembly.*

### Lubricants

Silicone based lubricants must only be used on the rubber seals.

**Caution!** Oil based or other lubricant types may cause rapid deterioration of seals.

### Cleaning

The chrome plated parts should be cleaned using a mild washing up detergent or soap solution, rinsed and then wiped dry with a soft cloth.

**Warning!** Many household cleaners contain abrasive and chemical substances, and should not be used for cleaning plated or plastic fittings.

These finishes should be cleaned with a mild washing up detergent or soap solution, and then wiped dry using a soft cloth.

Use your thumb or a soft cloth to wipe any limescale from the soft nozzles and the front surface of the showerhead spray plate.

**Do not** use descalents on this product.

# SPARE PARTS

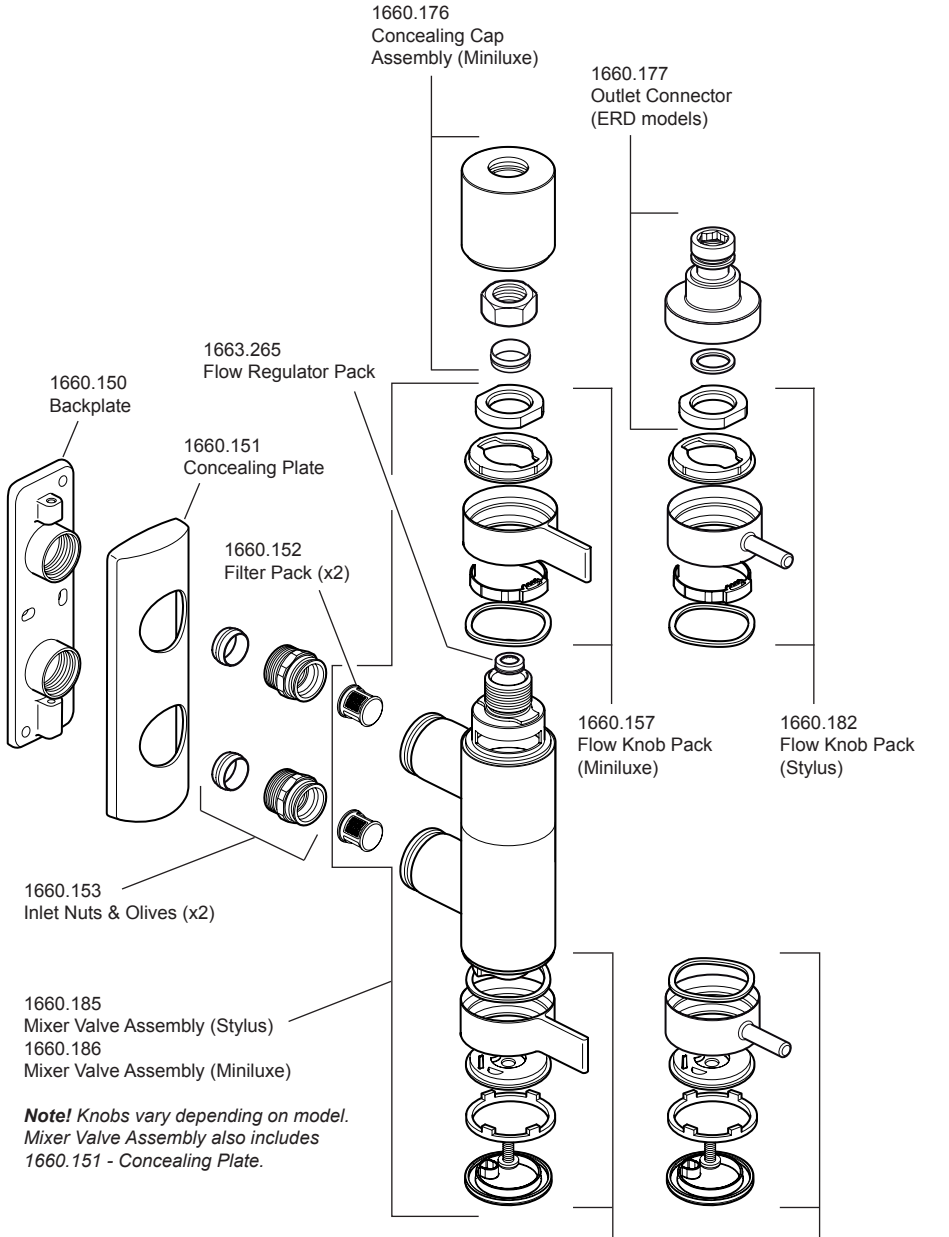

Not illustrated:  
1660.159 Screw Pack  
1660.175 Seal Pack

1660.155  
Temperature Knob  
Pack (Miniluxe)

1660.182  
Temperature Knob  
Pack (Stylus)

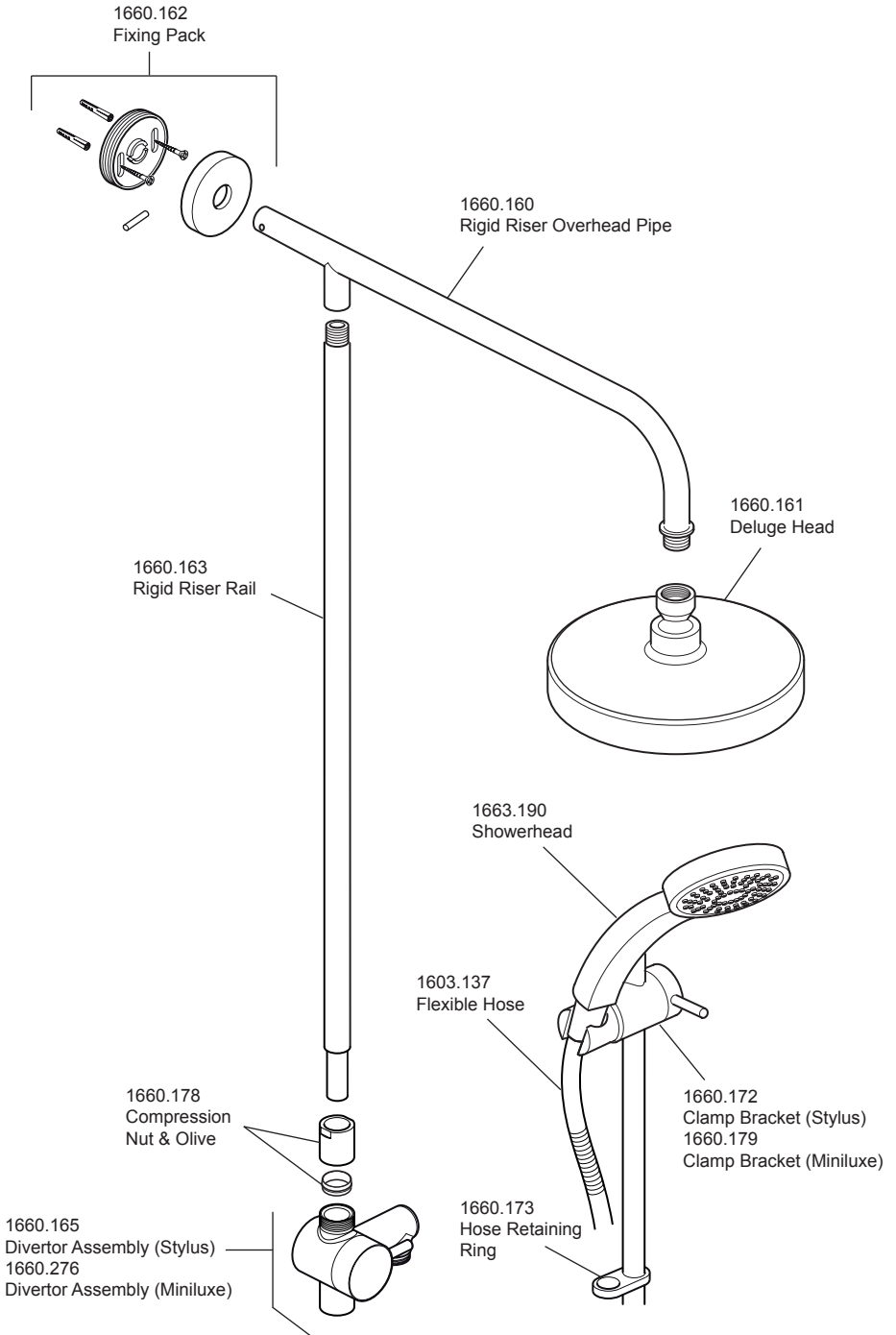

## ACCESSORIES

Genuine Mira accessories can be purchased direct from Customers Services (our contact details can be found on the back cover of this guide) or from approved stockists or merchants.

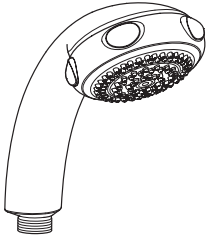

### **Eco Showerhead**

**White - 2.1668.001**

**Chrome - 2.1668.002**

The Eco shower head gives you an invigorating shower, but reduces water consumption and heating costs.

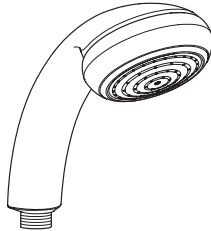

### **Everclear Showerhead**

**White - 2.1616.030**

**Chrome - 2.1616.031**

Mira's new Everclear range has been specially designed for hard water areas and reduces the risk of lime scale build up.

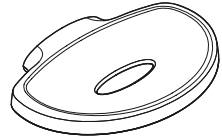

### **Wall Mounted Soap Dish**

**White - 1.1540.278**

**Chrome - 1.1540.279**

Wall mounted for use anywhere in, or outside the showering area.

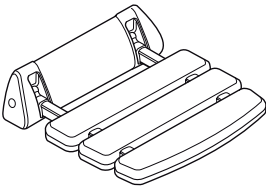

### **Shower Seat**

**White - 2.1536.128**

**White/Chrome - 2.1536.129**

For use in or out of the showering area. **Note!** Must be installed onto a solid wall.

Shower seat folds up when not in use



NOTES

NOTES

NOTES

# CUSTOMER SERVICE

## Guarantee

Your product has the benefit of our manufacturer's guarantee which starts from the date of purchase.

To activate this guarantee, please return your completed registration card, visit our website or free phone 0800 0731248 within 30 days of purchase (UK only).

Within the guarantee period we will resolve defects in materials or workmanship, free of charge, by repairing or replacing parts or product as we may choose.

**This guarantee is in addition to your statutory rights and is subject to the following conditions:**

- The product must be installed and maintained in accordance with the instructions given in this user guide.
- Servicing must only be undertaken by us or our appointed representative. **Note!** if a service visit is required the product must be fully installed and connected to services.
- Repair under this guarantee does not extend the original expiry date. The guarantee on any replacement parts or product ends at the original expiry date.
- For shower fittings or consumable items we reserve the right to supply replacement parts only.

**The guarantee does not cover:**

- Call out charges for non product faults (such as damage or performance issues arising from incorrect installation, improper use, lack of maintenance, build up of limescale, frost damage, corrosion, system debris or blocked filters) or where no fault has been found with the product.
- Water or electrical supply, waste and isolation issues.
- Compensation for loss of use of the product or consequential loss of any kind.
- Damage or defects caused if the product is repaired or modified by persons not authorised by us or our appointed representative.
- Routine maintenance or replacement parts to comply with the requirements of the TMV 2 or TMV 3 healthcare schemes.

## What to do if something goes wrong

If your product does not function correctly when you first use it, contact your installer to check that it is installed and commissioned in accordance with the instructions in this manual.

Should this not resolve the issue, contact our Customer Services Team who will offer you or your installer advice and if applicable arrange for a Service Technician to call.

If the performance of your product declines, check in this manual to see if simple home maintenance is required. If you require further assistance call our Customer Services Team.

## Extended Guarantees

A selection of protection plans are available that enable you to cover repair bills for the life of your policy (excludes Eire). Ring 01922 471763 for more details.

## Helpdesk Service

Our dedicated Customer Services Team is comprehensively trained and can offer help and advice, spare parts, accessories or a service visit. We will need you to have your model name or number, power rating (if applicable) and date of purchase. As part of our quality and training programme calls may be recorded or monitored.

## Mira Showers Website ([www.mirashowers.co.uk](http://www.mirashowers.co.uk))

From our website you can register your guarantee, download additional user guides, diagnose faults, purchase our full range of accessories and popular spares, refer to our FAQ's and request a service visit.

## Spares and Accessories

We maintain extensive stocks of genuine spares and accessories and aim to provide support throughout the product's expected life. Payment can be made by phone at time of order using most major Credit or Debit cards and we aim to despatch orders within two working days. Items purchased from us are guaranteed for 12 months from date of purchase. For safety reasons spares exposed to mains voltages should only be fitted by competent persons.

**Returns** – items can be returned within one month of date of purchase, providing that they are in good condition and the packaging is unopened. Please obtain authorisation from our Customer Services Team before return. We reserve the right to apply a 15% restocking charge.

## Service / Repairs

We have a nationwide team of Service Technicians who can carry out all service or repair work to your product within the guarantee period and beyond. You have the assurance of a fully trained Mira Technician, genuine Mira spare parts and a 12 month guarantee on any chargeable work done.

Payment should be made directly to the Service Technician who will accept most major Credit or Debit cards.

## To Contact Us

### UK

**Telephone: 0844 571 5000**

Mon to Fri 8:00 am - 5:30 pm, Sat 8:30 am - 3:30 pm

E-mail: [technical@mirashowers.com](mailto:technical@mirashowers.com)

Fax: 01242 282595

By Post: Mira Customer Services Dept, Cromwell Road, Cheltenham, Gloucestershire, GL52 5EP

### Eire

**Telephone: 01 459 1344**

Mon to Fri 9:00 am - 5:00 pm

E-mail: [sales@modernplant.ie](mailto:sales@modernplant.ie)

Fax: Dublin 01 459 2329

By Post: Modern Plant Ltd (Dublin), Otter House, Naas Road, Clondalkin, Dublin 22

Mira is a registered trade mark of  
Kohler Mira Limited.

The company reserves the right to alter  
product specifications without notice.



**mira**  
SHOWERS