

**Concealed Individual Stop Tap &
Thermostatic Control Valve with diverter**

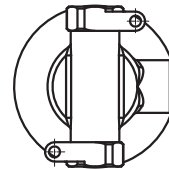
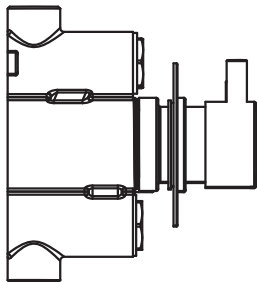
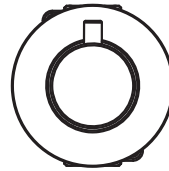
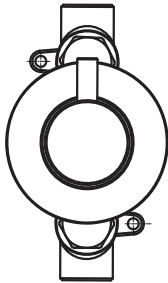

Fitting Instructions

Please follow them carefully and
leave this manual with end user

Installation Guide

Before you begin:

1. **We recommend that this product is installed by a qualified tradesperson,** Victorian Plumbing Ltd. accept no liability for products incorrectly installed, or where the correct testing procedures have not been adhered to, thus resulting in the escape of water and consequential damage.
2. Ensure the incoming mains water supply is switched off prior to commencing the installation.
3. Observe all local plumbing and building codes & regulations.
4. Unpack the product then read these instructions before proceeding. Inspect the product for damage. If any damage is found, contact our Customer Relations team.

Installation:

1. Determine the fixing position for the valve and make a recess in the wall to house the valve. The depth of the recess should be 80mm to 100mm below the finished wall surface to fit the cover plate correctly.
2. Insert the valve into the wall recess, then mark the fixing points with the mounting lugs that are cast on the valve body. Pull the valve out and drill suitable length holes at the marked positions. Use supplied plugs and screw to secure the valve.
3. Now that the show body is securely mounted to the wall (prior to installation and connecting) make sure that the pipes are thoroughly flushed to remove and debris etc. (failure to do this will impair the flow of the water).
4. The Plumbing connections should then be made to the hot and cold inlets which are clearly marked. The hot water inlet is to be connected with the hot supply and the cold water inlet is to be connected to the cold supply. Make sure that they are correctly connected, otherwise the thermostatic cartridge will lose its function of controlling the temperature and may scald.
5. Make the plumbing connection to the water outlet. This will take the water to the chosen shower kit you have selected to run with this shower.
6. The plumbing connections on the inlets are all 1/2" BSP female threads. It is recommended to apply PTFE tape to all thread connections.
7. Turn on the water supply to ensure that there are no leakages.
8. Slide the plate into position over the lock sleeves and fit this up against the wall surface.
9. Fit the control handles. Make sure the blue markings on the stop lug of above stop ring and the below stop ring should be in line. Remove the decorative caps/handle lever, then place the handle on the above stop ring, hold the handle firmly in position and tighten the set screw with supplied Allen key. Be careful not to turn the above stop ring. Refit the decorative caps/handle lever. The thermostatic control handle is clearly marked with H & C.

Diagram:

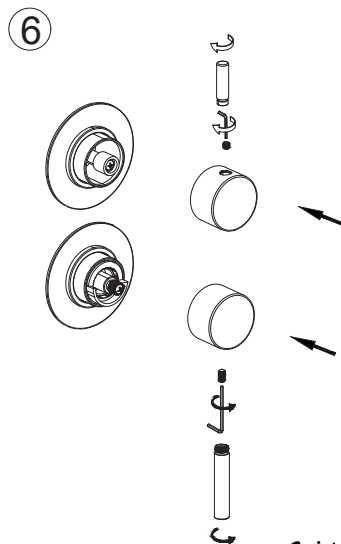
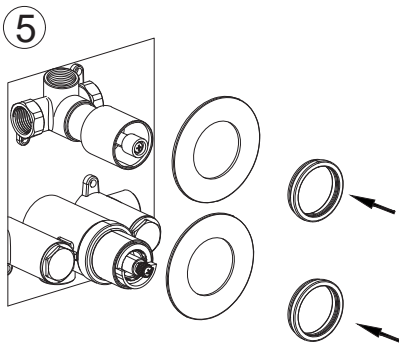
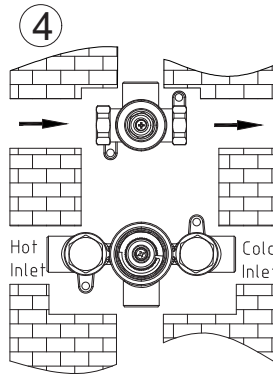
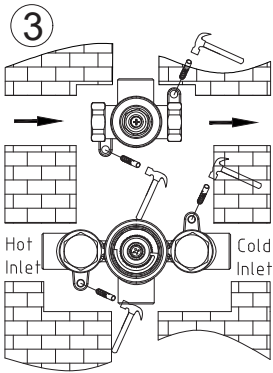
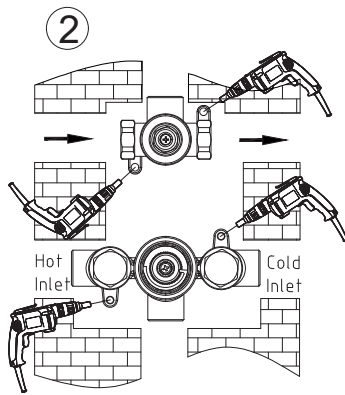
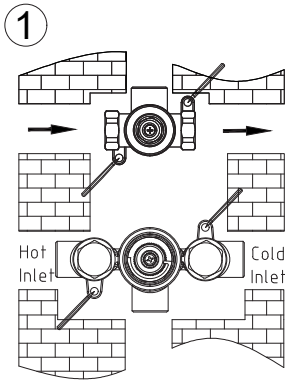

Operation Notice:

1. The work condition for use of this product is cold water 4-29°C, hot water 55-85°C and water pressure 0.5 bar - 5 bar. To avoid the differential pressure between hot water and cold water, the thermostatic cartridge is preferably under the condition of water pressure 3 bar, hot water 65°C and cold water 15°C .
2. Make sure the shower valve is off when no water comes out of it (especially when nobody resides in the house or during the period of decoration or the absence of water).
3. When the room temperature drops below 0°C , take necessary measures (such measures as keeping shower valve warm and closing windows) to prevent the shower valve from being frozen or even broken (especially when windows kept open for air ventilation while nobody resides in).
4. Do not disassemble the valve unless you are an expert.

Maintenance:

If the water flow is less than normal and temperature control is imprecise after a period of usage. It is often due to the poor water which blocks the small filter net. The cleaning method At first, turn off the main valve. Remove the control handles and cover plate. Then unscrew the end caps on the hot/cold water inlet sides of valve body with an Allen key. Now you can clean the small filter net with brush and vinegar. After completion, rinse it and reassemble all the parts back. At last, check the water flow and temperature control.

Temperature Adjustment:

1. The maximum temperature is factory set at 38°C. If you think it is not enough, you can adjust the above stop ring position to get a higher maximum temperature.
2. Remove the handle on the thermostatic control. The spline and above stop ring will be shown.
3. Remove the above stop ring by loosening the set screw. Turn the shower flow control fully on.
4. Do not turn the spline. Turn the above stop ring clockwise, then place it back. The maximum temperature will be higher. Allow water temperature to stabilise and check temperature. The maximum temperature must never exceed 46 °C.
5. Achieve the temperature you want, turn the flow control off. And refit the handle.

Aftercare:

Always clean the surface of shower valve to keep it bright. **Attention:** please do not use inappropriate tools such as sharp brushes, rough sponges, scouring pads or corrosive detergent to clean the shower valve. Please clean the shower valve by wet cloth and soapy water after each time of usage. Then rinse the soap out with clean water and dry with a soft cotton cloth.

Exploded Diagram

Diverter Valve:

Note: Please Insure The Lock Ring Is Tight Before Shower Is Used For The First Time.

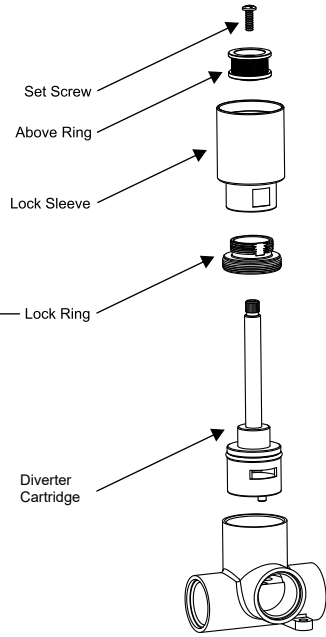

Thermostatic Valve:

Note: Please Insure The Lock Ring Is Tight Before Shower Is Used For The First Time.

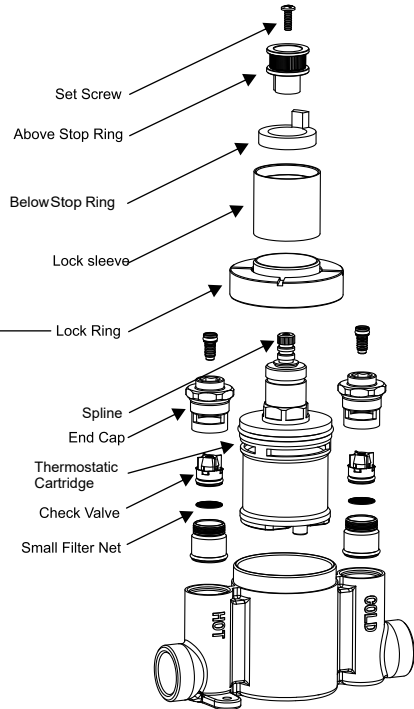

Troubleshooting

FAULT	POSSIBLE CAUSE
Shower only runs hot or cold after installation	<ol style="list-style-type: none">1. Hot and cold supplies have been plumbed the wrong direction.2. Faulty thermostat.3. Insufficient water pressure.
Shower does not run hot enough	<ol style="list-style-type: none">1. Check the hot water supply temperature.2. Maximum temperature needs adjusting, see temperature adjustment.3. Blockage in the hot supply.
Hot water in cold supply or vice versa	<ol style="list-style-type: none">1. Check and clean non-return valves.2. Check Hot and Cold supplies have not been reversed during installation.
Low or no flow	<ol style="list-style-type: none">1. Possible blockage/debris in the system.2. Operating conditions are incorrect.3. Valve shut off has been activated due to a pressure drop in either the cold or hot supplies.
Leaking when in the off position	<ol style="list-style-type: none">1. Debris in the flow control cartridge.2. Faulty control cartridge.
Fluctuating flow	<ol style="list-style-type: none">1. Dynamic inlet pressure are not balanced.

Notes:

www.victorianplumbing.co.uk