

Bar Valve Calibration

The Shower Valve temperature is pre-set to 43°C, but on certain installations the temperature may need to be adjusted.

Note: Ensure hot water supply is above 60°C.

Turn the Flow Control Handle to the maximum flow.

Turn the temperature control handle fully anti-clockwise & check the temperature of the water from the outlet. If the temperature is not set to 43°C continue below.



1. Remove the Temperature Handle Lever.



2. Using a 2.5mm Allen key, remove the Temperature Handle retaining grub screw.

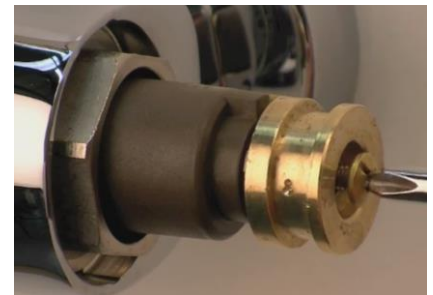

3. Using a X-head screwdriver, remove the Temperature Stop Lug.



4. Relocate the Temperature Stop Lug back onto the Cartridge Spline by approx. 2-3mm in order to adjust the temperature.



5. If the pre-set temperature is too hot, turn the Temperature Stop Lug towards the cold (clockwise) and wait approx. 10 seconds.



6. If the pre-set temperature is too cold, turn the Temperature Stop lug towards the hot and wait approx. 10 seconds.



7. Once the Shower is set to the desired temperature, relocate the Temperature Stop Lug onto the Cartridge Spline, ensuring that the Brass Pin is against the Temperature Stop Point of the Temperature Cartridge Cap, and secure with the X-head screw. (This prevents the temperature from exceeding 43°C).



8. Again using the 2.5mm Allen key, re-attach the Temperature Handle.



9. Re-fit the Temperature Handle Lever.

Alternatively you can view the full video by going to;
<http://www.hudsonreed.co.uk/technical>

Or, simply scan the below QR code with any Smartphone device.



Body and handle
design may vary
depending on
model chosen

Thermostatic Bar Valves

Installation & operating guide

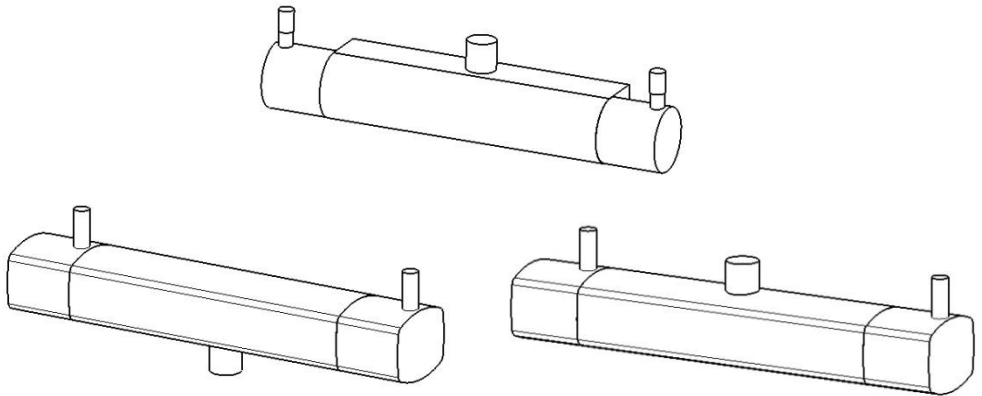

**Please leave this installation & user guide with the
end user**



CONTENTS

1.	Product Variants	1
2.	Important information	2
3.	Cleaning & Aftercare	3
4.	Box contents	3
5.	Dimensions	4
6.	Plumbing connections	4-5
7.	Installation	5
8.	Temperature adjustment	6
9.	TMV2 Conditions of Use & Commissioning	7-8
10.	Fault diagnosis	9
11.	Contact Details	9

1. PRODUCT VARIANTS

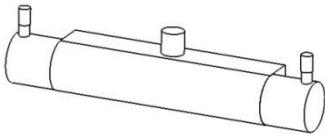

A3500 (VQ6) - Outlet is interchangeable between top and bottom.

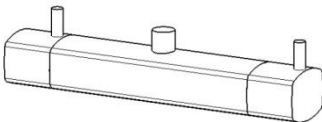

A3502 (VQ7) - Top Outlet Only

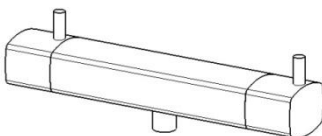

A3503 (VQ9) - Bottom Outlet Only

2. IMPORTANT INFORMATION

- Thank you for purchasing this high quality Thermostatic Bar Shower Valve (BUILDCERT Code VQ6, VQ7 & VQ9). To ensure you get the very best use from this product, please read this installation guide thoroughly.
- These shower valves have separate controls for temperature & water flow control, and have been designed for Exposed wall installations. The product is suitable for use on all plumbing systems including gravity, pumped, fully modulating combination boilers and unvented systems.
- Please make sure that any auxiliary products (e.g. shower kits) are suitable for connection to this product.
- Debris in the new pipe work can get into the cartridges. This is easily avoided by thoroughly flushing the pipe work **BEFORE** connecting the shower valve to the water supplies.
- This shower valve is suitable for use with all water supply systems up to a maximum water pressures of 5 bar (**balanced water pressures are desirable for best performance**). Pressures above this limit may require the fitting of pressure reducing valves into the incoming mains household water supply.
- This product must be installed in such a way as not to cause water damage during use. **We recommend that this product is fitted by a fully qualified installer. The installation must comply with all current water byelaws.**
- **NB. If you experience any difficulty with the installation or operation of your new shower valve, please refer to 'Fault Diagnosis' at the back of this guide.**

3. CLEANING & AFTER CARE

This product is made using high quality chrome plating, and this should be maintained using a clean damp cloth. No abrasive agents or materials should be used, and **any misuse will invalidate your guarantee.**

This precision made thermostatic shower valve will continue to give years of use provided it has been installed & operated in accordance with these fitting instructions. Failure to do this will invalidate any guarantees.

4. BOX CONTENTS

Note: Body, plate and outlet position may vary depending on the model supplied.

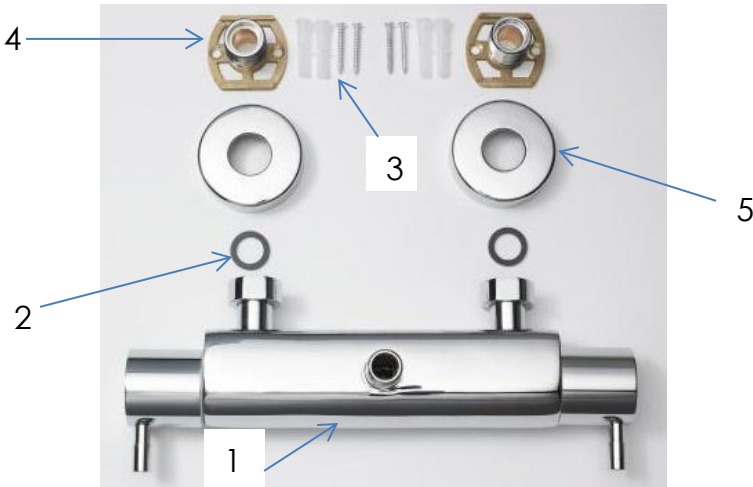

1. Main thermostatic shower valve body with built in check valves.
2. Rubber sealing washers x 2.
3. Screws and wall plug pack x 2.
4. Fast fix 15mm compression to 3/4" BSP connectors x 2.
5. Chrome wall flanges x 2.

Other items that you will require which are not supplied include (this is not an exhaustive list): Isolation valves, Screwdrivers, Adjustable Wrench, Bucket (for flushing out pipework), Thermometer, Silicone and a Spirit level.

5. DIMENSIONS

ALL DIMENSIONS ARE APPROXIMATE

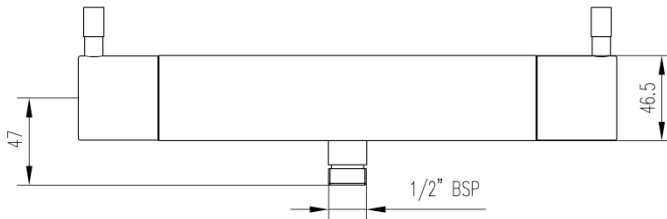
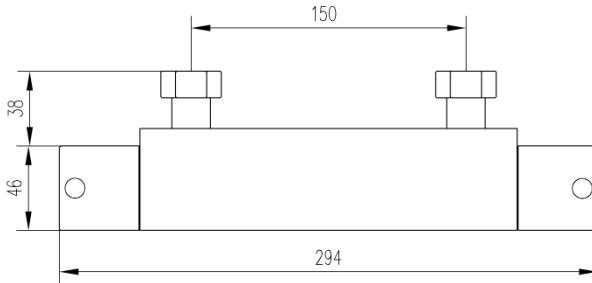

6. PLUMBING CONNECTIONS

The inlets will be clearly marked hot and cold. Always connect the hot pipework to the hot side of the valve and the cold pipework to the cold side of the valve. The pipework on site should be installed with the hot on your left hand side and the cold on your right hand side when you face the wall.

Depending on the product, the outlet will be:

1. **Top only:** When installed correctly the outlet will be at the top.
2. **Bottom only:** When installed correctly the outlet will be at the bottom.
3. **Top or bottom:** The outlet is removable and can be installed on the top or the bottom. Remove the outlet and the cap on the opposite side and switch their positions.

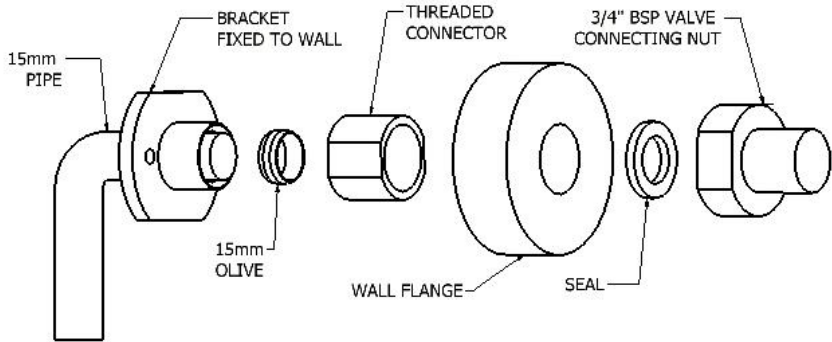

7. INSTALLATION

1. You must install isolation valves in an accessible position on the HOT & COLD water supply lines for servicing purposes. Check valves are already installed in the connecting nuts.
2. Determine the fixing position for the shower valve.
3. The pipework must protrude through the wall at this fixing position.
4. Fit the water inlet pipes through the fast fix brackets, screw the brackets to the wall and make a compression fitting with the chrome threaded nut.
5. Make sure the pipework is thoroughly flushed through to remove any debris from the system before connecting the water supplies. Failure to do this could invalidate the guarantee.
6. Fix the shower valve body to the connectors fitted on the wall by using the captive nuts.
7. Make the plumbing connection to the water outlet. This will take the water to the chosen auxiliary product (shower kit) you have selected to run with this shower.
8. Turn on the water supply and check for leaks.
9. Turn the flow handle to the on position and turn the temperature handle anticlockwise until it comes to a stop. Do not force it. After a few minutes, check the temperature from the terminal outlet with a thermometer. The recommended temperature is 41°C. If the temperature is not 41°C please consult the temperature adjustment section.
10. The valve can now be commissioned. See the TMV2 conditions of use and commissioning section.

8. TEMPERATURE ADJUSTMENT

1. The water flow handle should be on your left and the temperature control on your right as you look at the valve. Turn the flow handle to the on position and turn the temperature handle anticlockwise until it comes to a stop. Do not force it. After a few minutes, check the temperature from the terminal outlet with a thermometer. The recommended temperature is 41°C. If you need to adjust the temperature please continue.
2. Turn off the water flow. Unscrew the handle peg without damaging the chrome. Then, unscrew the grub screw using a suitable Allen Key.

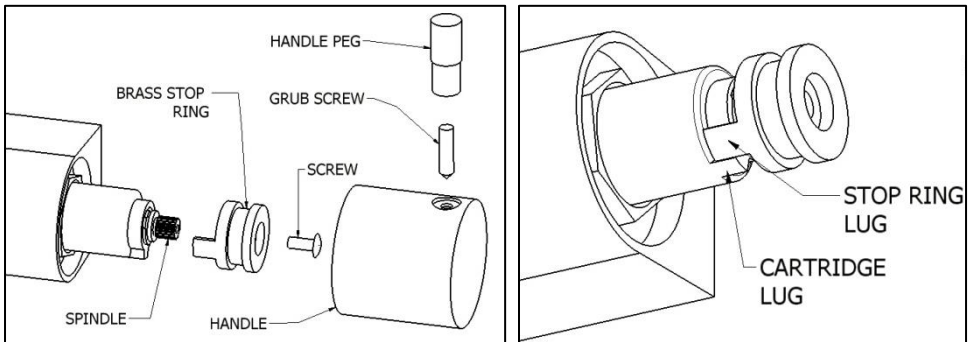

3. Remove the screw and the brass stop ring. In order to set the max temperature, please turn the spindle anticlockwise to increase the temperature and clockwise to decrease the temperature. After every adjustment turn the water flow back, wait a few minutes and measure the temperature with the thermometer.
4. When the desired max temperature has been reached, please replace the brass stop ring, with the stop lug against the cartridge stop lug as in the diagram. This stops the spindle turning any further anti clockwise, preventing the temperature from going above the max set point that has just been set.
5. Replace the handle and precede to the TMV2 conditions of use and commissioning section.

9. TMV2 CONDITIONS OF USE & COMMISSIONING

Conditions of use for Type 2 valves:

	High Pressure	Low Pressure
Maximum Static Pressure – Bar	10	10
Flow Pressure, Hot & Cold - Bar	0.5 to 5	0.1 to 1
Hot Supply Temperature - °C	55 to 65	55 to 65
Cold Supply Temperature - °C	Equal to or Less than 25°	Equal to or less than 25°

NOTE: Valves operating outside these conditions cannot be guaranteed by the Scheme to operate as Type 2 valves.

Designation of use:

High Pressure Bidet, Shower, Washbasin.

Low Pressure Shower.

Recommended outlet temperatures

The BUILDCERT TMV scheme recommends the following set maximum mixed water outlet temperatures for use in all premises:

44°C for bath fill but see notes below;

41°C for showers;

41°C for washbasins;

38°C for bidets.

The mixed water temperatures must never exceed 46°C. The maximum mixed water temperature can be 2°C above the recommended maximum set outlet temperatures.

Note:

46°C is the maximum mixed water temperature from the bath tap. The maximum temperature takes account of the allowable temperature tolerances inherent in thermostatic mixing valves and temperature losses in metal baths. It is not a safe bathing temperature for adults or children. The British Burns Association recommends 37 to 37.5°C as a comfortable bathing temperature for children. In premises covered by the Care Standards Act 2000, the maximum mixed water outlet temperature is 43°C.

The thermostatic mixing valve will be installed in such a position that maintenance of the TMV and its valves and the commissioning and testing of the TMV can be undertaken.

The fitting of isolation valves is required as close as is practicable to the water supply inlets of the thermostatic mixing valve.

Commissioning notes for Thermostatic Mixing Valves.

The first step in commissioning a thermostatic mixing valve is to check the following:

1. The designation of the thermostatic mixing valve matches the application.
2. The supply pressures are within the valves operating range.
3. The supply temperatures are within the valves operating range.
4. Isolating valves (and strainers preferred) are provided.

If all these conditions are met, proceed to set the temperature as stipulated in the manufacturer installation instructions.

It is a requirement that all TMV2 approved valves shall be verified against the original set temperature results once a year. When commissioning/testing is due the following performance checks shall be carried out.

Measure the mixed water temperature at the outlet.

Carry out the cold water supply isolation test by isolating the cold water supply to the TMV, wait for five seconds if water is still flowing check that the temperature is below 46°C. If there is no significant change to the set outlet temperature ($\pm 2^\circ\text{C}$ or less change from the original settings) and the fail-safe shut off is functioning, then the valve is working correctly and no further service work is required.

Note:

If there is a residual flow during the commissioning or the annual verification (cold water supply isolation test), then this is acceptable providing the temperature of the water seeping from the valve is no more than 2°C above the designated maximum mixed water outlet temperature setting of the valve.

Temperature readings should be taken at the normal flow rate after allowing for the system to stabilise.

The sensing part of the thermometer probe must be fully submerged in the water that is to be tested.

Any TMV that has been adjusted or serviced must be re-commissioned and re-tested in accordance with the manufacturers' instructions.

The installation of thermostatic mixing valves must comply with the requirements of the Water Supply (Water Fittings) Regulations 1999.

10. FAULT DIAGNOSIS

FAULT	POSSIBLE CAUSE
After installation, shower only runs HOT or COLD.	1. Hot and cold water supplies are plumbed to the wrong sides of the valve.
Shower will not run hot enough when first installed.	1. Check Hot Water supply temperature. 2. Maximum temperature needs adjusting. See Temperature Adjustment section above. 3. Operating Conditions are incorrect. 4. Blockage in hot side of the system.
Hot water in cold & vice versa	1. Make sure serviceable in line check valves have been fitted. Check & clean them if they are already installed.
Low or no flow from the Valve	1. Possible blockage in the system. 2. Operating Conditions are incorrect. 3. Valve being obstructed by debris. 4. Valve shut off has activated due to Operating Conditions.
Leak from valve in the off position	1. Debris has gotten into the CD valve.
Fluctuating Flow Rate	1. Possible blockage in the system. 2. Operating conditions are incorrect. 3. Dynamic inlet pressures are not balanced. 4. Shuttle assembly is faulty.

11. CONTACT DETAILS

Please do not contact Customer Care until the Fault Diagnosis Chart has been consulted. Please ensure the valve has been installed within the recommended operating conditions. If you still require assistance please contact customer care using the details below:

Ultra Finishing Ltd,
Widow Hill Road,
Heasandford Industrial Estate,
Burnley, Lancashire,
BB10 2BQ.
Customer Care Tel: 01282 446789