

**1850mm AND 1950mm FRAMED WETROOM  
SCREEN FITTING INSTRUCTION**

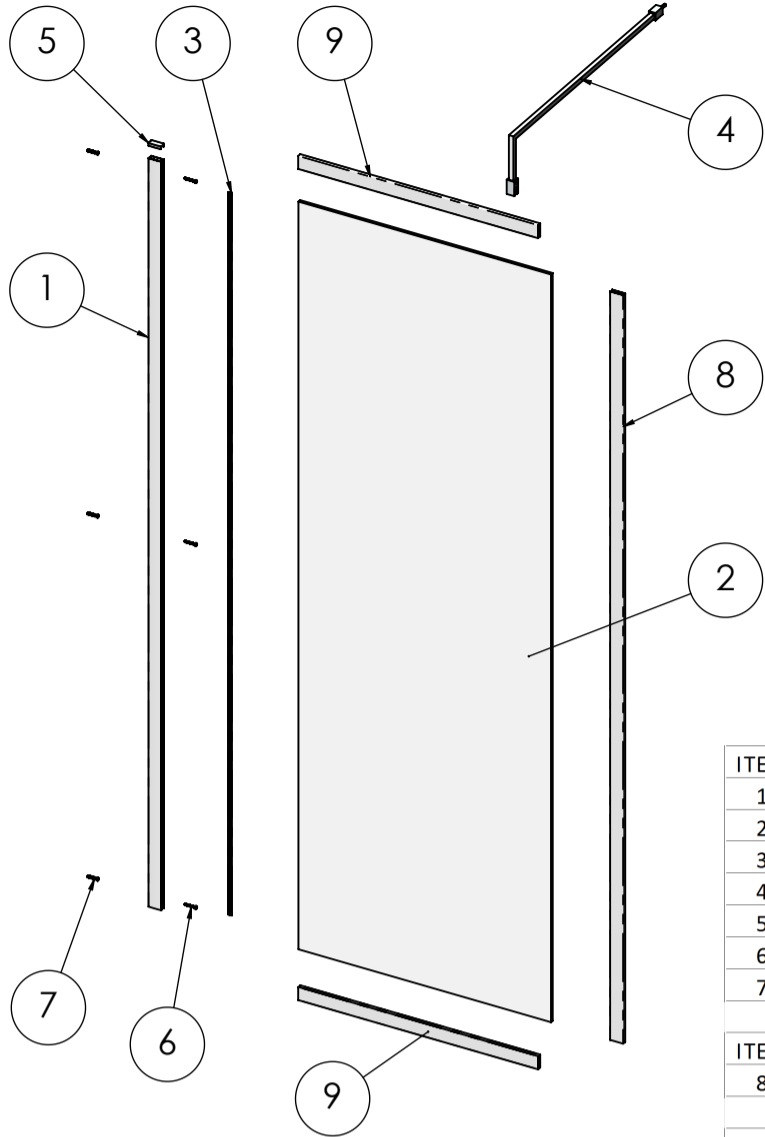

**NOTE A:** SUPPLIED AS x1 ONE LONG PROFILE FOR SCREENS UPTO 900mm. THIS WILL NEED CUTTING INTO THE REQUIRED x2 PIECES

SUPPLIED AS x2 LONG PROFILES FOR SCREENS OVER 900mm. THEY WILL BOTH NEED CUTTING TO LENGTH

UNPACK THE BOX AND ENSURE ALL COMPONENTS ARE PRESENT.

NO REFUNDS OR REFITTING COST WILL BE GIVEN IF INCOMPLETE OR DAMAGED GOODS ARE FITTED.

THE TOUGHENED SAFETY GLASS IS MANUFACTURED TO SPECIFICATION EN12150-1 AND SHOULD BE HANDLED WITH CARE AS IMPACTS CAN DAMAGE THE GLASS AND CAUSE IT TO FAIL AT A LATER DATE.

FIT THE SHOWER TRAY AS PER THE MANUFACTURERS INSTRUCTIONS.

NOTE: IF THE TRAY ISN'T TRUE AND LEVEL, IT MUST BE RECTIFIED BEFORE FITTING THE SCREEN.

ALLOW THE TRAY SILICONE TO CURE BEFORE FITTING THE SCREEN.

USE SUITABLE FIXINGS FOR THE SUBSTRATE YOU'RE FIXING TO. THE ONES SUPPLIED ARE GENERAL-PURPOSE.

**TOOLS REQUIRED**

- POWER DRILL - 6mm MASONRY DRILL BIT
- CROSS HEAD SCREW DRIVER
- TAPE MEASURE - PENCIL
- SILICONE GUN
- SANITARY GRADE SEALANT
- SPIRIT LEVEL.

ITEM	DESCRIPTION	QTY	NOTE
1	WALL PROFILE	1	
2	GLASS PANEL	1	
3	PUSH IN V SEAL	1	
4	TOP BAR ASSEMBLY	1	
5	TOP CAP	1	
6	WALL SCREWS	3	
7	WALL PLUG	3	

ITEM	DESCRIPTION	QTY	NOTE
8	PUSH ON VERTICAL PROFILE	1	SEE STEP 3

ITEM	DESCRIPTION	QTY	NOTE
9	PUSH ON HORIZONTAL PROFILE. SCREENS UPTO 900mm	1	SEE NOTE A
	PUSH ON HORIZONTAL PROFILE. SCREENS OVER 900mm	2	

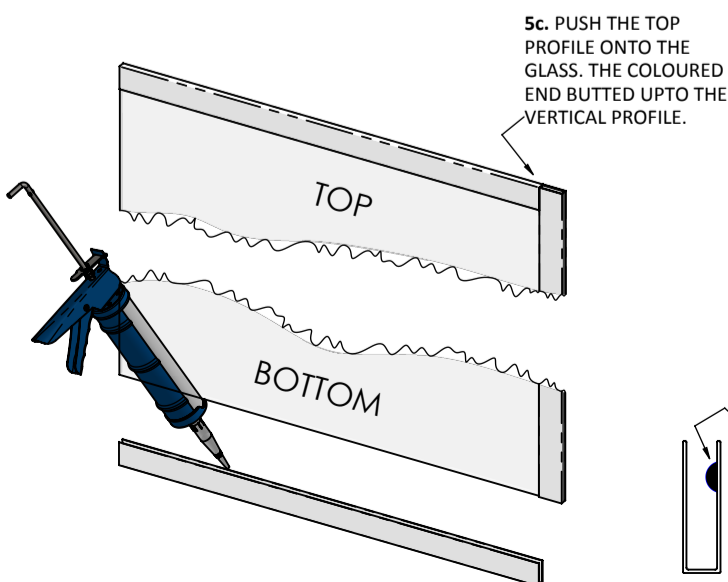
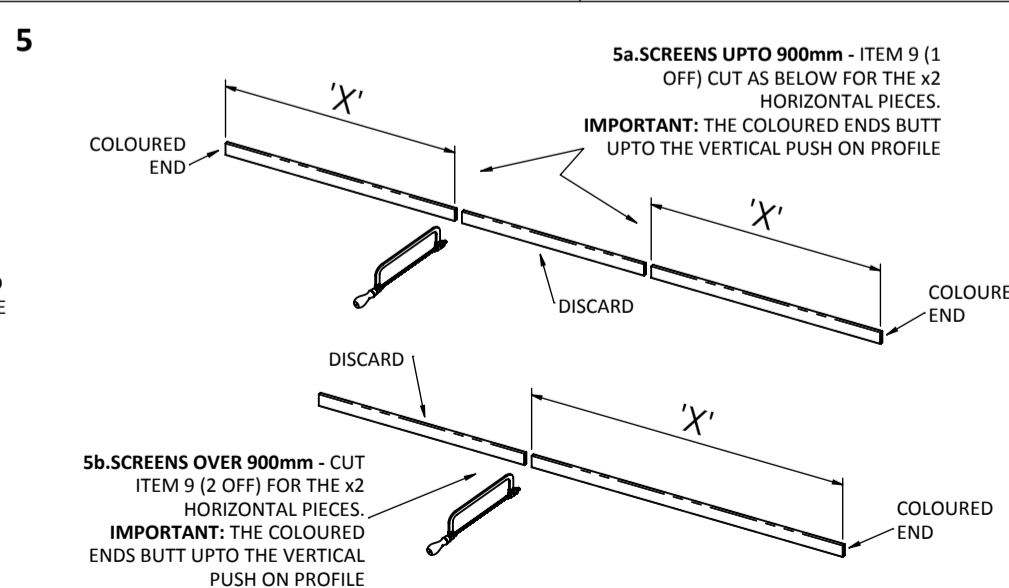
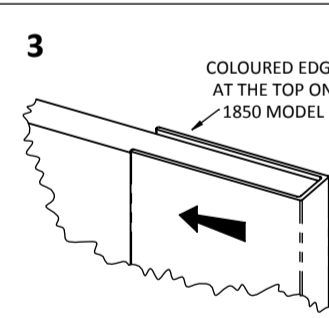
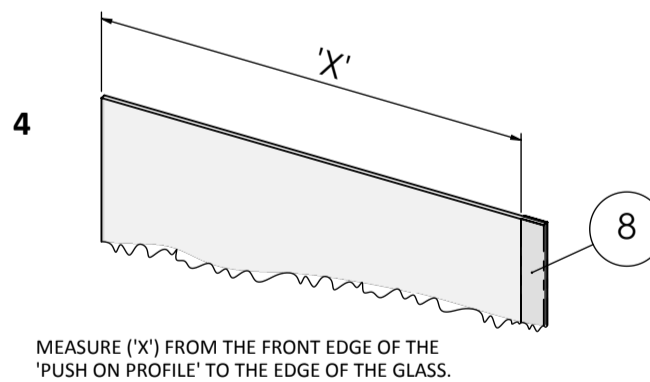
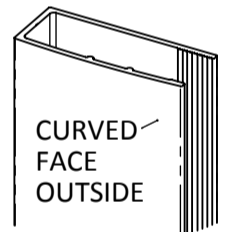
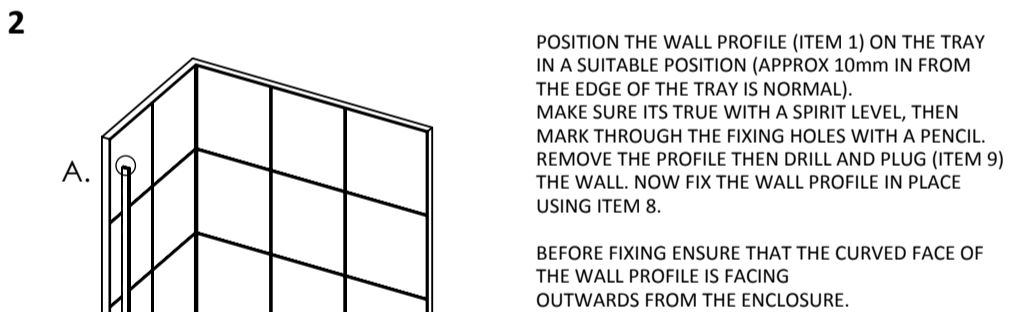
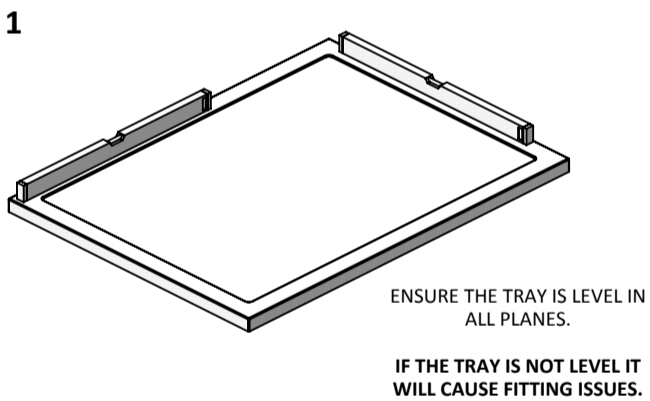
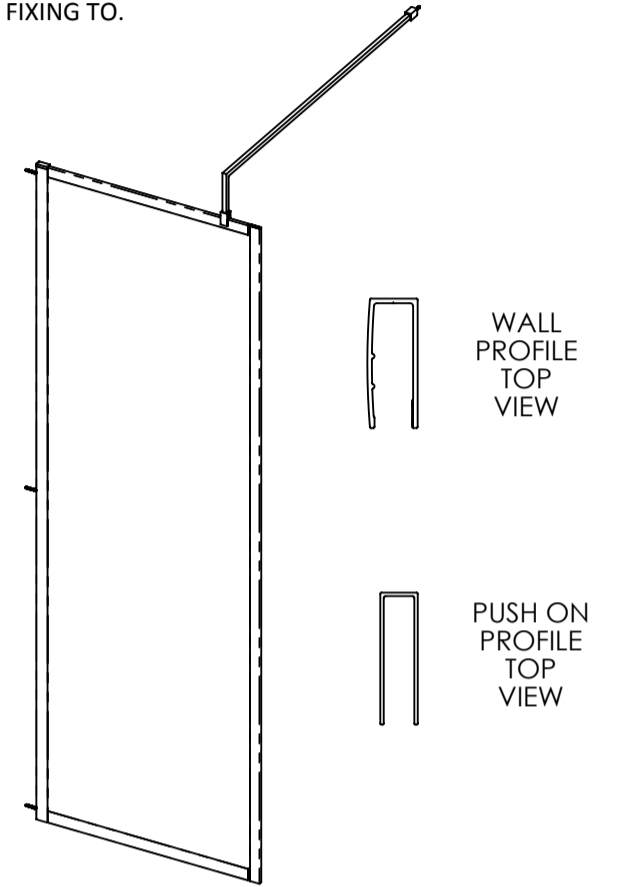

**5d. BOTTOM PROFILE IMPORTANT:** RUN A SMALL BEAD OF SILICONE IN THE BOTTOM PROFILE ON THE INSIDE FACE THAT WILL BE ON THE INSIDE OF THE SCREEN. PUSH THE PROFILE ONTO THE GLASS (COLOURED END BUTTED UPTO THE VERTICAL PROFILE) AND WIPE OFF ANY EXCESS SILICONE.

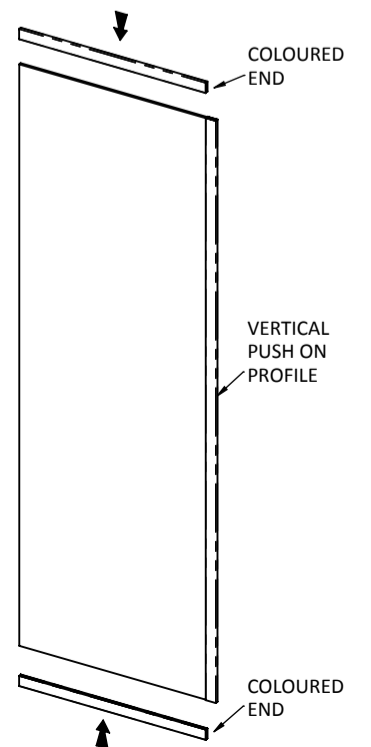

6

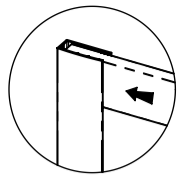
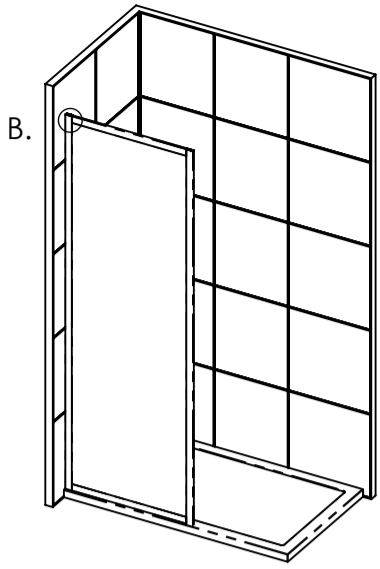

DETAIL B.  
SCALE 1 : 5

CAREFULLY SLIDE THE WETROOM SCREEN INTO THE WALL PROFILE TO AVOID ANY SCRATCHES ON THE HORIZONTAL PROFILES. ADJUST AS REQUIRED. (FULLY HOME PREFERABLY)

7

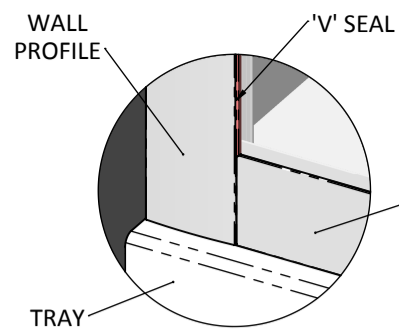
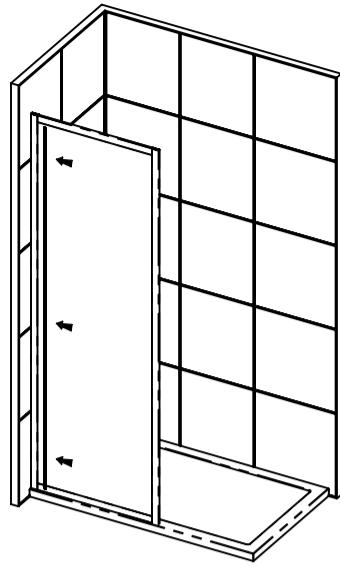

WALL PROFILE

'V' SEAL

BOTTOM PUSH ON PROFILE

TRAY

NOW FIT THE 'V' SEAL (ITEM 3) ON THE OUTSIDE OF THE SCREEN BETWEEN THE GLASS AND THE OUTER LEG OF THE WALL PROFILE. (THE V SEAL RUNS VERTICALLY BETWEEN THE TOP AND BOTTOM PUSH ON PROFILES).

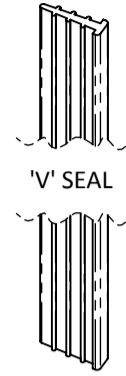

'V' SEAL

'V' SEAL

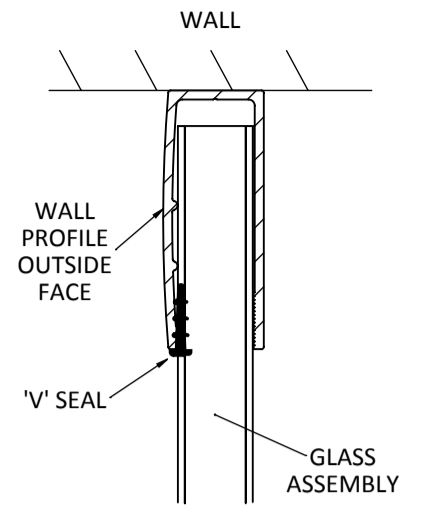

8

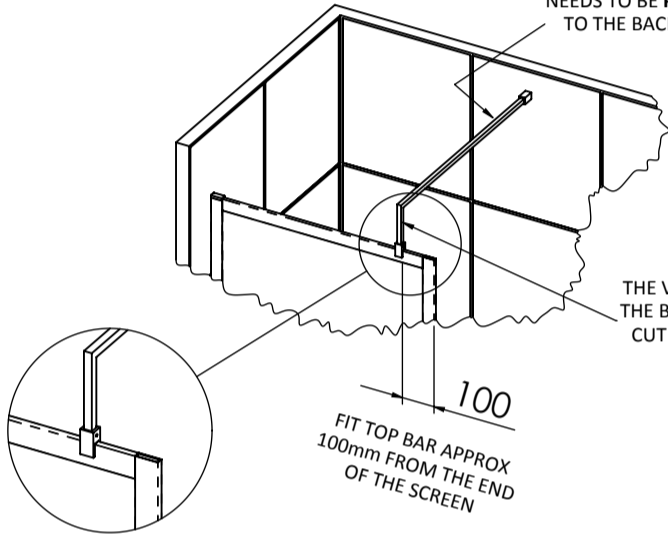

CUT THE LENGTH OF THE TOP BAR (ITEM 4) TO SUIT. THE SCREEN NEEDS TO BE **PARALLEL** TO THE BACK WALL

THE VERTICAL LEG OF THE BAR CAN ALSO BE CUT TO REDUCE ITS HEIGHT

100  
FIT TOP BAR APPROX 100mm FROM THE END OF THE SCREEN

9

ALLOW THE SILICONE AT LEAST 24 HOURS TO FULLY CURE.

**AFTERCARE** - ENSURE YOU CLEAN YOUR PRODUCT USING A MILD DETERGENT DILUTED IN WATER, REMOVING ANY RESIDUE WITH A SOFT DAMP CLOTH.

**MAINTENANCE** - ENSURE PARTS ARE FREE FROM ANY DEBRIS OR SOAP BUILD UP.

**TROUBLE SHOOTING GUIDE**

1. IS THE TRAY LEVEL (SEE STEP 1).
2. ARE THE WALL PROFILES PLUMB VERTICALLY (SEE STEP 2).
3. IS THE SCREEN PARALLEL TO THE ADJACENT WALL.

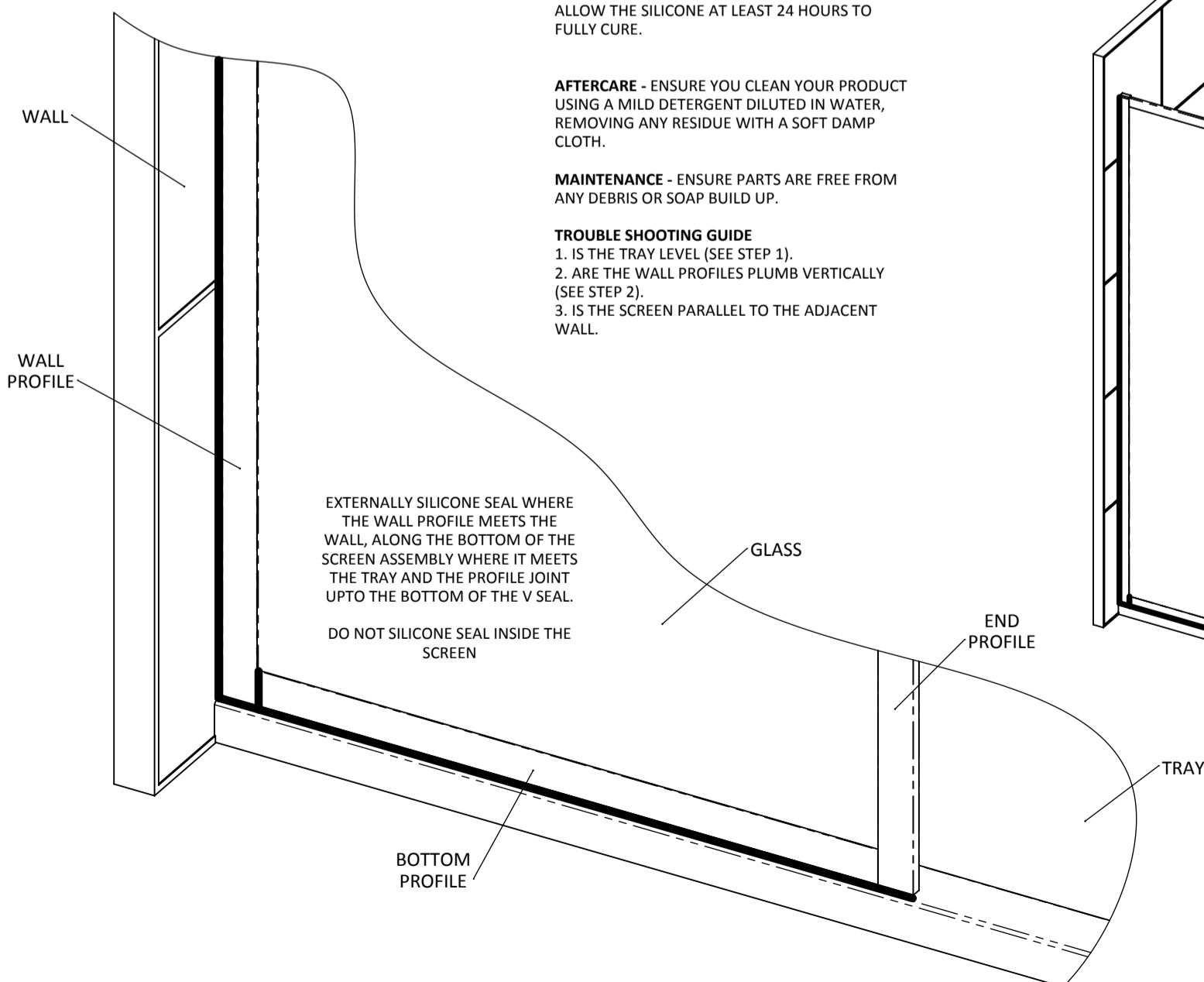

EXTERNALLY SILICONE SEAL WHERE THE WALL PROFILE MEETS THE WALL, ALONG THE BOTTOM OF THE SCREEN ASSEMBLY WHERE IT MEETS THE TRAY AND THE PROFILE JOINT UP TO THE BOTTOM OF THE V SEAL.

DO NOT SILICONE SEAL INSIDE THE SCREEN

