

# HERITAGE

## BATHROOMS

### *Installation Guide*



Models Covered:

#### **Bath Clicker Wastes**

**THA22**  
**THBB22**  
**THBL22**  
**THBN22**  
**THC22**

Please keep this booklet for future reference.

Installer: When you have read these instructions, please ensure you leave them with the user.

# INSTALLATION

## Components:

Identify all components are present prior to installation.

- |                        |      |
|------------------------|------|
| 1. Waste Body          | (x1) |
| 2. Rubber Washer       | (x1) |
| 3. Silicone Washer     | (x1) |
| 4. Flange              | (x1) |
| 5. Clicker Mechanism   | (x1) |
| 6. Button              | (x1) |
| 7. 500mm Overflow Tube | (x1) |
| 8. O-Rings             | (x1) |
| 9. Overflow Elbow      | (x1) |
| 10. Rubber Washer      | (x1) |
| 11. Grooved Washer     | (x2) |
| 12. Overflow Face      | (x1) |

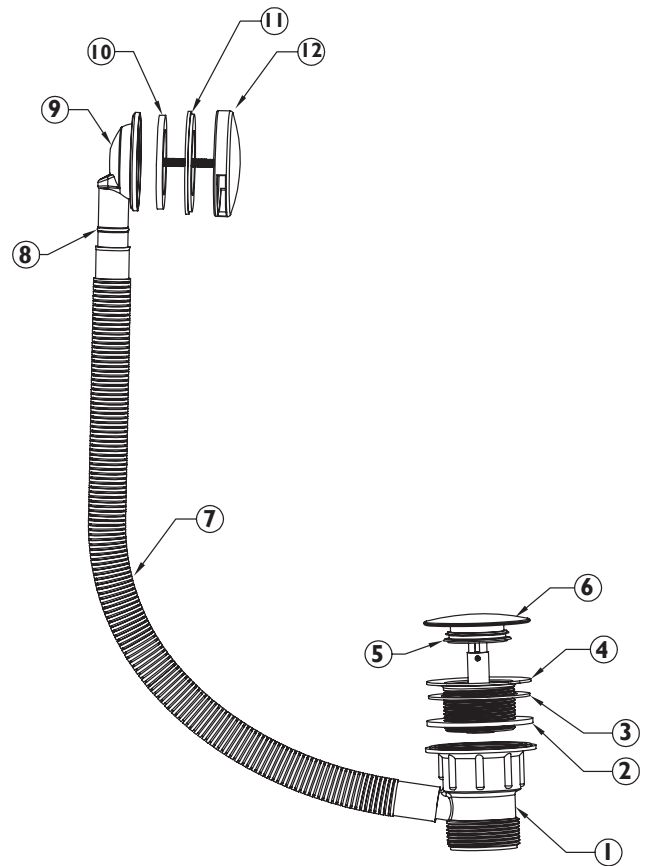

1. Place the waste body (1) and rubber washer (2) under the bath. Secure in place by screwing the flange (4) down from the top of the bath, ensuring the silicone washer (3) is underneath it.
2. Push the clicker mechanism (5) into the flange (4). Test that it works correctly by pushing on the button (6) to close, and pushing again for it to pop-up.
3. Place the overflow elbow (9) and rubber washer (10) to the back to the bath. Secure in place by screwing in the overflow face (12), ensuring the grooved washer (11) is in place.
4. The overflow tube (7) uses push-fit connections to secure in place. Push one end on to the overflow elbow (9), ensuring it goes over the two O-Rings (8). Squeeze the other end into the waste body (1), pushing in as far as possible.
5. Turn on the water supply and check all joints and connections for leaks.



---

## CARING FOR YOUR PRODUCT

---

Heritage products are made from premium materials, with hand polishing, PVD, EPD and electroplated finishes.

Your product should be regularly cleaned with warm water, a mild pH-neutral liquid soap, and polished with a soft cloth. Any residues from soap, toiletries etc. should be rinsed off straight after use.

Household bleaches and cleaners contain harsh chemicals and may damage the surface finish. Avoid using abrasive cloths, scouring pads, scrub sponges, steel wool or anything similar.

Some surfaces such as nickel and pewter may be affected by the dye found in some cloths, so it is also important to avoid leaving cloths on surfaces.

---

## GUARANTEE

---

The confidence we have in the quality of our products and services enables us to offer a free peace-of-mind product guarantee from 2 years up to a lifetime guarantee against any manufacturing faults, with proof of purchase. In addition, our attentive customer service team are available to help solve any problems which may arise quickly and effectively so you can enjoy your bathroom.

To see the specific guarantee for this product, scan the QR Code or visit the following URL:

<https://www.heritagebathrooms.com/service-centre/guarantee>

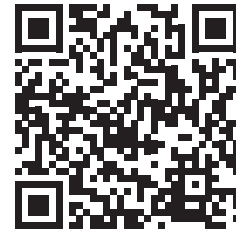

---

## NEED HELP?

---

In the unlikely event that you encounter a problem with your Heritage product, you must, in the first instance, contact the retailer you purchased it from. They will advise as to whether it is due to a manufacturing fault or an installation fault. If the problem is due to a manufacturing fault, they will contact us to arrange a supply of a replacement product as soon as possible. To speak to a Heritage customer service advisor, please contact our technical helpline on 0330 026 8503.



# HERITAGE<sup>®</sup>

## BATHROOMS

We love to see how Heritage products are used so please keep in touch and share pictures of your new bathroom with us.



@heritagebathrooms

If you have any queries, our dedicated customer service teams and products experts are available to help.

Email us [enquire@heritagebathrooms.com](mailto:enquire@heritagebathrooms.com) Call us **0330 026 8503** Website [www.heritagebathrooms.com](http://www.heritagebathrooms.com)

UK: Heritage Bathrooms, Pooley Hall Drive, Birch Coppice Business Park, Dordon, Tamworth B78 1SG

EU: Masco Europe S.à.r.l., 14 Rue Strachen, 6933 Mensdorf, Luxembourg.