

HERITAGE

BATHROOMS

Installation Instructions and User Guide

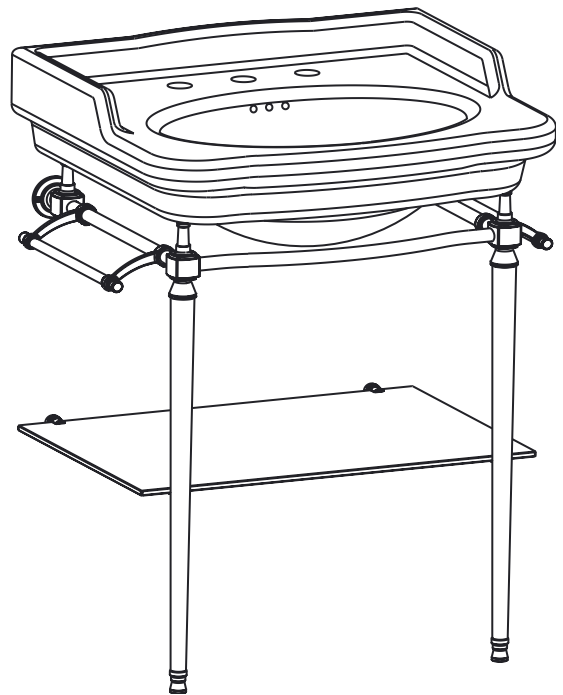

Abingdon Models Covered:

Blenheim Washstand (WSABBLE)
Dorchester Washstand (WSABDOR)
Victoria Washstand (WSABVIC)
Wynwood Washstand (WSABWYN)

Please keep this booklet for future
reference.

Installer: When you have read these
instructions please ensure you leave them
with the user.



Contents

When you purchase a Heritage product, you can be confident that it not only features a beautiful, distinctive, classical design, but also, that it has been made to the very highest quality standards.

To ensure that it works to its full potential, it needs to be fitted correctly.

These fitting instructions have been created to give you all of the information you need and if you need any further help, please do not hesitate to give us a call on 0844 701 8503.

Safety Information	03
Parts Supplied	04
Dimensions	05
Installation	06-08
Aftercare & Accessories	09
Guarantee	10-11

Important Safety Information

Warning: Before starting any installation please consider the following: Prior to drilling into walls or floors, check that there are no hidden electrical wires, cables or water supply pipes. This can be checked with the aid of an electronic detector.

If power tools are used do not forget to:

- Wear eye protection
- Unplug equipment after use

If you are unsure at all regarding the installation of this product, you should consult a competent person with experience of installing products of this nature.

The accuracy and levelness of these product greatly depends on the floor and walls being level and perpendicular to each other, if not then a spirit level can be used during the installation of the glass shelf to ensure a level surface.



Parts Supplied

Note: Please check this parts list and ensure you have all the parts before installing this product.

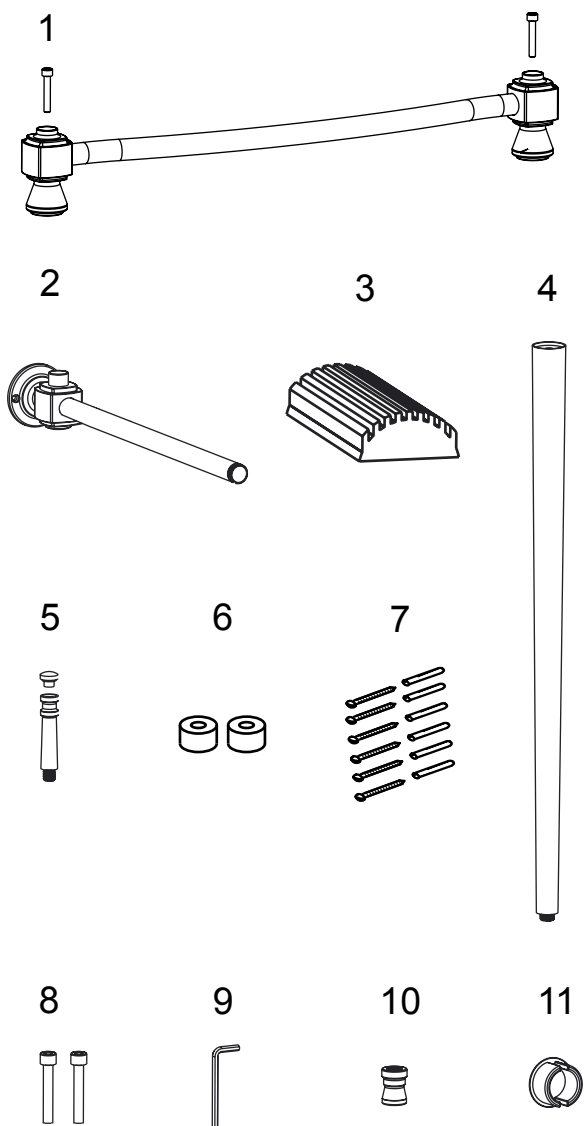

Item.	Description & Quantity
1	Front Pole Assembly x1
2	Pole Return Assembly x2
3	Inserts (Supplied with Wynwood and Victoria) x2
4	Leg Assembly x2
5	Chrome Columns and Basin Rests x4
6	Foot Stop x2
7	Chrome Plated Screws and Wall Plugs x6
8	M6 35mm Hex-Head Bolts x2
9	5mm Hexagonal Key x1
10	Washstand Foot x2
11	Blanking Plugs x6

Available accessories

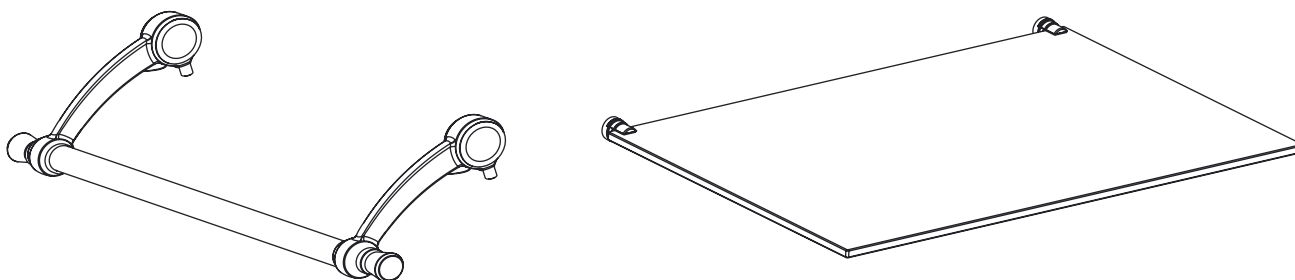

For a parts list for the towel rail or glass shelf units, please refer to the fitting instructions which come with those products.

Dimensions

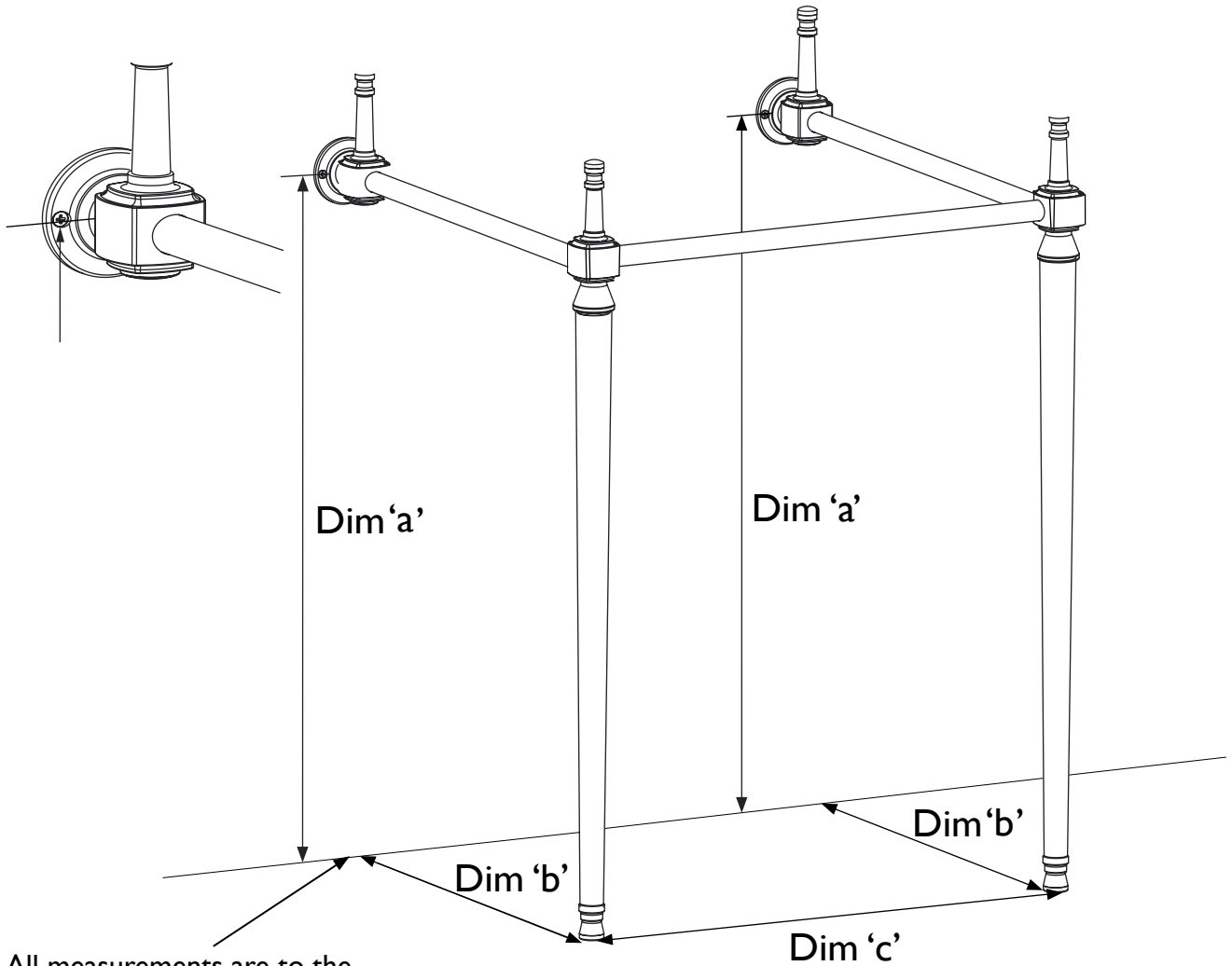

All measurements are to the centre of the legs, Dimension 'b' is measured to the wall and not the skirting board.

	Dim 'a'	Dim 'b'	Dim 'c'
Blenheim Dimensions	675mm	380mm	526mm
Dorchester Dimensions	675mm	445mm	575mm
Victoria Dimensions	675mm	445mm	500mm
Wynwood Dimensions	675mm	390mm	497mm



Installation

1

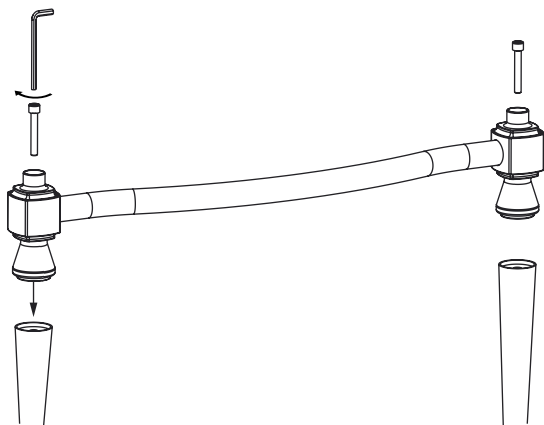

Attach both leg assemblies to the bottom of the front pole assemblies by using the M6 (35mm) hex bolt to secure the parts together.

2

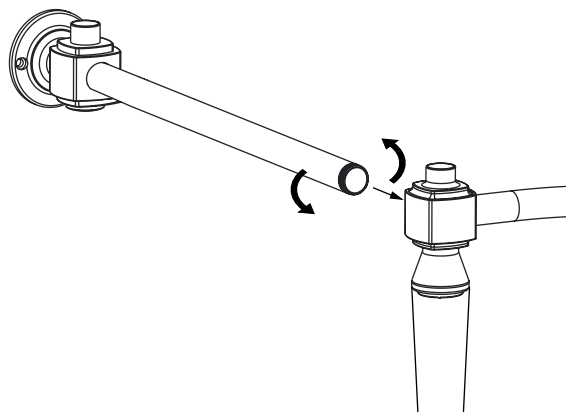

Towel Rail needs to be fitted at this stage if applicable. See instructions that come with that product.

Attach the front pole assembly to both pole return assemblies by screwing in the thread on the pole return assemblies into the front pole assembly (as above).

3

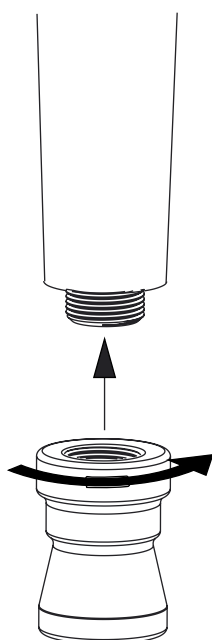

Attach the washstand feet to the base of the leg assemblies.

4

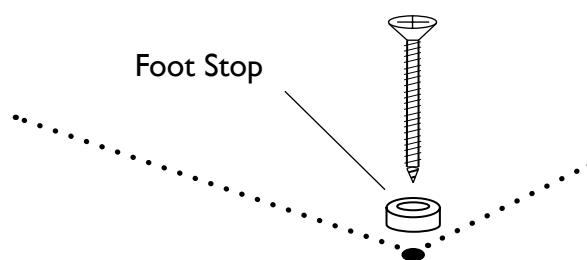

Using the dimensions (b & c) based on your washstand (page 5), accurately measure, mark and drill the holes in the floor for the foot stops and secure them down using the screws and suitable fixings for floor type.

Note: The measurement for the feet is critical to fitting the glass shelf correctly.

Installation

5

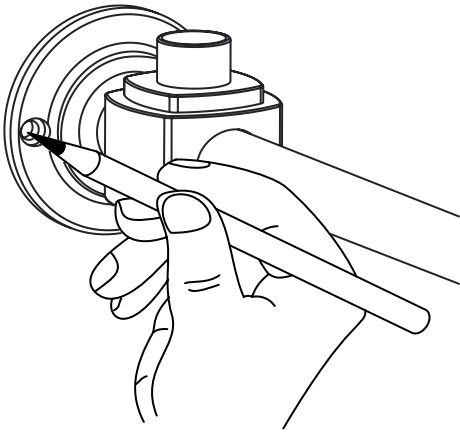

Locate the washstand on the newly installed Foot Stops and mark the location for the holes in the wall by using the washstand holes as the template. Ensure the washstand is level using a spirit level. Move the wash stand out of the way and Drill suitable holes.

6

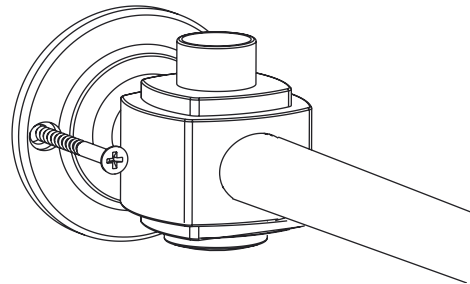

Secure the wash stand to the wall using suitable screws and wall plugs, depending on the wall type.

7

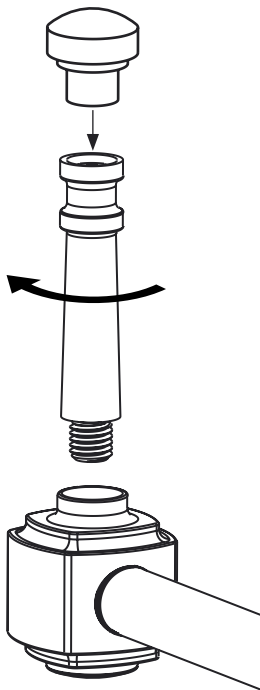

With the washstand in the correct position, add the chrome columns to the stand. Add the Basin Rests to the top of the chrome columns.

8

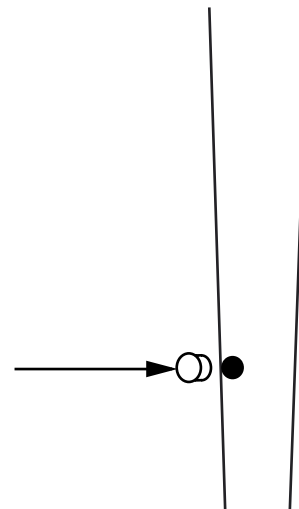

If the glass shelf is not going to be installed then use the 6 blanking plugs to cover the holes on the washstand.



Installation

9

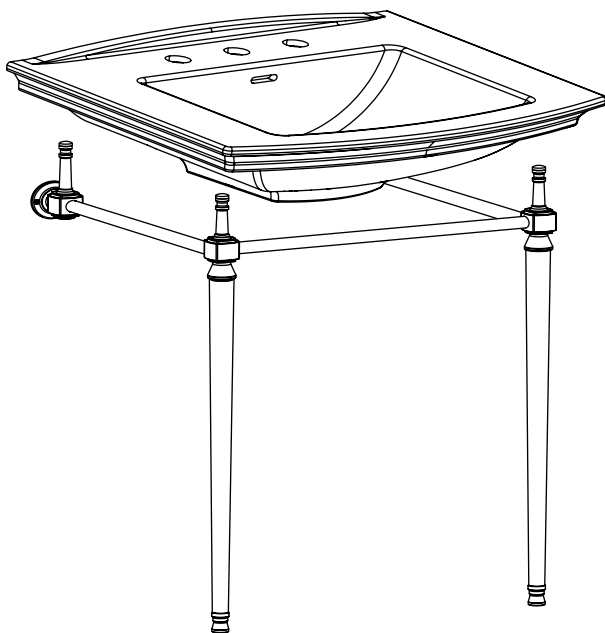

Locate the basin on the four chrome columns. If the product is supplied with inserts as seen in section 10, bear in mind that these need to be installed before levelling the basin.

10

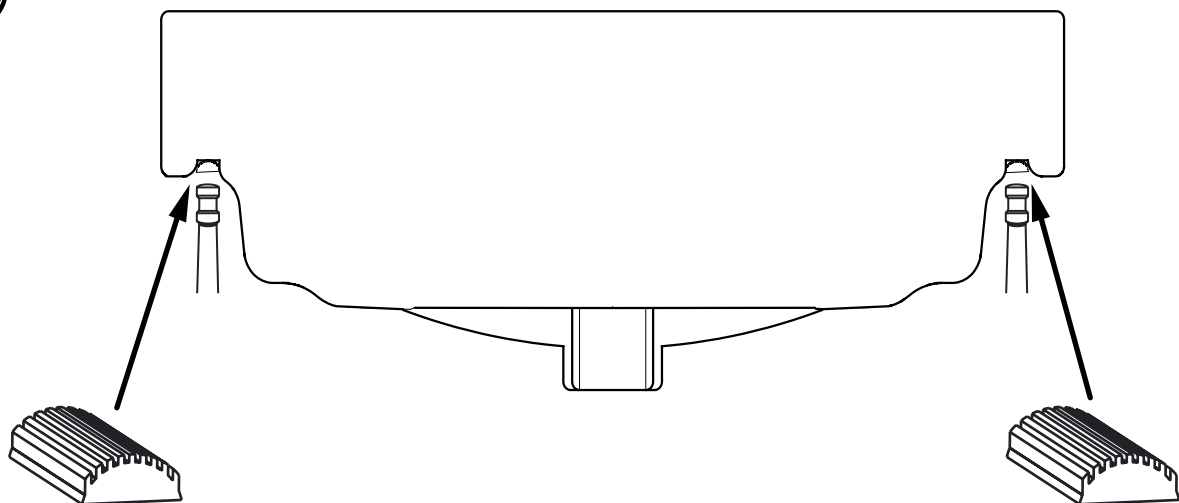

Fitting the inserts only applies to the Wynwood and Victoria models. Lift the sides of the basin up and slide the inserts into position. Using the chrome columns make sure the basin is level with the aid of a spirit level. The basin should be fitted to the wall using screws or a bolt hole fixing kit. Holes are located on the rear and installed from the underneath. Mark and drill the required holes once you have levelled the basin. **For installing shelf refer to instructions that come with that product.**

Aftercare

Your Heritage Bathroom Washstand has a high quality finish and should be treated with care to preserve the visible surfaces. All surface finishes will wear if not cleaned correctly. The only safe way to clean your accessory is to wipe with a soft damp cloth. Stains can be removed using washing up liquid. All bath cleaning products will damage the surface of your product, even non-scratch cleaners.

Accessories

To accompany your new Washstand, there is a few extras which can be purchased.

Abingdon Glass Shelf which attaches underneath the Washstand.

Please pay attention to the code which matches your Washstand Model Number:-

Washstand Code	Washstand Description	Accessory Code	Accessory Description
WSABBLE	Blenheim Washstand	WGABBLE	Blenheim Glass Shelf
WSABDOR	Dorchester Washstand	WGABDOR	Dorchester Glass Shelf
WSABVIC	Victoria Washstand	WGABVIC	Victoria Glass Shelf
WSABWYN	Wynwood Washstand	WGABWYN	Wynwood Glass Shelf

There is also a Towel Rail which attaches to the side of the basin. This fits to all Washstands.

Towel Rail Code	Towel Rail Description
WTABUNI	Abingdon Washstand Towel Rail Chrome



Heritage Bathrooms Guarantee

When you buy a Heritage product, you can be confident that it not only features distinctive design, but that it has also been made to meet our rigorous quality standards.

We offer robust guarantees and an attentive aftercare service to ensure that if you do experience any issues, we can deal with a problem quickly, and effectively,

Please note that guarantees are only valid with proof of purchase,

Our guarantees are as follows:



2 Years on
Mirrors & WC
Seats



5 Years on
Bath Screens,
Furniture,
Shower Valves,
Taps, Wastes,
Washstands &
Accessories



Lifetime Guarantees on Acrylic & Cast Iron Baths and Sanitaryware

Register now for additional peace of mind

Register your product with us now and, if you do have any queries after installation, we'll be able to quickly identify the product and give you the best advice. It also means that you won't have to keep your proof of purchase to validate your guarantee. To register, simply go on-line at www.heritagebathrooms.com/register

Guarantee Terms and Conditions

The guarantee is in addition to your statutory and other legal rights and is subject to the following conditions:

- The product was purchased within the United Kingdom or Republic of Ireland
- The product is used in domestic applications only
- The guarantee applies solely to the original purchaser with proof of purchase
- The installation must allow ready access to all products for the purpose of inspection, maintenance or replacement
- Repair under this guarantee does not extend the original expiry date. The guarantee on any replacement parts or product ends at the original expiry date

Any parts found to be defective during the guarantee period will be replaced without charge, providing that the product has been installed in accordance with the instructions given in this guide and used as the manufacturer intended. If the product is no longer available, Heritage will endeavour to provide the nearest equivalent.

Heritage Bathrooms Guarantee

The guarantee does not cover:

- Damage or defects caused by
 - General wear and tear (including special non-chrome finishes; components such as filters, seals, o-rings and washers)
 - Incorrect installation
 - Repair using non-Heritage parts
 - Accidental or wilful misuse
 - Corrosion and the use of inappropriate cleaning products
 - System debris including the build-up of limescale (which can be controlled through regular servicing and maintenance)
- Compensation for loss of use of the product or consequential loss of any kind

In the interests of continuous product improvement, Heritage reserves the right to alter product specifications without notice.

Need help?

In the unlikely event that you encounter a problem with your Heritage product, you must, in the first instance contact the retailer you purchased it from. They will advise as to whether it is due to a manufacturing fault or an installation fault. If the problem is due to a manufacturing fault, they will contact us to arrange a supply of a replacement product as soon as possible. To speak to a Heritage customer service advisor, please contact our technical helpline on **0844 701 8503**.



HERITAGE®
BATHROOMS

Heritage Bathrooms
Birch Coppice Business Park
Dordon
Tamworth
B78 1SG

Website: www.heritagebathrooms.com

Telephone: 0844 701 8503

Email: technical@heritagebathrooms.com

Abingdon Washstands - DI

