

# HERITAGE

## BATHROOMS

### *Installation Guide*



Abingdon Washstand Models Covered:

Blenheim (WSABBLE)  
Claverton (WSABCLA)  
Dorchester (WSABDOR)  
Victoria (WSABVIC)  
Wynwood (WSABWYN)  
Wynwood 800 (WSABWYN8)

Please keep this booklet for future  
Reference.

Installer: when you have read these  
instructions please ensure you leave them  
with the user.

---

## Introduction



Thank you for buying a Heritage Product. When you buy a Heritage product, you can be confident that it not only features a beautiful, distinctive, classic design, but that it has also been made to the very highest quality standards.

To ensure that it works to its full potential, it needs to be fitted correctly.

These fitting instructions have been created to give you all of the information you need and, if you need any further help, please do not hesitate to give us a call on 0330 026 8503.

---

## Contents



Safety Notice	03
Contents	04
Dimensions	05
Installation	06-08
Caring for your product	09
Guarantee	10-11

---

## Safety Notice

---

Please read these instructions and retain for future use.

All products manufactured and supplied by Heritage are safe, provided they are installed correctly, used correctly, and receive regular maintenance in accordance with these instructions.

If you are in any doubt about your ability to install this product safely you must employ the services of an competent person who has experience of fitting products of this nature.

⚠ Before starting any installation project please consider the following:

- Prior to drilling into walls, check there are no hidden electrical wires or cables or water supply pipes with the aid of an electrical detector.
- If you use power tools do not forget:
  - Wear eye protection.
  - Unplug equipment after use.
- This product must not be modified in any way as this will invalidate the guarantee.

# Contents

**Note:** Please check this parts list and ensure you have all the parts before installing this product.

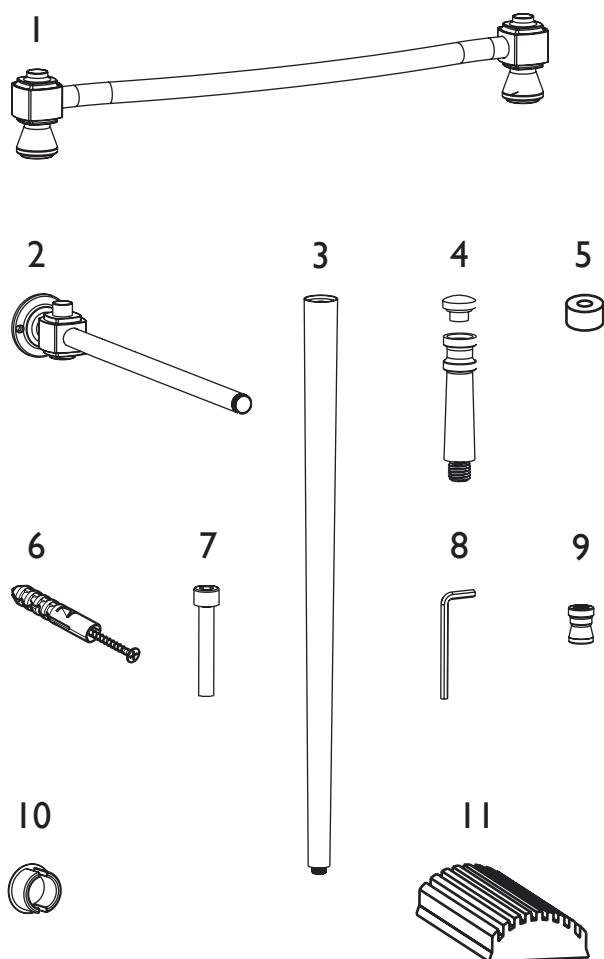

Item	Description	Qty
1	Front Pole Assembly	1
2	Pole Return Assembly	2
3	Leg Assembly	2
4	Chrome Columns and Basin Rests	4
5	Foot Stop	2
6	Chrome Plated Screws and Wall Plugs	6
7	M6X25mm Hex-head Bolts	2
8	5mm Hexagonal Key	1
9	Washstand Foot	2
10	Blanking Plugs	6
11	Inserts (Supplied only with Wynwood and Victoria)	2

## Available Accessories

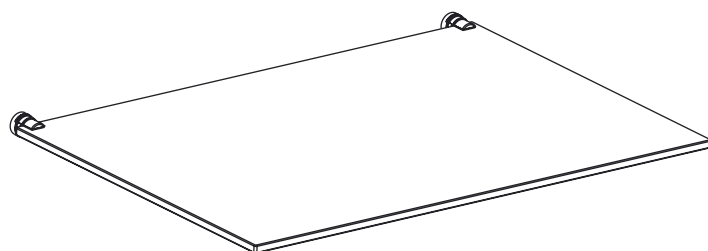
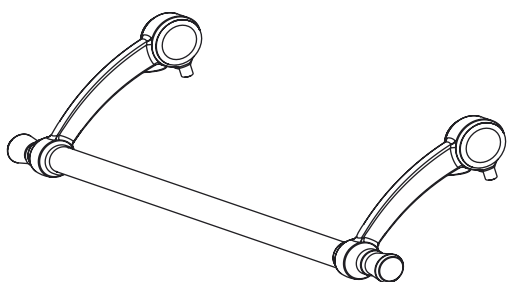

For a parts list for the towel rail or glass shelf, please refer to the separate fitting instructions that accompany them products

# Dimensions

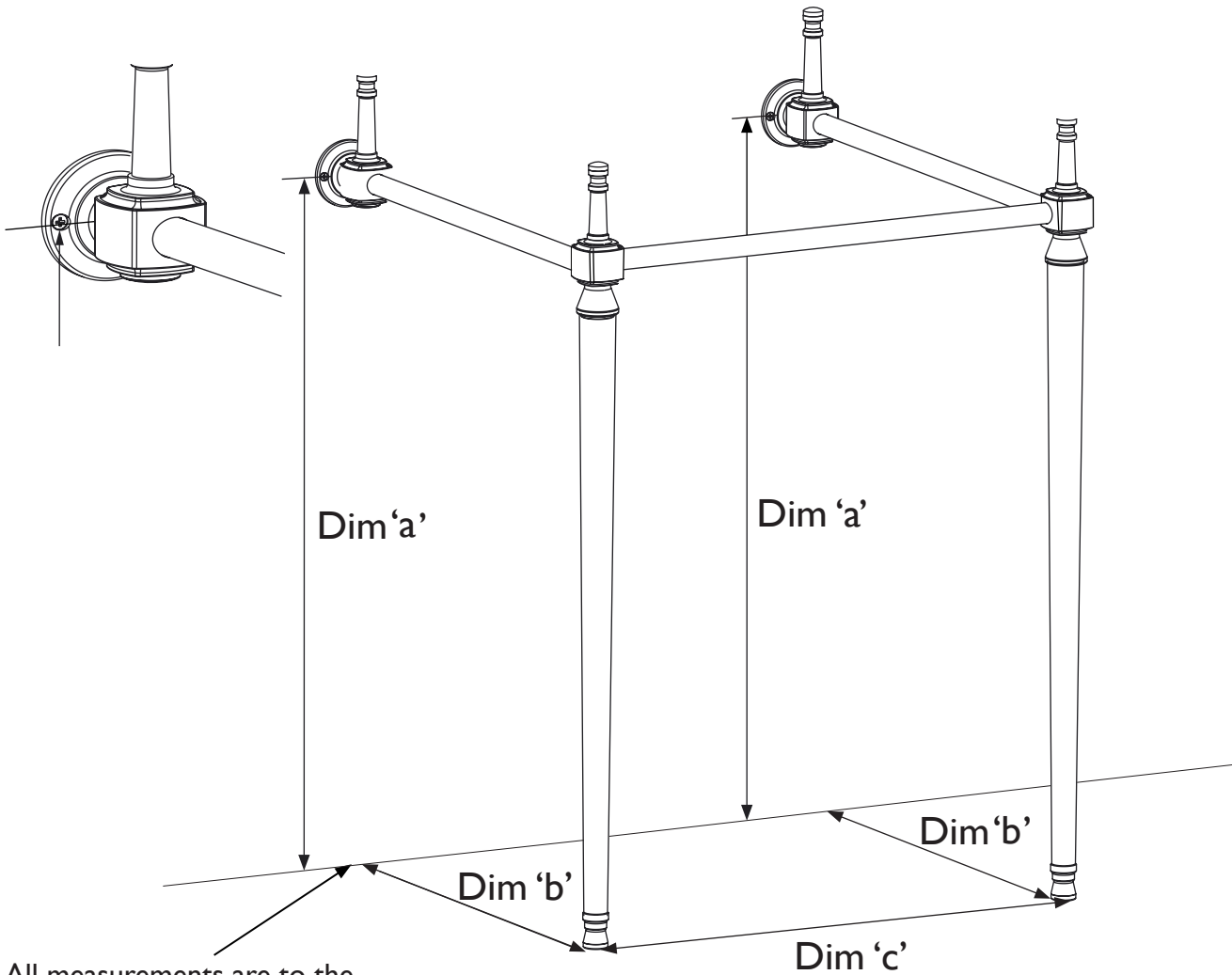

All measurements are to the centre of the legs, Dimension 'b' is measured to the wall and not the skirting board.

	Dim 'a'	Dim 'b'	Dim 'c'
Blenheim Dimensions	675mm	380mm	526mm
Dorchester Dimensions	675mm	445mm	575mm
Victoria Dimensions	675mm	445mm	500mm
Wynwood Dimensions	675mm	390mm	497mm
Wynwood 800 Dimensions	675mm	390mm	730mm
Claverton Dimensions	675mm	275mm	600mm

# Installation

1

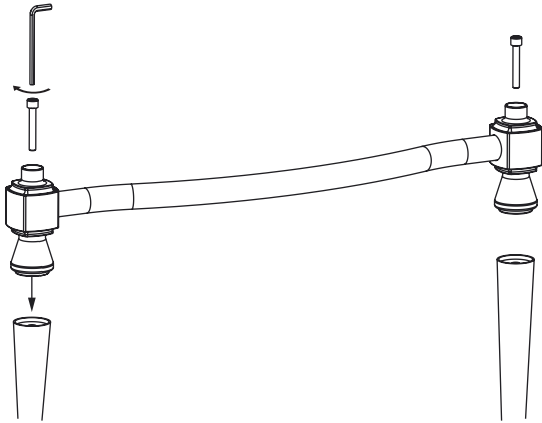

Attach both leg assemblies to the bottom of the front pole assemblies by using the M6 (35mm) hex bolt to secure the parts together.

2

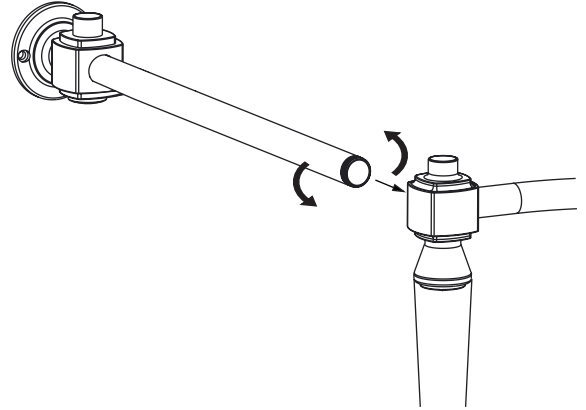

**Towel Rail needs to be fitted at this stage if applicable. See instructions that come with that product.**

Attach the front pole assembly to both pole return assemblies by screwing in the thread on the pole return assemblies into the front pole assembly (as above).

3

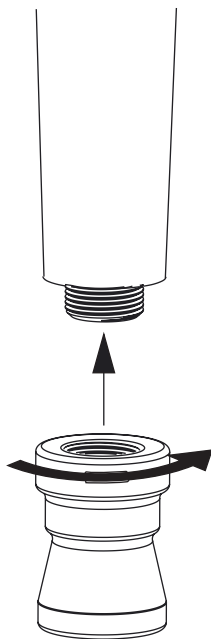

Attach the washstand feet to the base of the leg assemblies.

4

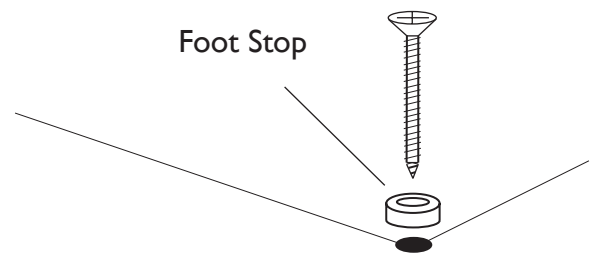

Using the dimensions (b & c) based on your washstand (page 5), accurately measure, mark and drill the holes in the floor for the foot stops and secure them down using the screws and suitable fixings for floor type.

**Note:** The measurement for the feet is critical to fitting the glass shelf correctly.

# Installation



5

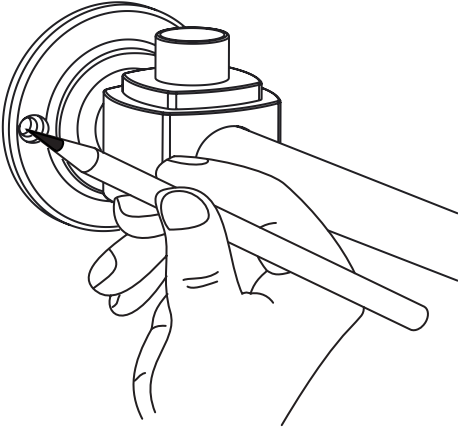

Locate the washstand on the newly installed Foot Stops and mark the location for the holes in the wall by using the washstand holes as the template. Ensure the washstand is level using a spirit level. Move the wash stand out of the way and Drill suitable holes.

6

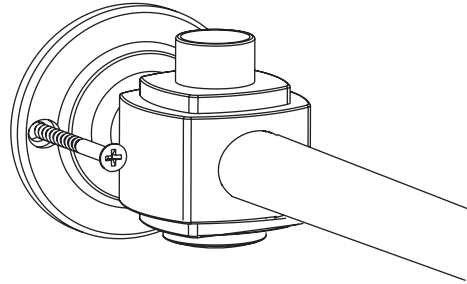

Secure the wash stand to the wall using suitable screws and wall plugs, depending on the wall type.

7

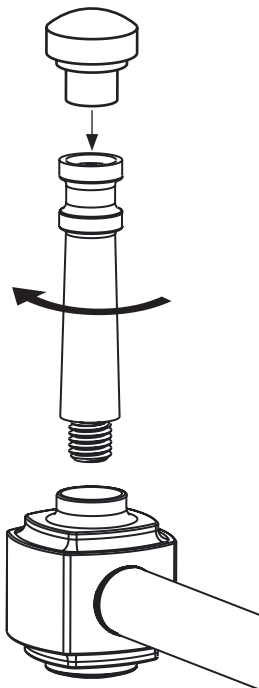

With the washstand in the correct position, add the chrome columns to the stand. Add the Basin Rests to the top of the chrome columns.

8

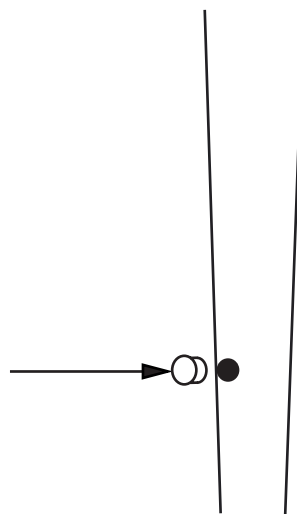

If the glass shelf is not going to be installed then use the 6 blanking plugs to cover the holes on the washstand.

## Installation

9

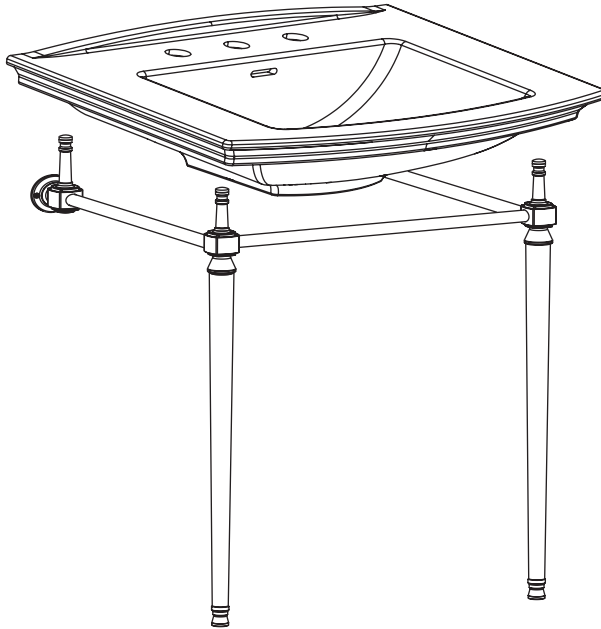

Locate the basin on the four chrome columns. If the product is supplied with inserts as seen in section 10, bear in mind that these need to be installed before levelling the basin.

10

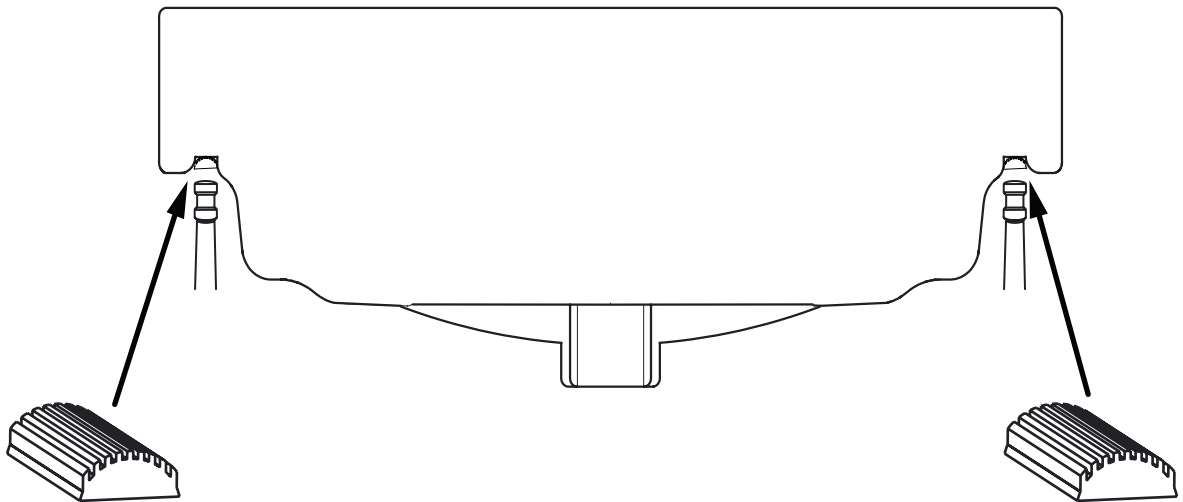

**Fitting the inserts only applies to the Wynwood and Victoria models.** Lift the sides of the basin up and slide the inserts into position. Using the chrome columns make sure the basin is level with the aid of a spirit level. The basin should be fitted to the wall using screws or a bolt hole fixing kit. Holes are located on the rear and installed from the underneath. Mark and drill the required holes once you have levelled the basin. **For installing shelf refer to instructions that come with that product.**



---

## Caring for your product

---

Your fitting has a high quality finish and should be treated with care to preserve the visible surface.

A few tips for preventing defects from forming:

Occasionally wipe the surface with a soft damp cloth and dry with a soft dry cloth.

Do not use any abrasive cleaning agents or materials, these will change the surface condition from the standard finish.

---

## Accessories

---

To accompany your new Washstand, there is a few extras which can be purchased.

Abingdon Glass Shelf which attaches underneath the Washstand.

Please pay attention to the code which matches your Washstand Code:-

Washstand Code	Washstand Description	Accessory Code	Accessory Description
<b>WSABBLE</b>	Blenheim Washstand	<b>WGABBLE</b>	Blenheim Glass Shelf
<b>WSABDOR</b>	Dorchester Washstand	<b>WGABDOR</b>	Dorchester Glass Shelf
<b>WSABVIC</b>	Victoria Washstand	<b>WGABVIC</b>	Victoria Glass Shelf
<b>WSABWYN</b>	Wynwood Washstand	<b>WGABWYN</b>	Wynwood Glass Shelf
<b>WSABCLA</b>	Claverton Washstand	<b>WGABCLA</b>	Claverton Glass Shelf
<b>WSABWYN8</b>	Wynwood Washstand 800mm	<b>WGABWYN8</b>	Wynwood Glass Shelf 800mm

There is also a Towel Rail which attaches to the side of the basin. This fits to all Washstands except the Claverton..

Towel Rail Code	Towel Rail Description
<b>WTABUNI</b>	Abingdon Washstand Towel Rail Chrome

---

## Heritage Bathrooms Guarantee

---

When you buy a Heritage product, you can be confident that it not only features distinctive design, but that it has also been made to meet our rigorous quality standards.

We offer robust guarantees and an attentive aftercare service to ensure that if you do experience any issues, we can deal with a problem quickly, and effectively.

Please note that guarantees are only valid with proof of purchase.

Our guarantees are as follows:



---

## Register now for additional peace of mind

---

Register your product with us now and, if you do have any queries after installation, we'll be able to quickly identify the product and give you the best advice. It also means that you won't have to keep your proof of purchase to validate your guarantee. To register, simply go online at [www.heritagebathrooms.com/register](http://www.heritagebathrooms.com/register)

---

## Guarantee Terms and Conditions

---

This guarantee is in addition to your statutory and other legal rights and is subject to the following conditions:

The product was purchased within the United Kingdom or Republic of Ireland

The product is used in domestic applications only

The guarantee applies solely to the original purchaser with proof of purchase

The installation must allow ready access to all products for the purpose of inspection, maintenance or replacement

Repair under this guarantee does not extend the original expiry date. The guarantee on any replacement parts or product ends at the original expiry date

Any part found to be defective during the guarantee period will be replaced without charge, providing that the product has been installed in accordance with the instructions given in this guide and used as the manufacturer

---

## Heritage Bathrooms Guarantee



---

The guarantee does not cover:

- Damage or defects caused by
  - General wear and tear (including special non-chrome finishes; components such as filters, seals, 'O' rings and washers)
  - Incorrect installation
  - Repair using non-Heritage parts
  - Accidental or wilful misuse
  - Corrosion and the use of inappropriate cleaning products.
  - System debris including the build-up of limescale (which can be controlled through regular servicing and maintenance)
- Compensation for loss of use of the product or consequential loss of any kind.

In the interests of continuous product improvement, Heritage reserves the right to alter product specifications

---

## Need help?



---

In the unlikely event that you encounter a problem with your Heritage product, you must, in the first instance, contact the retailer you purchased it from. They will advise as to whether it is due to a manufacturing fault or an installation fault. If the problem is due to a manufacturing fault, they will contact us to arrange a supply of a replacement product as soon as possible. To speak to a Heritage customer service advisor, please contact our technical helpline on **0330 026 8503**.



# HERITAGE<sup>®</sup>

## BATHROOMS

---

### *Contact Details*

---

Heritage Bathrooms  
Birch Coppice Business Park  
Dordon  
Tamworth  
B78 1SG

Website: [www.heritagebathrooms.com](http://www.heritagebathrooms.com)  
Customer Services Telephone: 0330 026 8503  
Email: [technical@heritagebathrooms.com](mailto:technical@heritagebathrooms.com)

Abingdon Washstands - D2