

2. Attach the Securing Clip to the riser rail and slide it over the Collet until it is tightly fixed in the desired position on the rail.

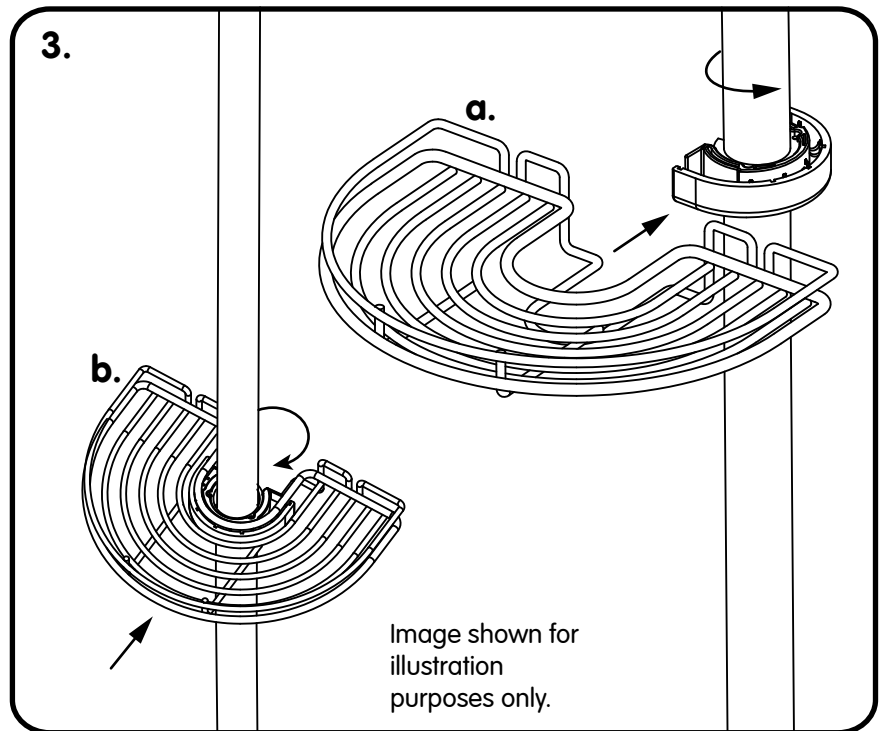

3. Place the basket over the Securing Clip. It may be necessary to rotate the Securing Clip through 90 degrees to allow the clip to pass through the back of the wire basket.

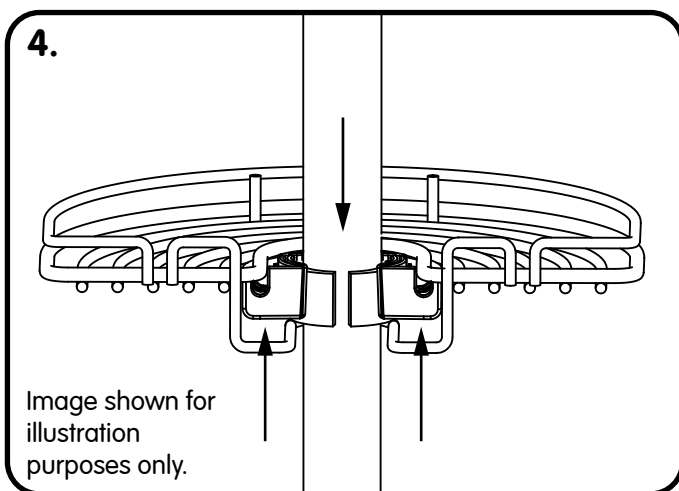

4. Align the 'D' shape wire profile of the basket with the 'D' shape recess in the Securing Clip and press the two components together until they click into place.

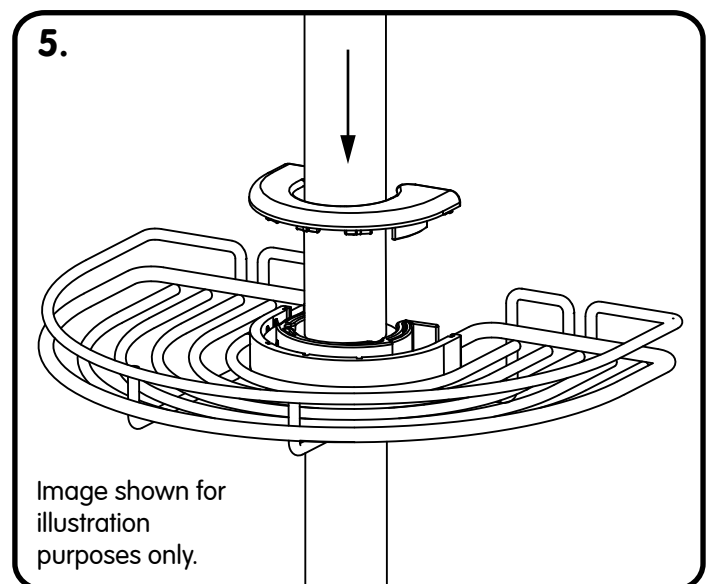

5. Finally, align the Cover Plate with the Securing Clip and press together to finish the assembly.