

# MM703000E BATTERY OPERATED MIRROR

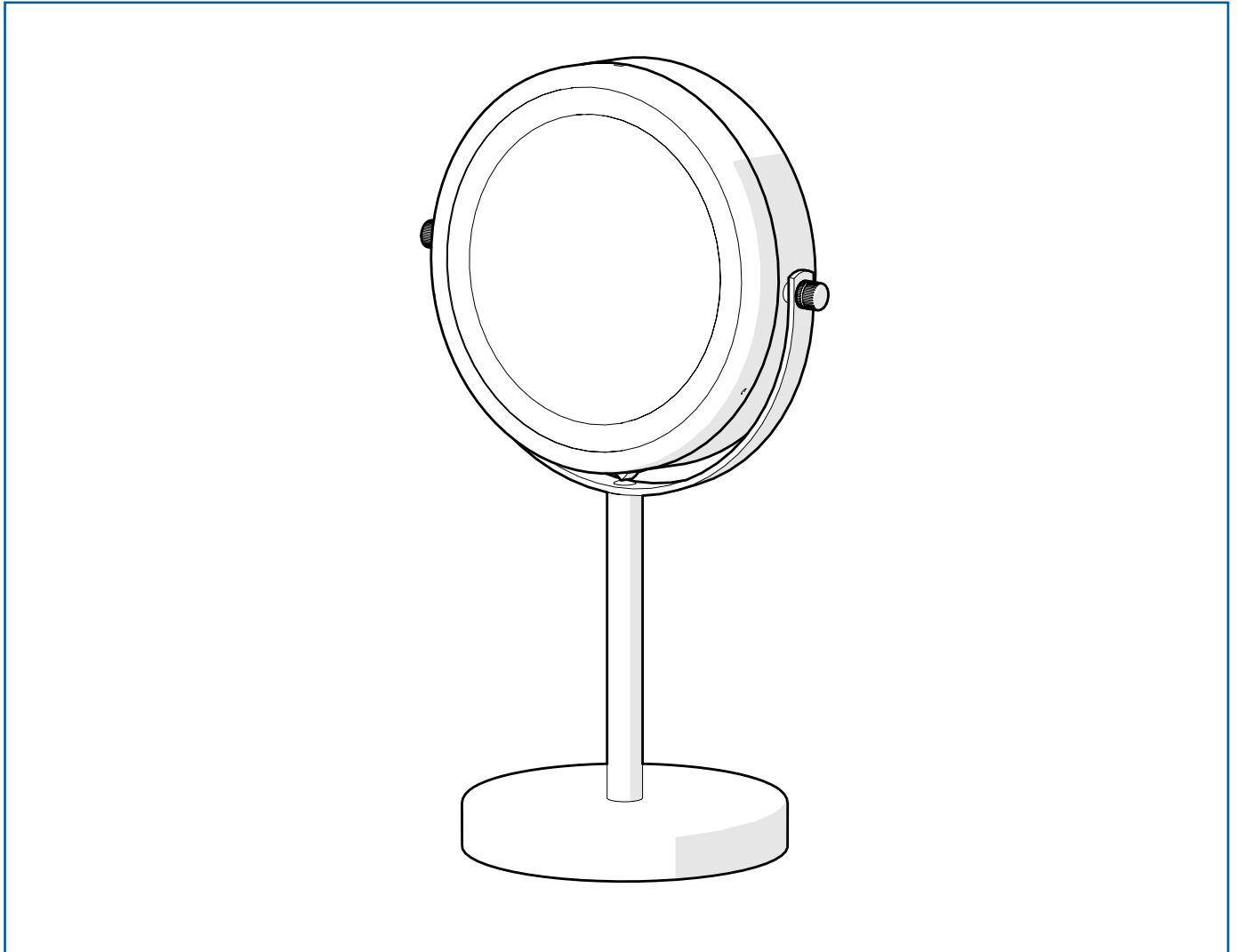

## CONTACT DETAILS

Croydex  
Central Way  
Andover  
Hampshire  
SP10 5AW  
UK

Tel: +44 (0)1264 365881  
Email: [info@croydex.co.uk](mailto:info@croydex.co.uk)

[www.croydex.com](http://www.croydex.com)

**ALL ILLUSTRATIONS OF THE PRODUCT ARE FOR  
REFERENCE ONLY. COMPONENTS SUPPLIED WITH  
INDIVIDUAL PRODUCTS MAY DIFFER.**

**THIS PRODUCT REQUIRED 4 X AAA BATTERIES.  
BATTERIES NOT PROVIDED**

# TABLE OF CONTENTS

<b>SECTION</b>	<b>CONTENTS</b>	<b>PAGE</b>
1	INTRODUCTION	3
2	PRE-INSTALLATION	3
3	PRODUCT ASSEMBLY	4
4	PRODUCT DIMENSIONS	5
5	DECLARATIONS OF CONFORMITY	6

# SECTION 1 INTRODUCTION

## INTRODUCTION

Please follow all assembly and product care instructions to ensure that your product is assembled safely and retains its high quality finish.

**PLEASE RETAIN THIS LEAFLET FOR FUTURE REFERENCE**

# SECTION 2 PRE-INSTALLATION

## PRODUCT FITTING

### IMPORTANT!

Before attempting to fit or use this product. Ensure that it can be properly installed in the location you wish it to be in. Refer to the product dimensions found in **SECTION 4**

## SAFETY & PRODUCT CARE

- 1. DO NOT** use abrasive or chemical cleaners as these may damage the product.
- 2. DO NOT** strike the product with hard or sharp objects.
- 3. ALWAYS** dispose of used batteries through recognised electrical equipment waste disposal schemes.
- 4. DO NOT** break open or burn used batteries. Incorrect disposal of spent batteries may be hazardous to health.

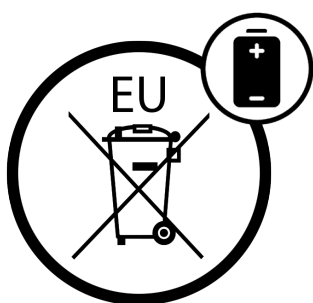

# SECTION 3 - PRODUCT ASSEMBLY

## INSTALLING BATTERIES

1. Rotate the front cover in the open direction according to the sticker on the product. Then remove the front cover. (See Fig. 1)

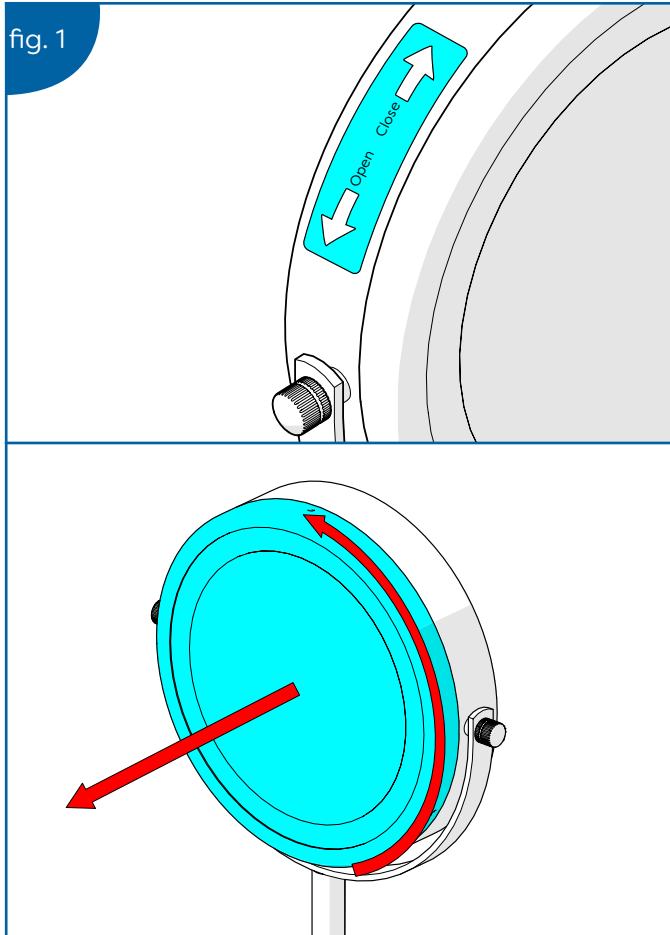

2. Remove the battery cover. (See Fig. 2)

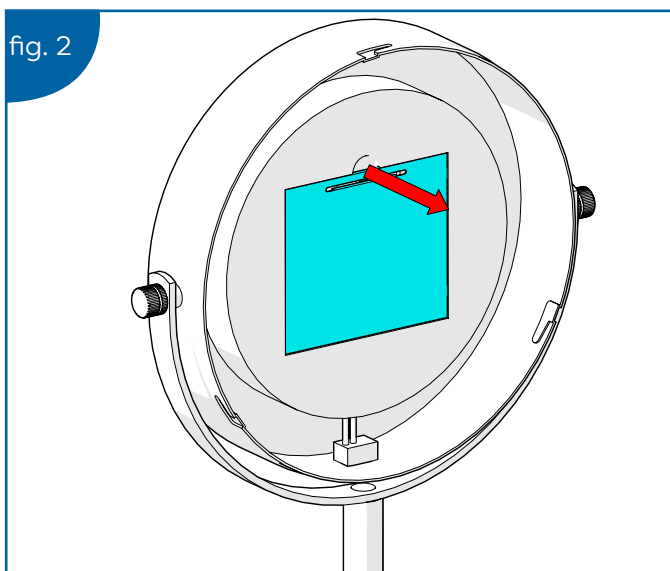

3. Insert 4 AAA batteries into the battery compartment.

**YOU MUST ENSURE THE BATTERIES ARE INSERTED IN THE CORRECT ORIENTATION!**

(See Fig. 3)

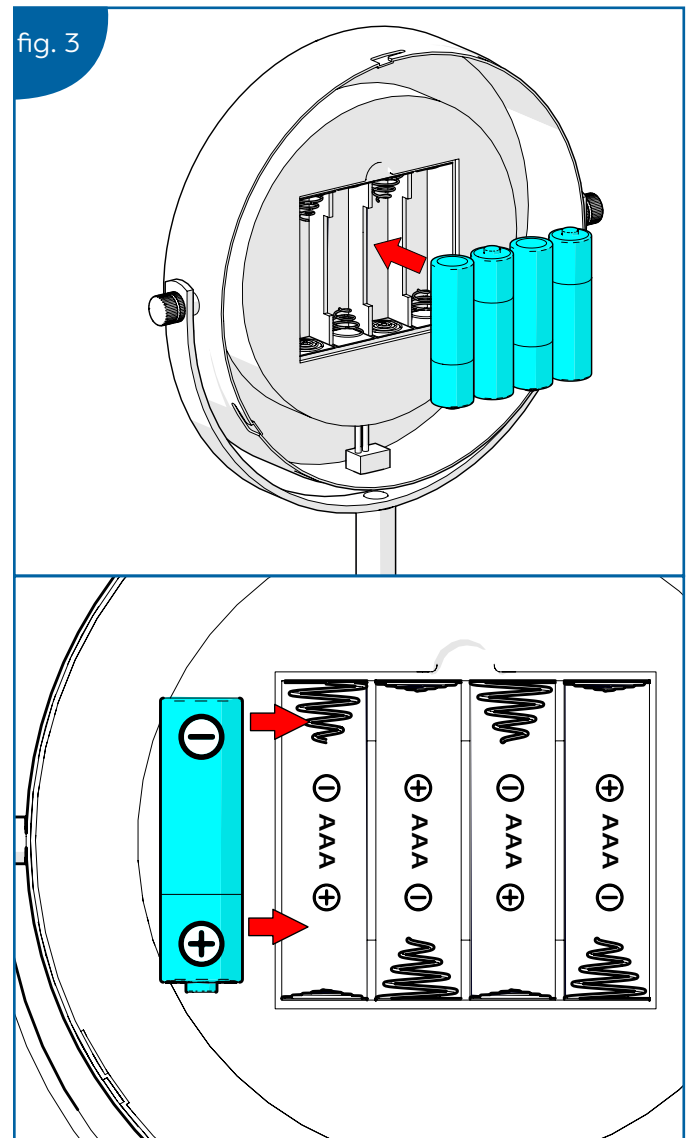

4. Reinstall the battery cover and the front cover.

**The mirror is now ready for use!**

## SECTION 4 - PRODUCT DIMENSIONS

All dimensions listed in this leaflet regarding the product and installation are approximate.

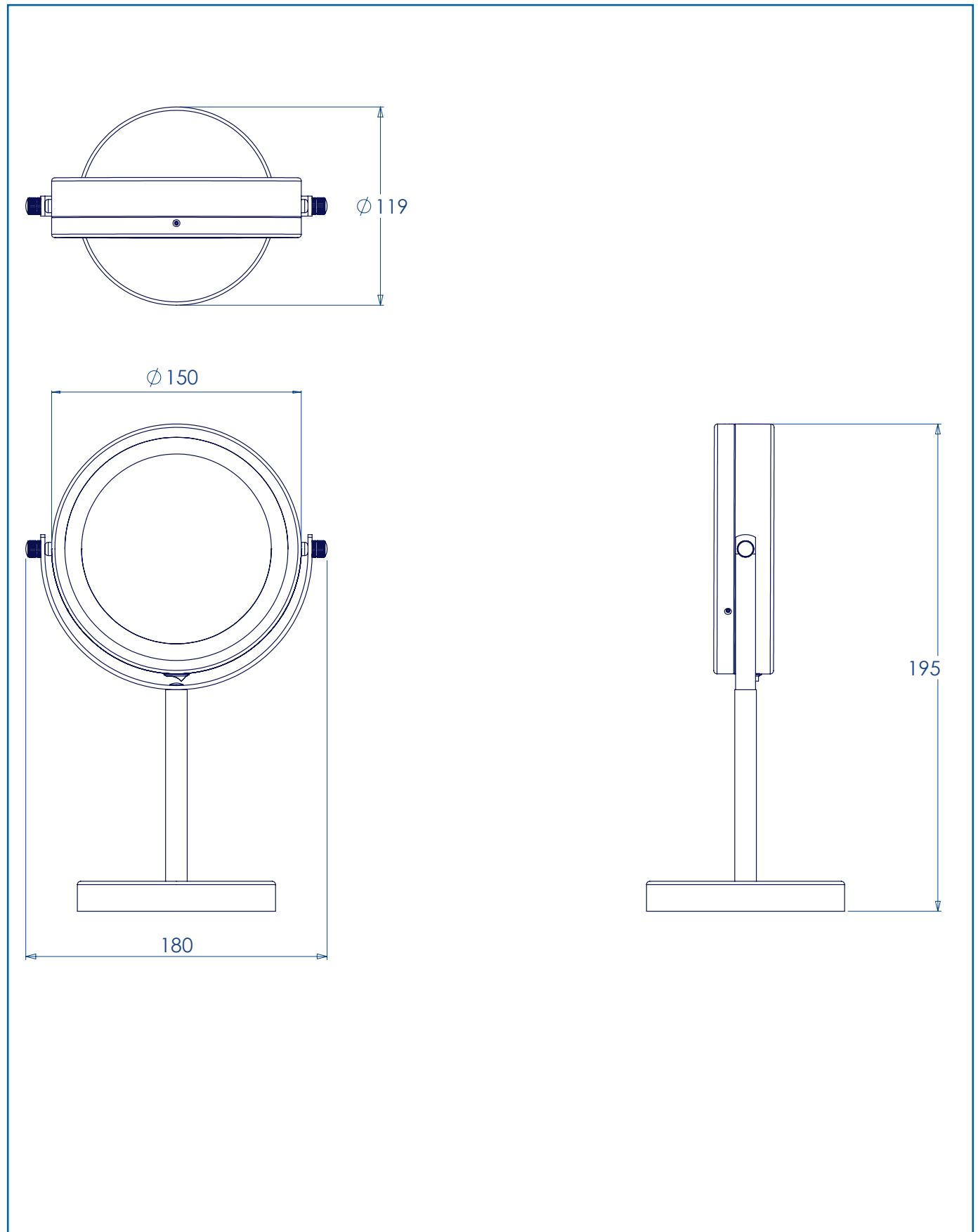



## To the Restriction of Hazardous Substances (RoHS) Directive 2011/65/EU as amended by Commission Delegated Directive (EU) 2015/863

### 1. Description of products:-

**MM703000E Free-Standing LED Illuminated Magnifying Mirror**

### 2. Directives complied with:-

European Council Directive 2011/65/EU of 8 June 2011 on the restriction of the use of certain hazardous substances in electrical and electronic equipment (recast).

### 3. Declaration

It is hereby certified that the concentration by weight of the restricted substances in the homogenous materials in the products described above at section 1 do not exceed the maximum allowed concentrations listed in European Council Directive 2011/65/EU Annex II Restricted substances referred to in Article 4(1) and maximum concentration values tolerated by weight in homogeneous materials, as detailed below:

Substance	Concentration
Lead	0.1%
Mercury	0.1%
Cadmium	0.01%
Hexavalent Chromium	0.1%
PBB (Polybrominated Biphenyls)	0.1%
PBDE ( Polybrominated Diphenyl Ethers)	0.1%
Bis(2-ethylhexyl) phthalate (DEHP)	0.1%
Butyl benzyl phthalate (BBP)	0.1%
Dibutyl phthalate (DBP)	0.1%
Diisobutyl phthalate (DIBP)	0.1%

For and on behalf of CROYDEX

P. Pegden  
Product and Procurement Director  
Date: 04-03-2020



# EU DECLARATION OF CONFORMITY



## To the Electromagnetic Compatibility (EMC) Directive 2014/30/EU

### 1. *Description of products:-*

**MM703000E Free-Standing LED Illuminated Magnifying Mirror**

### 2. *Directives complied with:-*

European Parliament/Council Directive 2014/30/EU on the harmonisation of the laws of the Member States relating to electromagnetic compatibility (EMC) Directive (recast).

### 3. *Declaration*

The products listed above in section 1 conform to the following harmonised standards:

#### **EMC**

BS EN 55015:2013

BS EN 61547:2009

For and on behalf of CROYDEX

P. Pegden  
Product and Procurement Director  
Date: 04-03-2020