

INSTALLATION

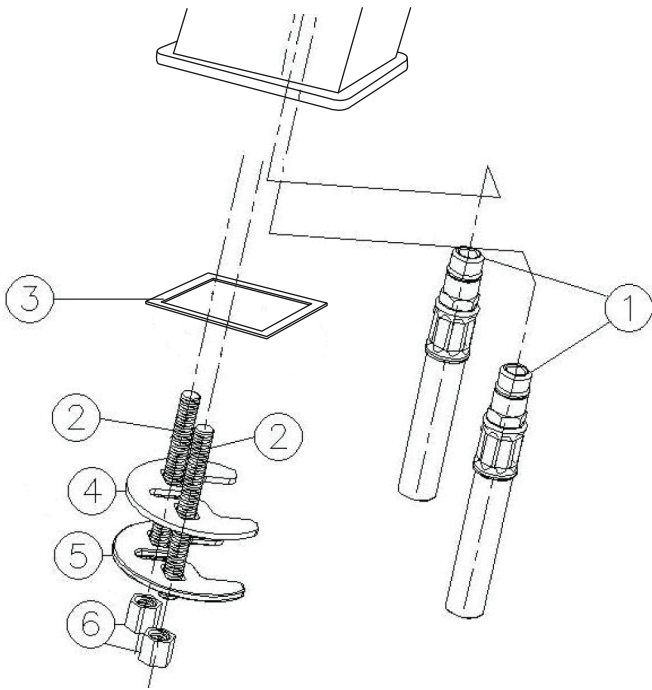

4

MAINTENANCE

WD112DNC

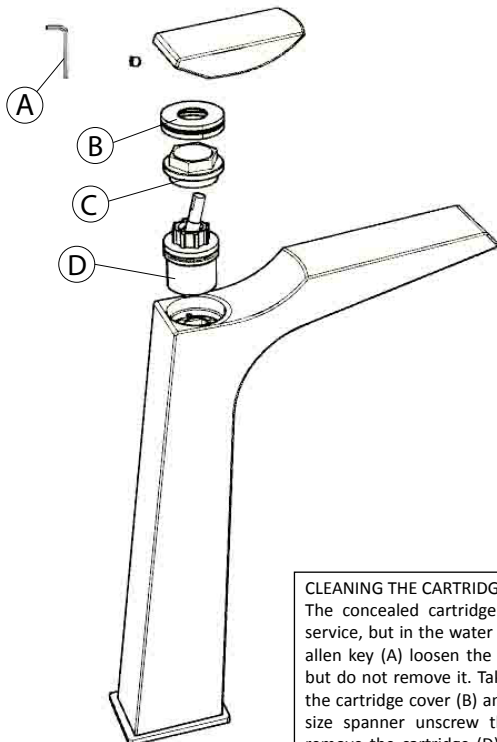

CLEANING THE CARTRIDGE

The concealed cartridge should give trouble free service, but in the water supply to the tap. With an allen key (A) loosen the grub screw in the handle, but do not remove it. Take off the handle, unscrew the cartridge cover (B) and carefully using a correct size spanner unscrew the retaining nut (C) and remove the cartridge (D). Wash the cartridge with clean running water and make sure that any trapped debris have been removed. Dry and lightly grease the seals (only use silicone grease) and replace the cartridge, retaining nut, cartridge cover followed by the handle.

6

INSTALLATION

First shut off your heating system then, with your mains stop cock closed, open the Lowest hot and cold taps in the house and allow to run until the cold storage tank and pipes are empty (the hot water storage cylinder airways remains full). Where combination boilers are fitted it is only necessary to turn off the boiler and shut off the incoming mains. Fitting isolating valves to the inlet feeds is recommended for ease of maintenance.



Remember to turn off the mains water supply before connecting to any existing pipe work. Flush the piping with plenty of water prior to installation.

- Firstly Verify that your basin is provided with a standard hole according to UNI EN 31 law (35mm +2/-1).
- Screw up the two flex tails (1) to the mixer body, taking care to tighten well.
- Screw the threaded screws (2) into the body mixer, insert the o'ring (3) under the base of the mixer.
- then, insert the mixer in the hole from above the basin, making the flex tails passing through first.
- Working below the basin, insert the specifically shaped rubber gasket (4) and the metallic insert (5) in the threaded screws (2).
- tighten the nuts (6) on the threaded fittings (2) having care to position correctly the mixer onto the basin.
- Connect the flex tails (1) at the filters (supplied) and to the water system.

5

crosswater^x

CLEANING

The chrome plate we use on our taps is very durable, nevertheless care should be taken when cleaning them. They should be cleaned only with warm soapy water followed by rinsing with clean water and drying with a soft cloth. All finishes are vulnerable to acid attack and some strong substances such as household cleaners, disinfectants, denture cleaners, hair dyes, wine making and photographic chemicals can cause the surface to go black or peel.

7



WARNING
 -Installation Performed By Qualified Personnel Only!
 -Clean Carefully the water Pipes Before Installing The Tap.
 These taps are double flow. Water bylaw require that where the hot water is supplied from a tank and cold from the mains, non return valves are fitted on both hot and cold pipes as dose as possible to he tap, These are not supplied. Where combination boilers are fitted it is only necessary to shut off the incoming mains and turn the boiler off and non return valves are not required.

Approvals
 All product are manufacture using materials tested and approved under the Water Bylaws Scheme and comply with requirements of British Standard 5412:1996 where applicable.
 Preparation and bylaw requirements
 These taps are double flow. Water bylaw require that where the hot water is supplied from a tank and cold from the mains, non return valves are fitted on both hot and cold pipes as dose as possible to he tap, These are not supplied. Where combination boilers are fitted it is only necessary to shut off the incoming mains and turn the boiler off and non return valves are not required.

Standard specifications
 1. Recommended working pressure:.....1 Bar
 2. Maximum test pressure:.....5 Bar
 3. Maximum hot water temperature:.....80° c
 4. We recommend istalling filters ti thus product.
 5. Warning:
 - if the above mentioned conditions (see pots 1,2,3,4) are not observed, the product may not correctly work or not work at all.
 - on receipt of this product the chrome finish must be checked for blemishes. Defects notified after fitting may be regarded as damage resulting from the installation process, incorrect maintenance or misuse and as a result not be claimable under the warranty.

General Installation Requirements
 The installation must comply with regulations of the Local Water Authority as continued in their bylaws. All of the taps in this range are double flow (the hot and cold water are separated) and should therefore be supplied with hot and cold water at balanced pressures, both from the tank or both from the mains (via a combination boiler for example). If the taps are not supplied at balanced pressures then the tap will not function correctly. It will also be necessary to fit non-return valves on both hot and cold feeds. It is very important that all pipe work is flushed thoroughly after installation to avoid damaging the ceramic disc.

INTRODUCTION

TALL WASHBASIN MIXER - NO POPUP WASTE

WD112DNC

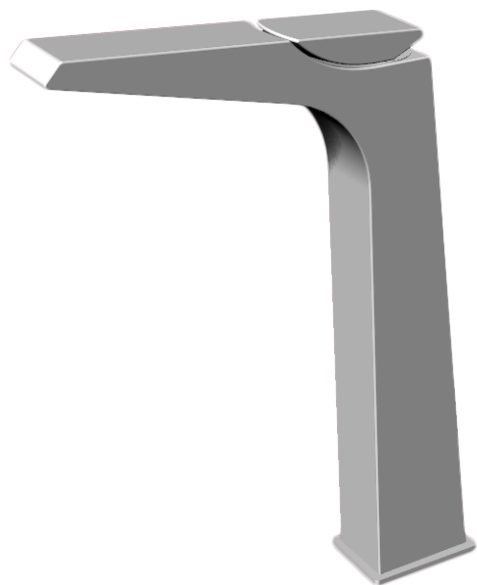

INSTALLATION INSTRUCTIONS

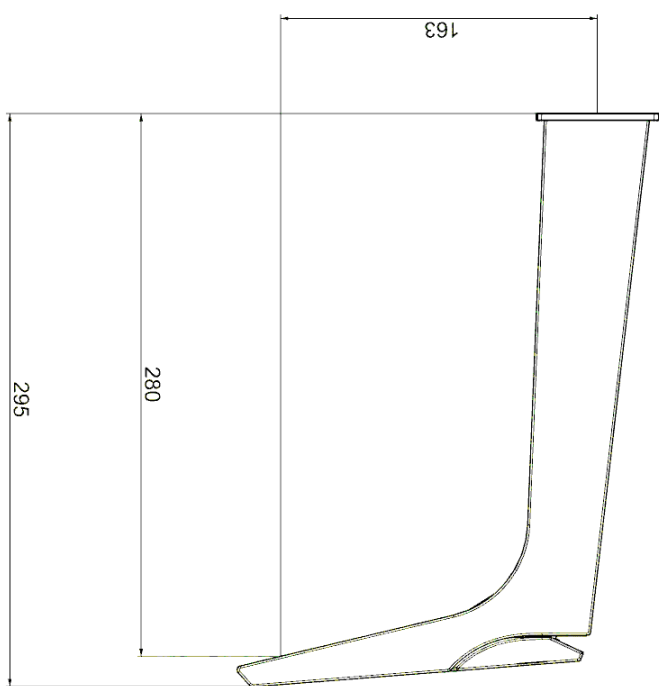

DIMENSIONS

WD112DNC

This product should only be fitted by a qualified plumber to NQV (National Vocational Qualification) or SNVQ (Scottish National Vocational Qualification) Level 3. Should the Installation be completed by a non-qualified person then the guarantee may be considered invalid.
 For a claim made under our warranty written certification of your installers credentials can be required. For further information or to find a qualified installer in your aerea please visit the Istitute of Plumbers website - www.iphe.org.uk.

THE QUALIFICATIONS

At present, to be a plumber you need to follow the National Vocational Qualification (NVQ) route (Scottish National Vocational Qualification-SNVQ-in Scotland). These qualifications are made uoof theory and pratical work in the classroom/purpose built training facility and work based experience with a working plumber. Colleges should help students find a work placement, although many students organize it themselves.
 The S7NVQ qualification works in levels. All recently qualifies plumbers should hold S7NVQ level 2 as basin with Level 3 as the preferred leve. Level 2 will give you the foudation you need for a career in plumbing and teach you domestic plumbing to a satisfactory leve,. Leve 3 is more comprehensive and deals with domestic, commercial and industrial plumbing along with aspects such as gas - if you want to one day set up your own business, this is the level to reach. The Istitute of Plumbing and Heating Engineering, and the industry as a whole recommand that all plumbers reach a minimum of Level 3.
 Reaching Level 3 has other advantages. The Institute runs a Master Plumber Certificate, which only those attaining Level 3 or equivalent can reach as long as they have the relevant experience as well. Those with S/NVQ Level 3 can (once in membership with the Istitute for five years as a member MIPHE) gain Engineering Technician EngTech status with the Engineering Council (UK).

For any further information please contact Crosswater on: **0845 873 8840**
 Or visit our web-site at www.crosswater.co.uk
 The manufacturer reserves the right to make technical modifications without prior notice