

This product should only be fitted by a qualified plumber to NVQ (National Vocational Qualification) or SNVQ (Scottish National Vocational Qualification) Level 3. Should the installation be completed by a non-qualified person then the guarantee may be considered invalid.

For a claim made under our warranty written certification of your installers credentials can be required. For further information or to find a qualified installer in your area please visit the Institute of Plumbers website - [www.iphe.org.uk](http://www.iphe.org.uk)

### THE QUALIFICATIONS

At present, to be a plumber you need to follow the National Vocational Qualification (NVQ) route (Scottish National Vocational Qualification - SNVQ - in Scotland). These qualifications are made up of theory and practical work in the classroom/purpose built training facility and work based experience with a working plumber. Colleges should help students find a work placement, although many students organise it themselves.

The S/NVQ qualification works in levels. All recently qualified plumbers should hold S/NVQ Level 2 as basic with Level 3 as the preferred level. Level 2 will give you the foundation you need for a career in plumbing and teach you domestic plumbing to a satisfactory level. Level 3 is more comprehensive and deals with domestic, commercial and industrial plumbing along with aspects such as gas - if you want to one day set up your own business, this is the level to reach. The Institute of Plumbing and Heating Engineering, and the industry as a whole recommends that all plumbers reach a minimum of Level 3.

Reaching Level 3 has other advantages. The Institute runs a Master Plumber Certificate, which only those attaining Level 3 or equivalent can reach as long as they have the relevant experience as well. Those with S/NVQ Level 3 can (once in membership with the Institute for five years as a Member MIPHE) gain Engineering Technician EngTech status with the Engineering Council (UK).

For any further information please contact  
C.P. HART on: **0845 600 1970**

Or visit our web-site at [www.cphart.co.uk](http://www.cphart.co.uk)

The manufacturer reserves the right to make technical modifications without prior notice.

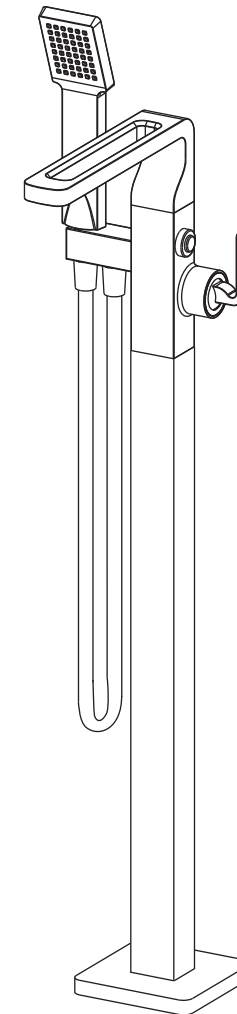

### INSTALLATION INSTRUCTIONS

## INTRODUCTION

Please read these instructions carefully and keep in a safe place for future reference.

**General Installation Requirements.**

The installation must comply with regulations of the Local Water Authority as contained in their bylaws. All of the taps in this range are single flow (the hot and cold water mix in the body) and should therefore be supplied with hot and cold water at balanced pressures, both from the tank or both from the mains (via a combination boiler for example). If the taps are not supplied at balanced pressures then the mixer will not function correctly. It will also be necessary to fit non-return valves on both hot and cold feeds. It is very important that all pipework is flushed thoroughly after installation to avoid damaging the ceramic discs.

**Minimum/Maximum working pressure**

These taps are suitable for high pressure installations. They are fitted with a half turn ceramic disc cartridge which provides a good flow rate with very smooth movement. The required minimum water pressure is 2 bar. The maximum water pressure is 6 bar (note: mains cold water is normally supplied at between 2 and 3 bar). For installations where the mains pressure exceeds 6 bar a pressure reducing valve should be fitted.

**Approvals**

All products are manufactured using materials tested and approved under the Water Bylaws Scheme and comply with requirements of British Standard 5412:1996 where applicable.

**Preparation and byelaw requirements**

These taps are single flow so the hot and cold water mix in the body. Water byelaws require that where the hot water is supplied from a tank and cold from the mains, non return valves are fitted on both hot and cold pipes as close as possible to the tap. These are not supplied. Where combination boilers are fitted it is only necessary to shut off the incoming mains and turn the boiler off and non return valves are not required.

**WARNING**

**Before installing the new mixer it is essential that you thoroughly flush through the supply pipes in order to remove any remaining swarf, solder or other impurities. Failure to carry out this simple procedure could cause problems or damage to the working of the mixer.**

These hints have been prepared for your guidance, you must exercise due care at all times. We do not accept responsibility for any problems that may occur through incorrect installation.

## DIMENSIONS

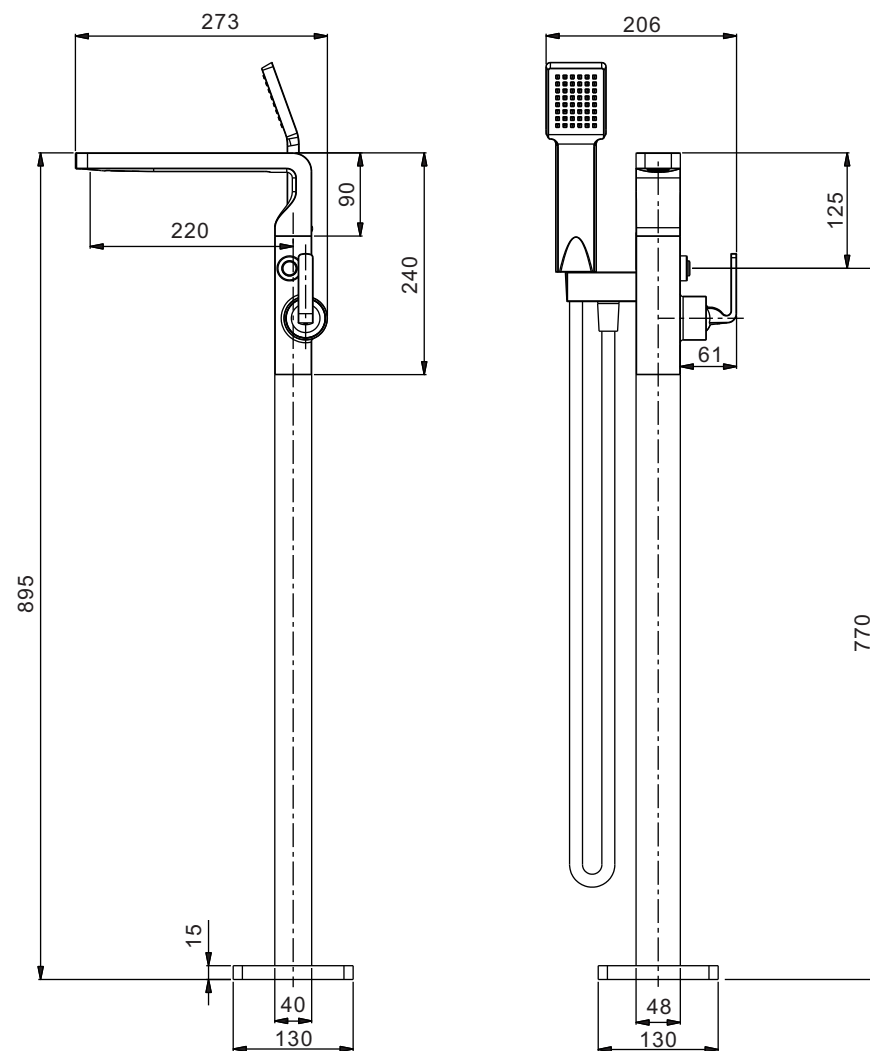

NOTE: ALL DIMENSIONS IN MILLIMETRES

INSTALLATION

The floor needs to be prepared by either making a cavity ranging from 54mm to 89mm in depth within a solid floor or putting support battening (suitable to take the weight and fixings) again at same depth within the floor cavity. (Please see Figure 1,2)

Figure 1

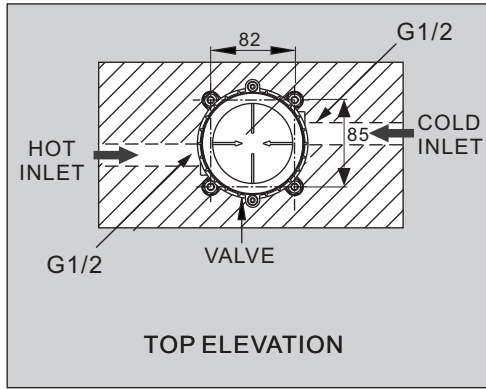
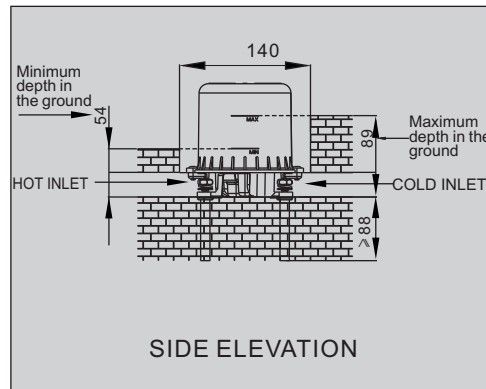

Figure 2



Then the floor mounting can be put in situ, the correct alignment is for one of the inlets to be pointing directly towards the bath. Once achieved secure in place with the floor bolts provided. At this point the water supply pipes can be worked up to and connected to the unit with 1/2 male BSP copper fittings using a proprietary thread sealer (such as PTFE Tape). The pipes should be flushed of all debris etc before final connection is made. (Please see Figure 3,4)

Figure 3

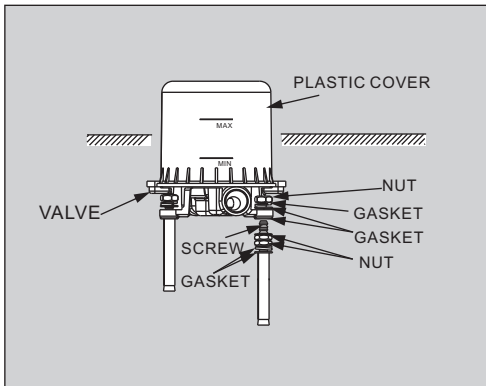
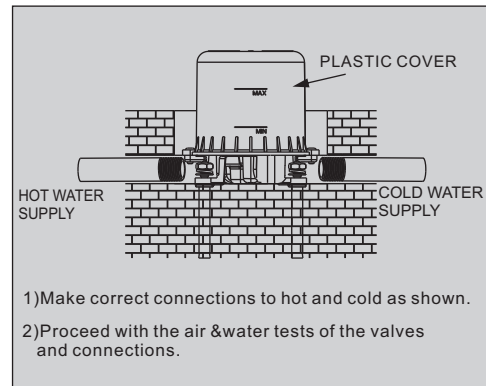
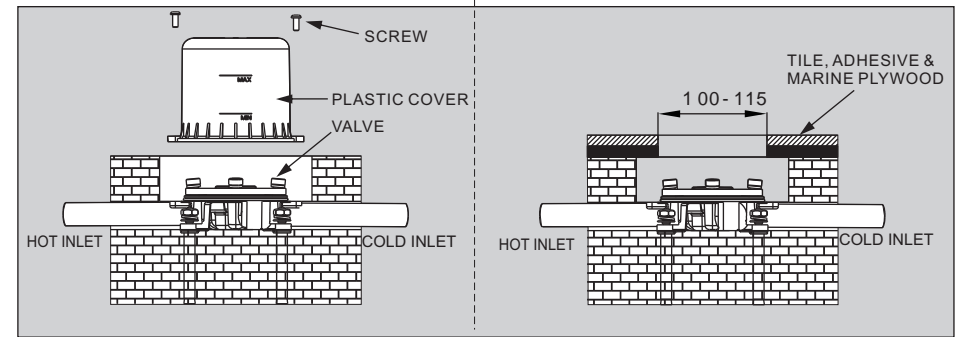

Figure 4



Once the testing is complete the plastic cover can be removed. The flooring can then be fitted to cover the void as shown below. The diameter needs to be circa 100-115mm in order to be covered by the decorative flange. (Please see Figure 5)

Figure 5



You will then see a plastic plate with two plugs / plastic covers are inserted into the outlets at the top of the body. Four screws should be removed (Attention: Remember to keep these 4 screws so as to use in the installation of the faucet body). These were to allow the water tight connections of the supplies to be tested before the main product is fitted. Now testing is complete a screw can be inserted into the hole to allow the plugs to be pulled out with any two of the four pliers'. (Please see Figure 6)

Figure 6

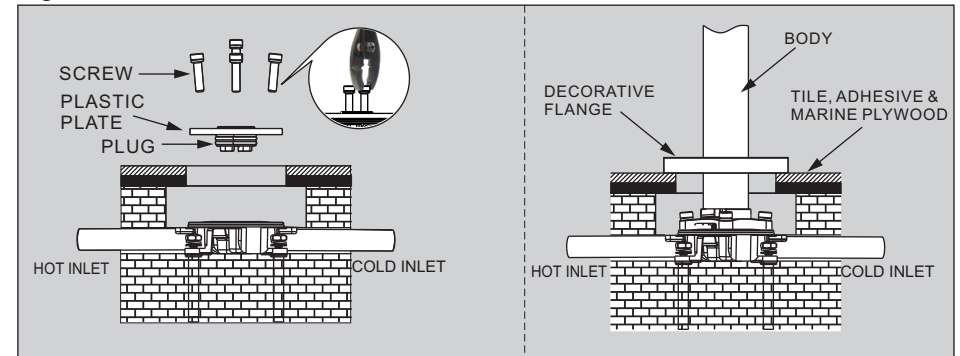

On the main body of the product slide the cover plate up the upstand taking care not to mark the chrome.

**INSTALLATION**

Next the two internal copper supply pipes should be pushed down into the corresponding holes of the floor mounting bracket. This is a pre-tested product so care should be taken not to put undue stress on these tails as this could damage the seal within the body of the tap itself. Finally the upstand can be tightened onto the floor mounting using the grub screw. (Please see Figure 7)

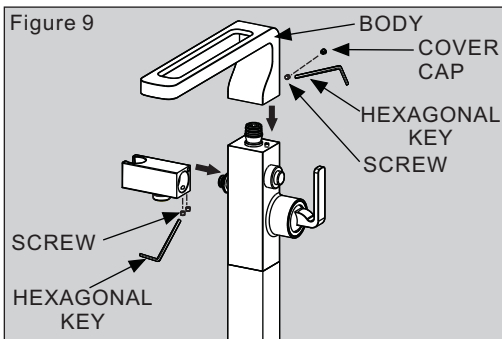
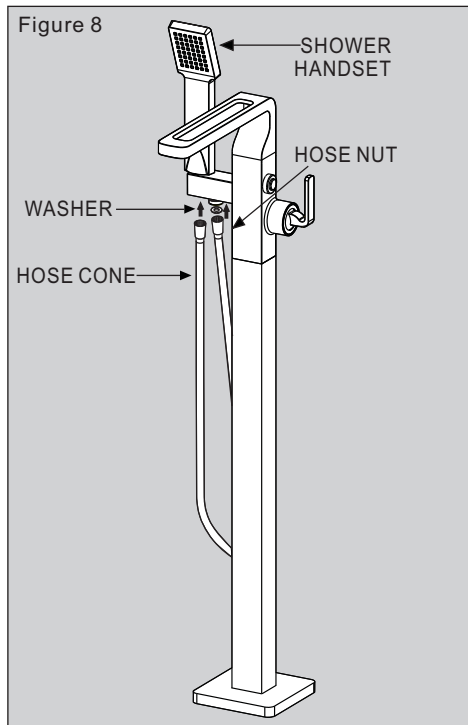
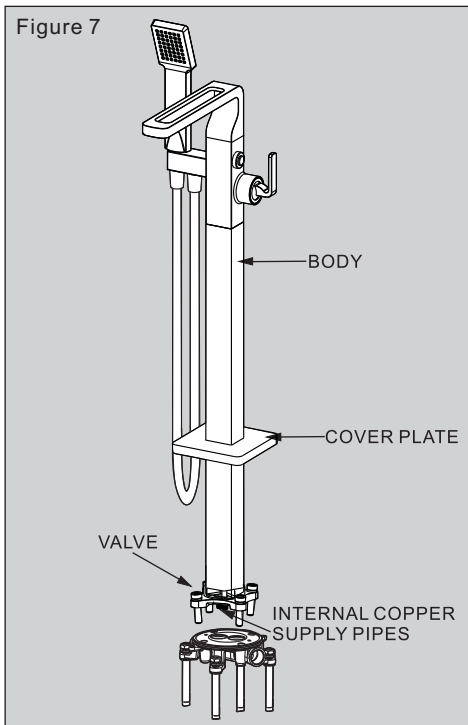

NB. At this point the water can be switched on and the unit tested for leaks. Extra care and time should be taken examining the base of this as it will be concealed once the installation is complete. Finally the handset bracket, handset and hose can now be connected to the unit. (Please see Figure 8 and 9)

**ATTENTION**

Having done final check of all new connections, turn on the mains stop cock, close all taps except the new mixer and as the system starts to refill check for leaks. Once you have satisfied yourself that there are no leaks, switch on the water heating.

**MAINTENANCE**

**CLEANING THE CARTRIDGE**

First make sure the water supply to the product is turned off. Then unscrew the pin on the mixer handle using a soft claw spanner or cloth taking care not to mark the chrome. Use the hexagonal key provided to loosen the grub screw sufficiently to allow the handle to be removed. Then remove the cover and retaining nut to access the cartridge. Taking note of the cartridges orientation remove it and rinse thoroughly under clean running water until all loose debris is removed. Replace the cartridge in the original position and fix in position with retaining nut and cover, prior to refitting the handle.

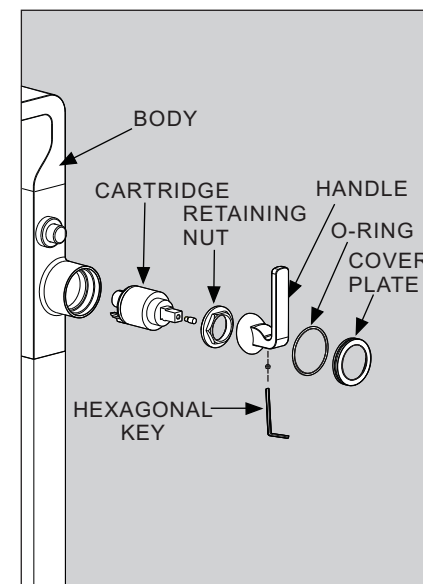

**CLEANING**

The chrome and gold plate we use on our taps is very durable, nevertheless care should be taken when cleaning them. They should be cleaned only with warm soapy water followed by rinsing with clean water and drying with a soft cloth. All finishes are vulnerable to acid attack and some strong substances such as household cleaners, disinfectants, denture cleaners, hair dyes, wine making and photographic chemicals can cause the surface to go black or peel.