

ADAPTABLE WASTE PUMP FOR SHOWER

SHOWER PUMP

SHOWER & BASIN WASTE PUMP

Installation and Utilization Instructions



WARNING!!!

1. Please read the manual carefully before installation
2. Avoid chemical solvents, strong acids and alkali entering the machine
3. Only toilet paper, fecal matter and waste water can be disposed Do not throw any other kinds of waste into the toilet
4. Shower waste can be disposed without a cutter
5. Avoid too much hair into the machine
6. When installing the device, placing a check valve is necessary
7. Make sure that waste water flowing from equipment automatically enters the pump
8. Keep the device dry and away from humid environments
9. Do not let children play with the machine
10. Maintenance should only be performed by qualified professionals
11. Disable electrical power and remove the plug from the socket before performing repairs on the device
12. Install a leakage protector socket & earthing conductor

Technical

Power:	250W	Voltage:	220~240V /50Hz
Horizontal discharge:	80M	Vertical discharge:	8M
Max. Water temperature:	80°C	Thermal protection:	100°C
Max. flow rate:	100L /Min	IP rate:	IPX7

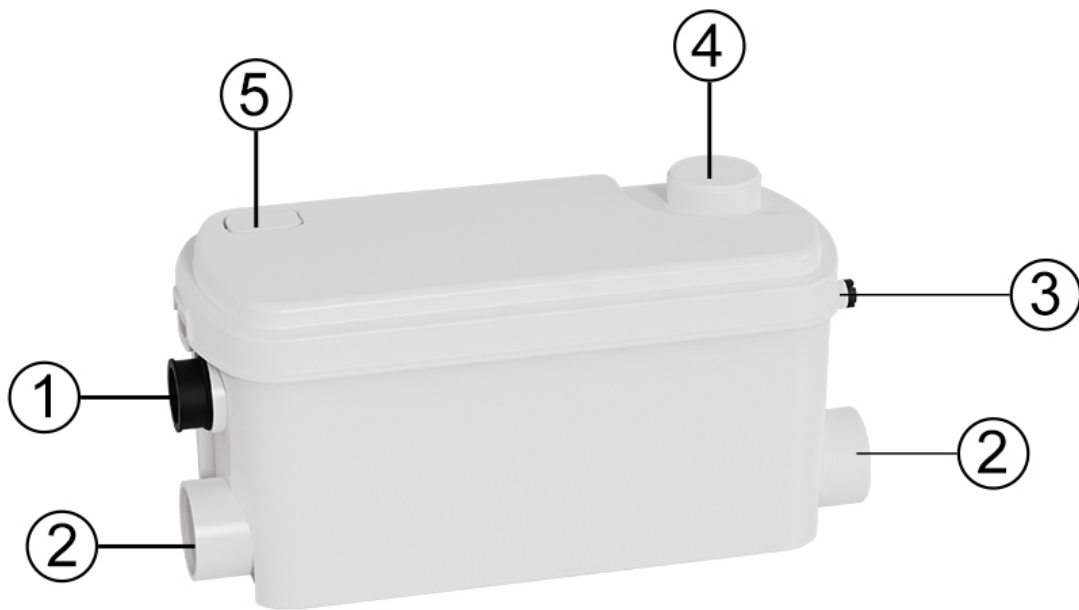

① Outlet ϕ 23/28mm	② Inlet ϕ 40mm
③ Air condition inlet or Exigency Outlet	④ Inlet ϕ 40mm (Optional)
⑤ Air-vent (Carbon Filter)	

Fig1: Size

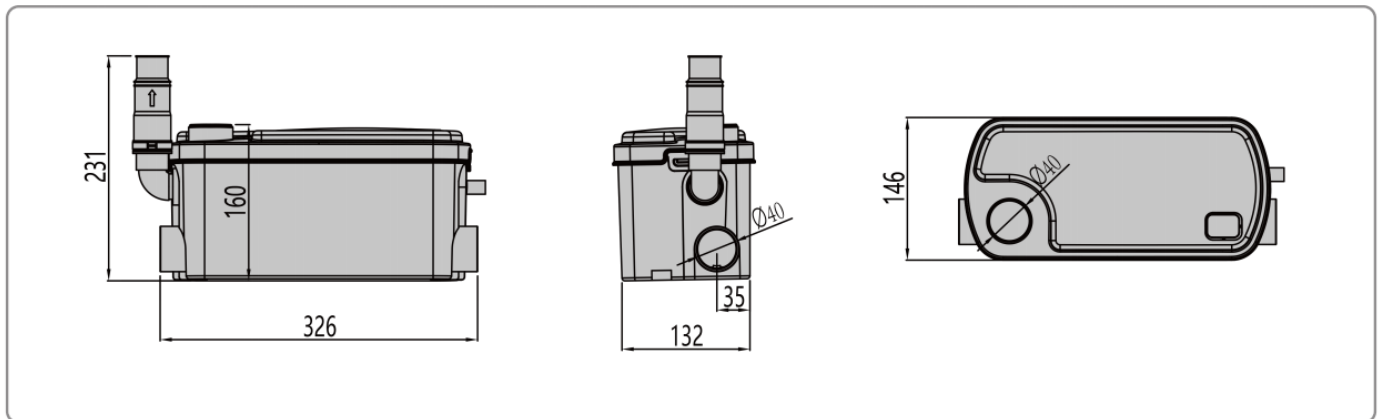

Fig2: Spare parts

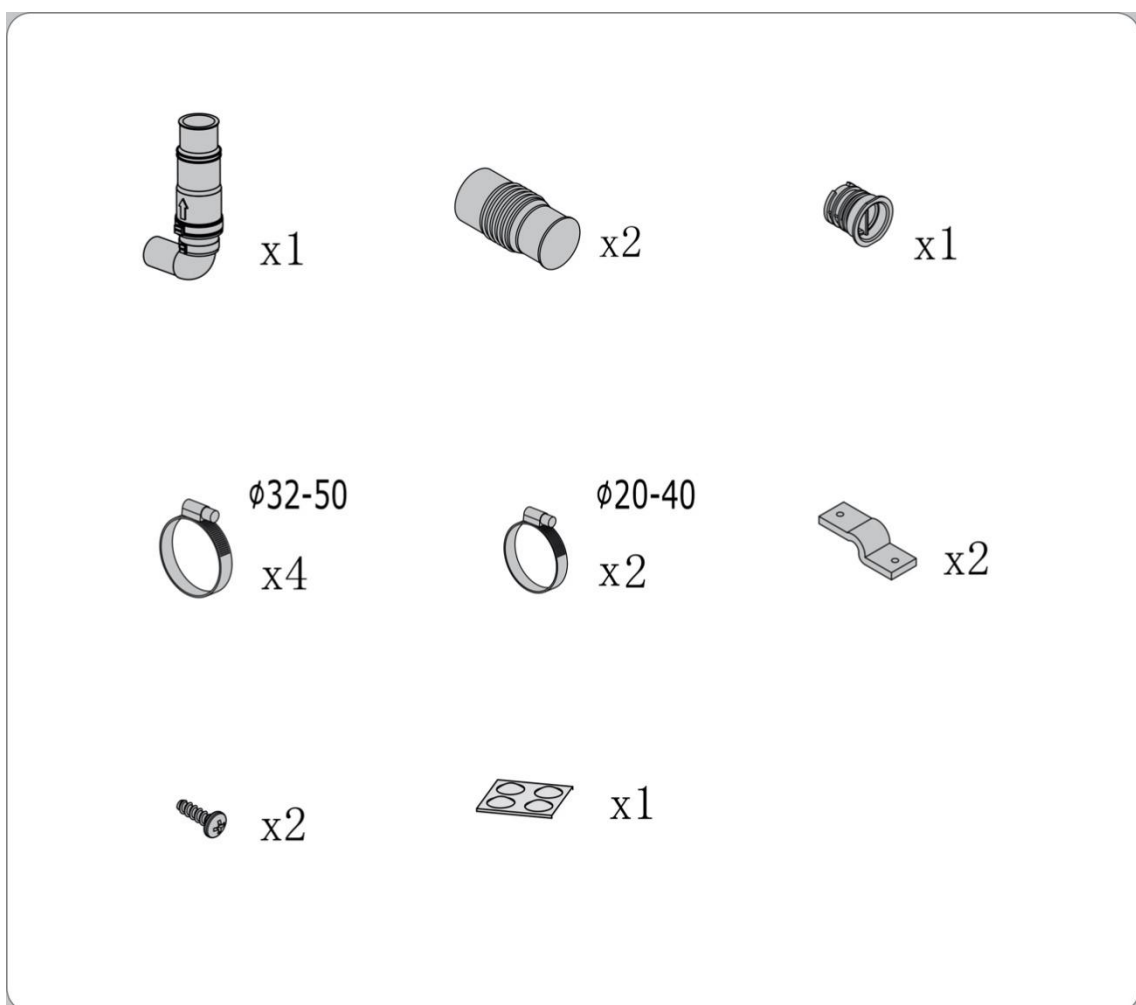

Fig3: Equipment

- 1, Outlet check valve is necessary
- 2, Install an extra manual check valve for repair (Suggestion)
- 3, Lift the shower 11cm high, when you connect the side inlet
- 4, Using filter in shower & lavatory to reduce hair come into machine

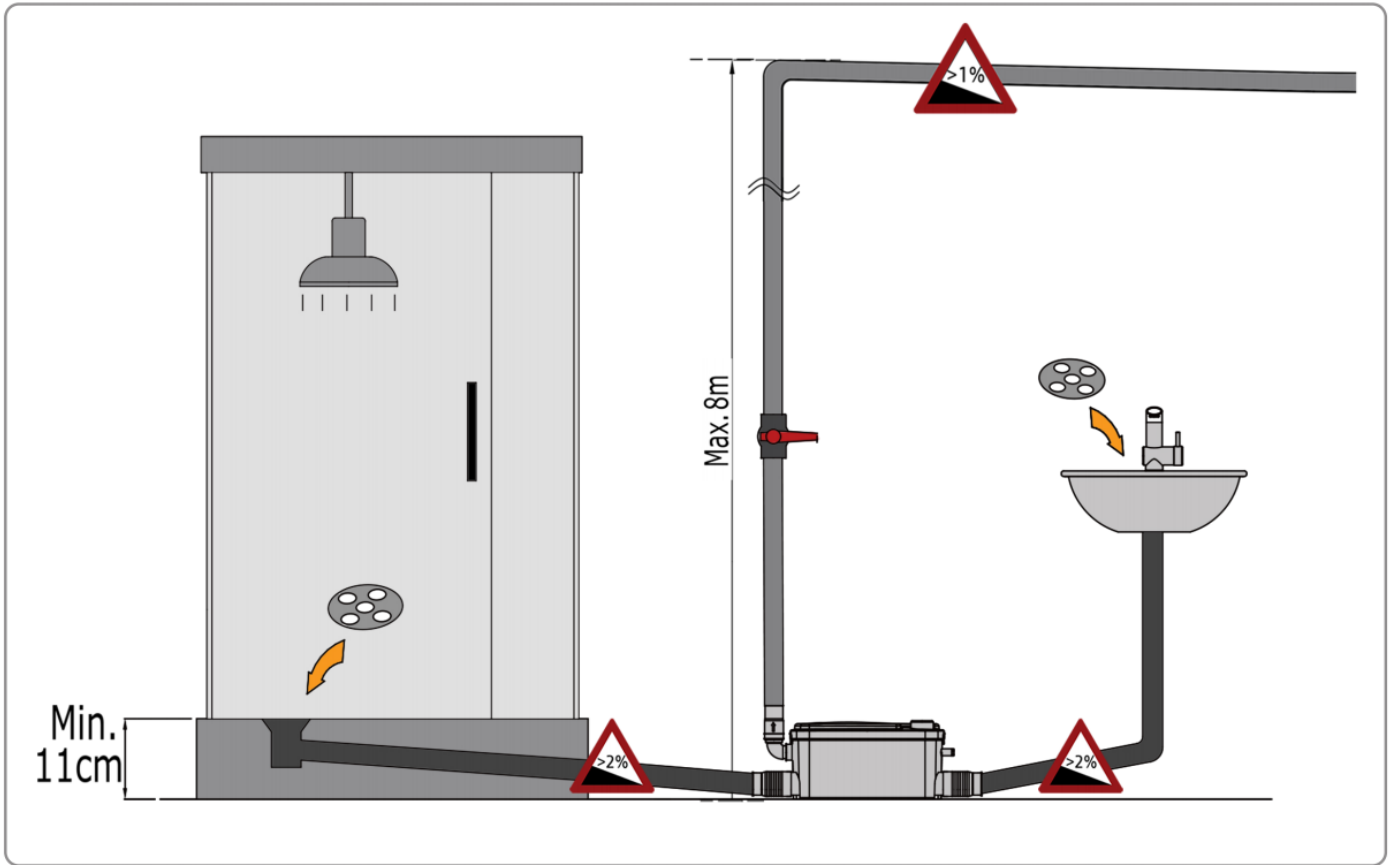

Fig4: Connection

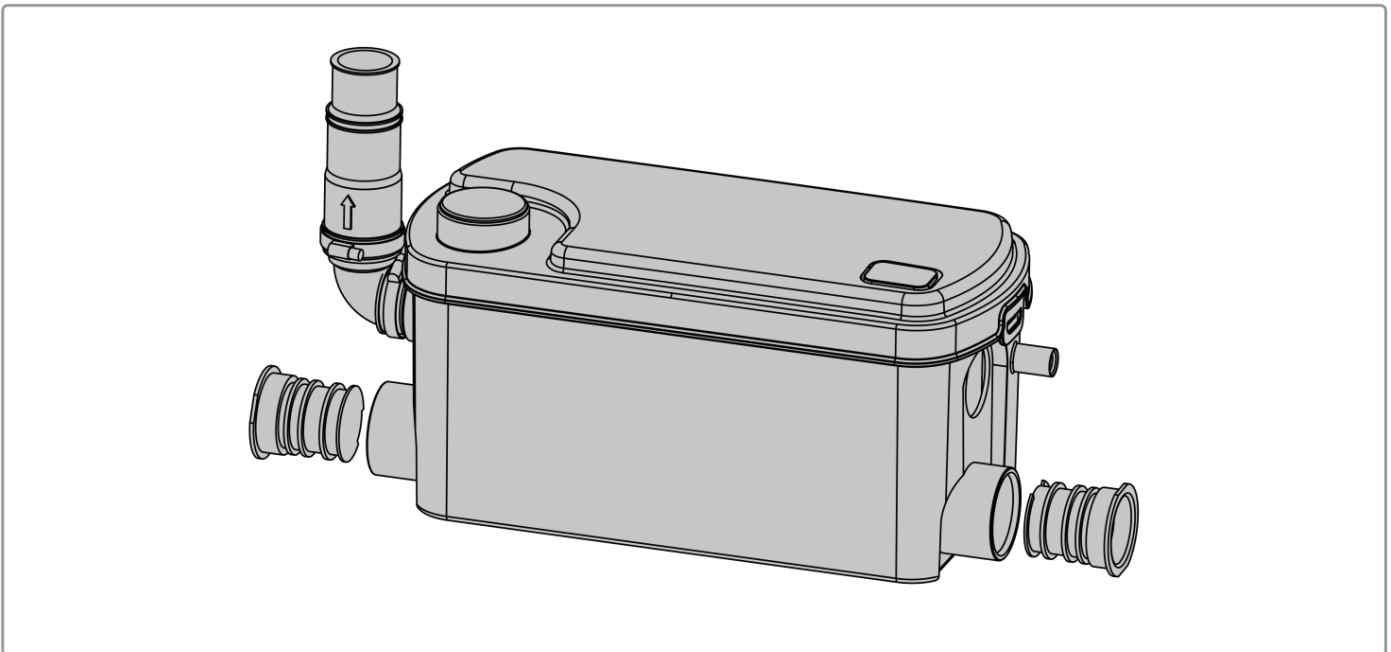

Fig5: Inlet cover (Cover the inlets for unused)

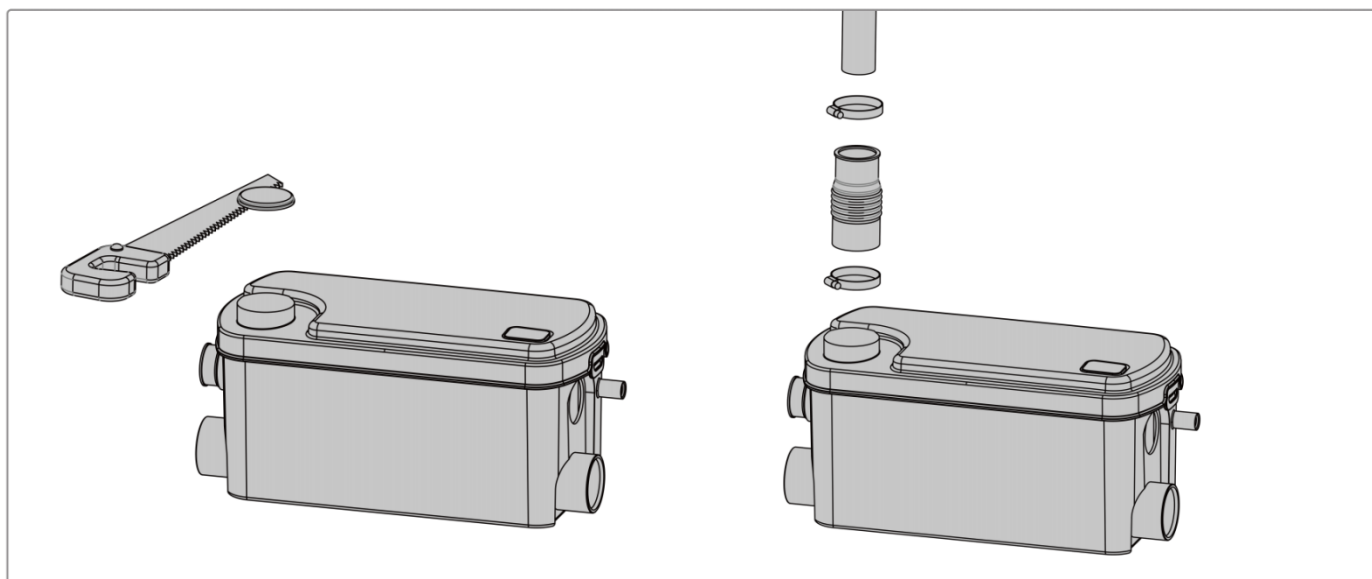

Fig6: Fixation

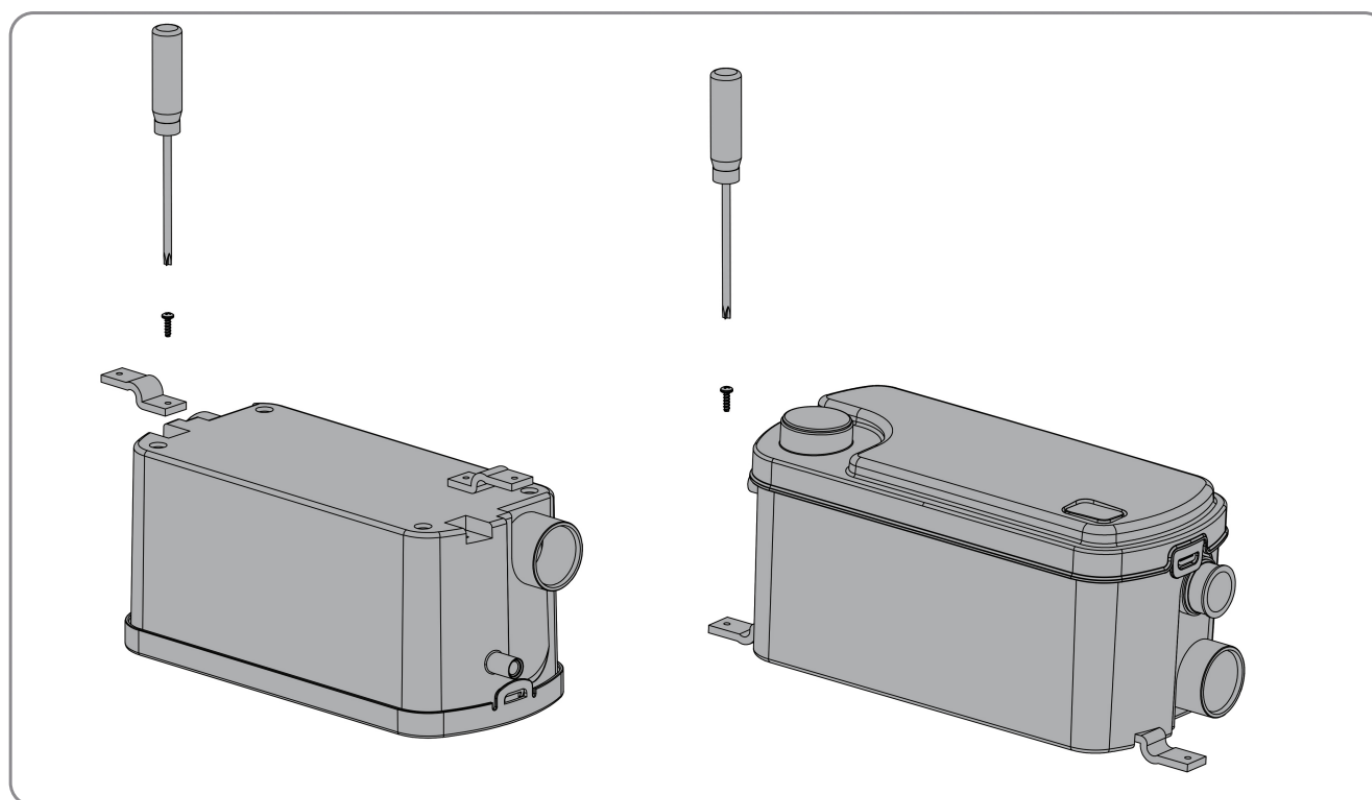

Fig7: Outlet (Check Valve 23/28mm)

Discharge pipe insert the check valve is only 1~2CM, avoid too much insert

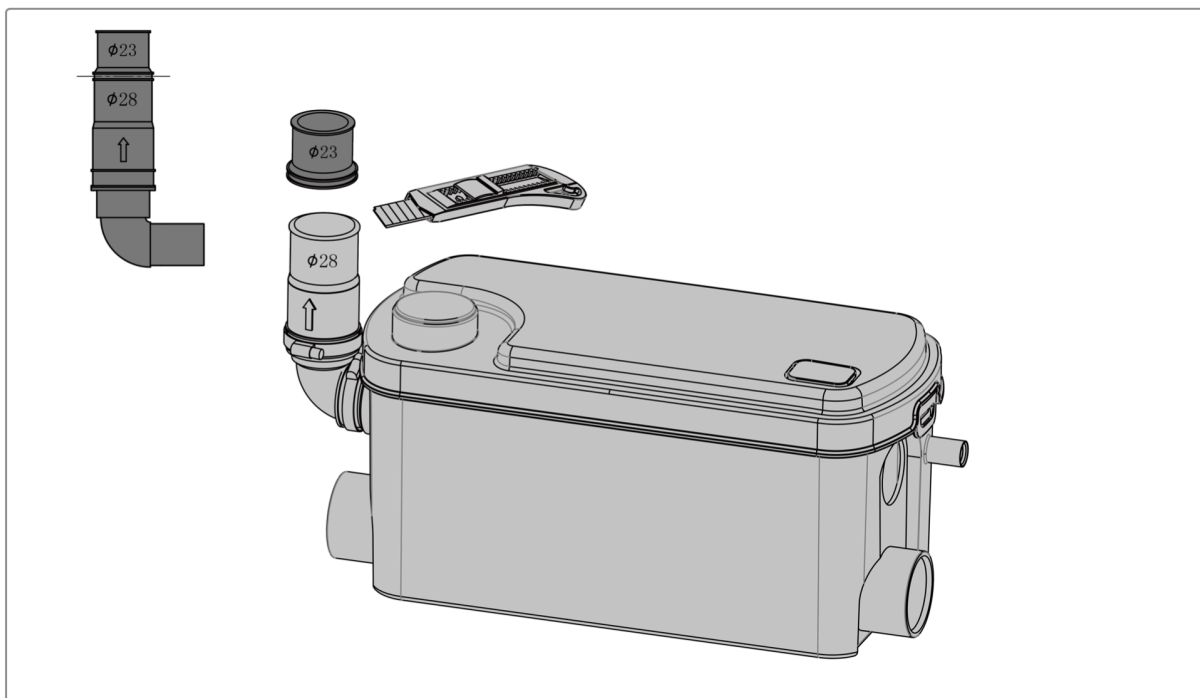

Fig8: Pumping head

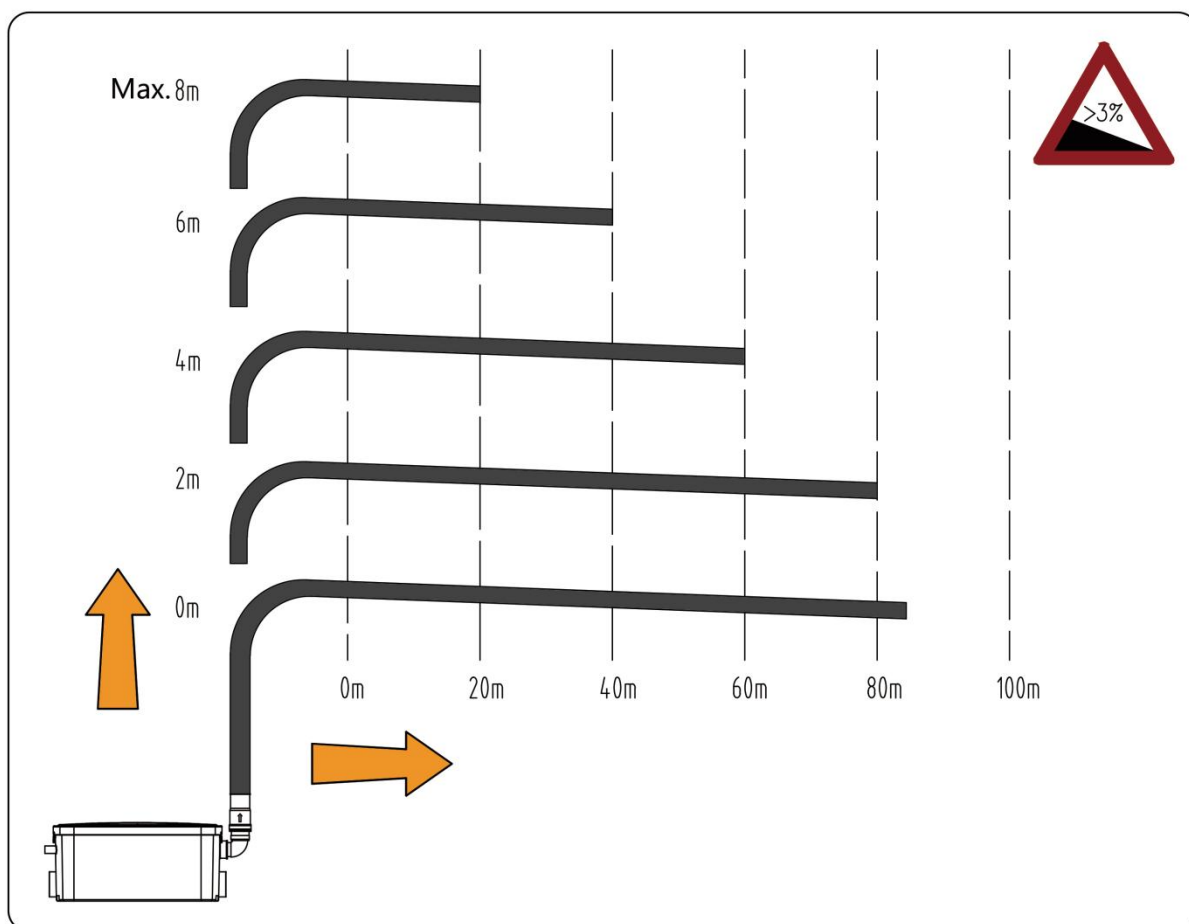

Fig9: Flow Rate

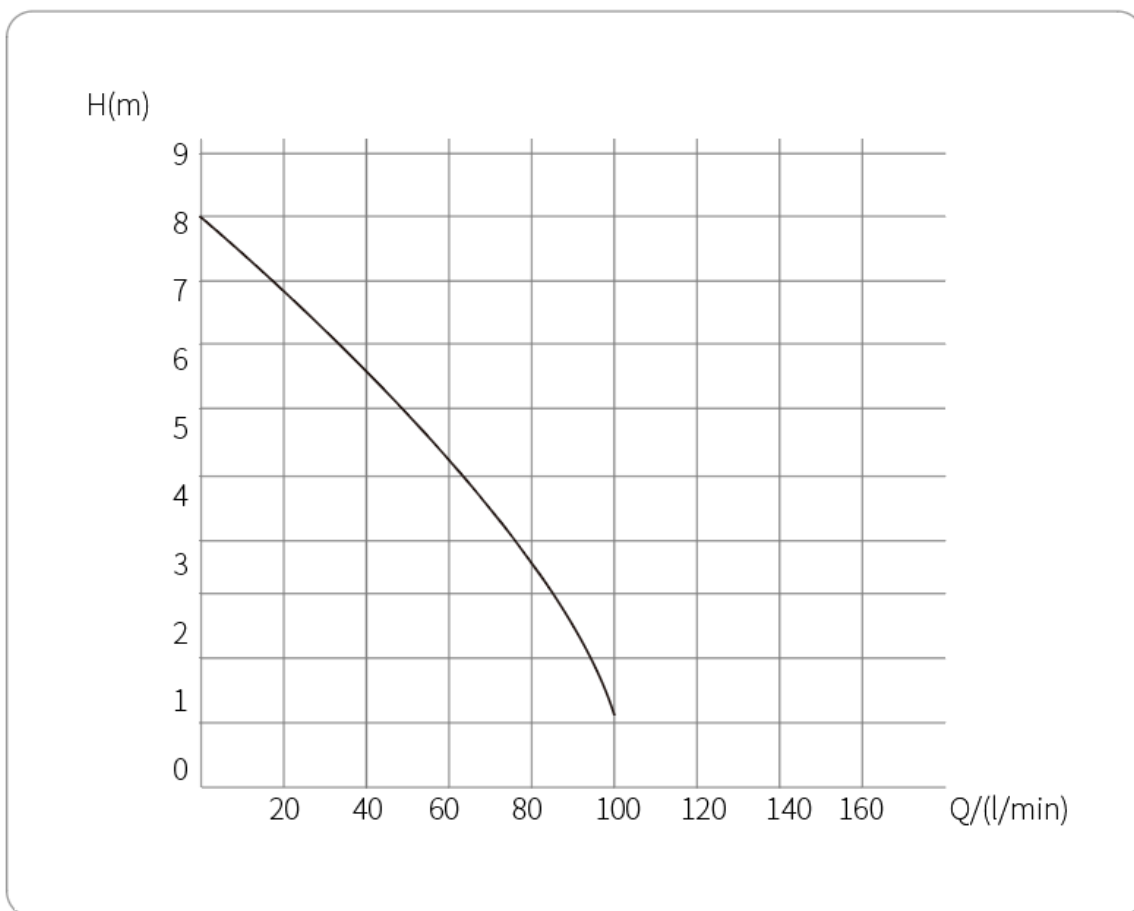

Fig10: Min Size below the shower is 150mm

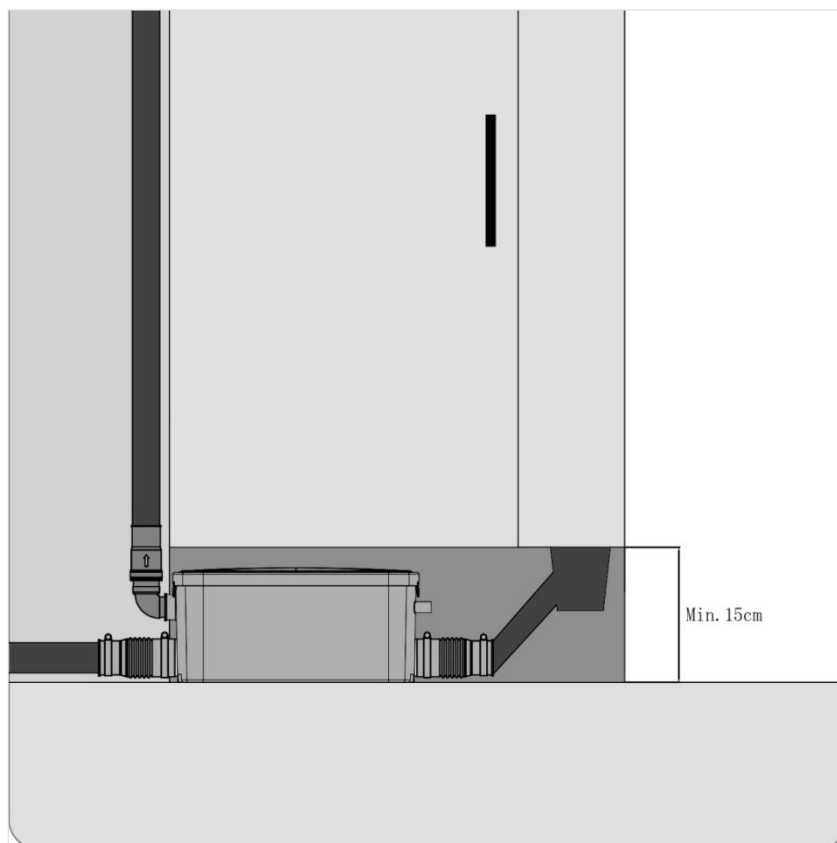

Fig11: angle

We suggest to using 2pcs 45' elbow to instead of 1pc 90' elbow

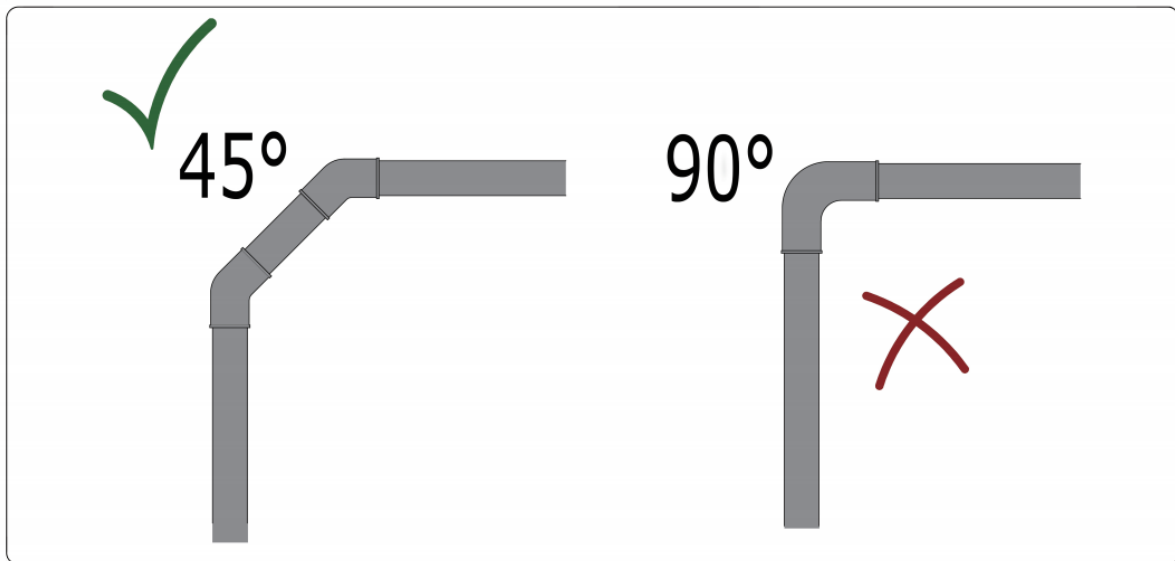
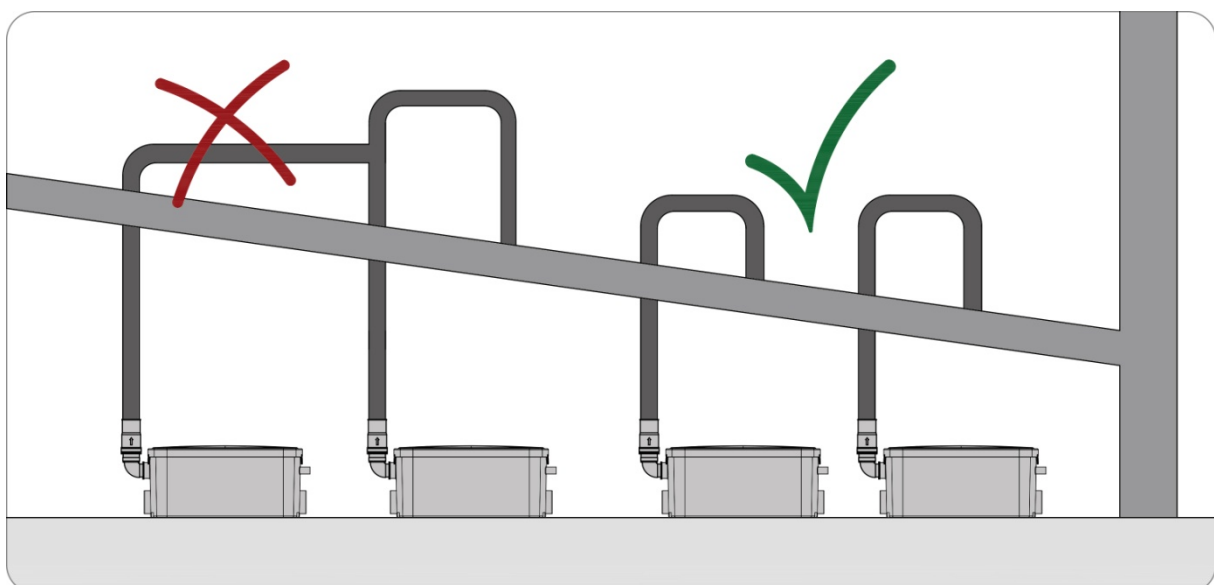
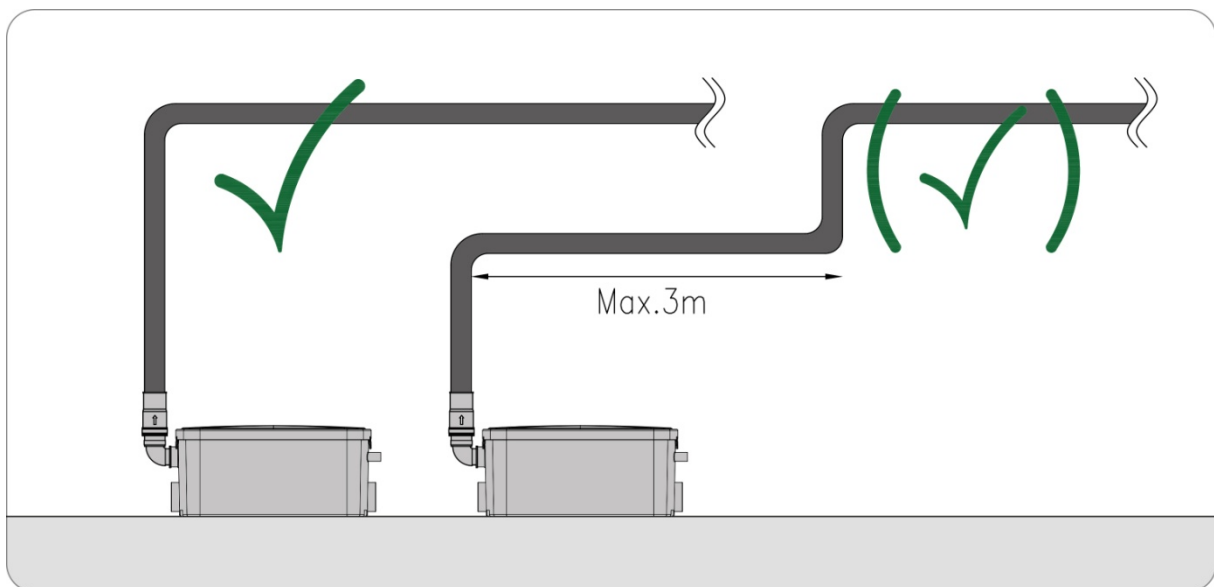

Fig12&13: Discharge Pipe connection



1. Warning

- The appliance is only ready for use after installation.
- The appliance must be supplied through a residual current device (RCD) having a rated residual operating current not exceeding 30mA.
- If the supply cord is damaged, it must be replaced by the manufacture or its service agent or a similarly qualified person in order to avoid a hazard.
- This appliance is not intended for use by persons (including children) with reduced physical, sensory or mental capabilities, or lack of experience and knowledge, unless they have been given supervision or instruction concerning use of the appliance by a person responsible for their safety.
- Children should be supervised to ensure that they do not play with the appliance.
- This appliance is of domestic use only

2. NOTICE

In order to ensure optimal performance of this appliance, the installation and maintenance instructions, described in this notice, must be strictly followed.

“ATTENTION” Referring to specific instructions, which if not respected, may cause the appliance to malfunction.

In order to enjoy maximum benefit from this appliance, please read the assembly instructions given

Note that this pump is not suitable for underground installation and not to be installed in hazardous locations.

3. GENERAL DESCRIPTION

This appliance may be used to pump waste water produced by basins and showers in a domestic situation.

4. INSTALLATION

The appliance must be installed in such a way as to ensure easy access for repair and maintenance. Installation must be carried out by a qualified person.

5.1 ELECTRICAL CONNECTIONS

All electrical connections must comply with local codes in your region. The current must be single phase 220V/50Hz. The electrical outlet must be located at a minimum distance of 1000mm from the shower or bath. Only connect this appliance to a safety protected circuit.

5.2 STARTING AND OPERATING INSTRUCTIONS

Run the water from the bathroom or from kitchen appliance connected to the pump and check that connections are water tight and that the pump starts and stops correctly.

The pump starts automatically as soon as the bath, the shower or the sink begins to drain. It shuts down when all the water has been drained.

Note that the pump will work intermittently as the pump will turn on and off or several cycles until it discharges all the water.

“ATTENTION”: Never drain alkaline or acidic liquids, solvents, Oils, paints paint strippers, food leftovers, or bleaches that may jam, damage or corrode this appliance.

In case of power failure, do not use any of the bathroom appliances connected to the pump, because they will not function properly until power is restored.

Never submerge pump entirely under water nor allow water to seep in through electric wire access.

Make sure that all faucets are fully shut otherwise the motor may stop and start, leading to a short circuit. This may also lead to flooding.

If you do not plan to use the pump for a long period of time (vacation, major power shortage, maintenance, renovation), shut off water).

In regions prone to frost and freezing, the appliance must be adequately protected against freezing. This requires emptying all pipes and the pump body. Antifreeze may be used to protect the system. Pour 1 liter of antifreeze into a sink connected to the pump. This will activate the pump and any remaining water will be replaced by antifreeze. Neither labor nor parts are covered if the appliance is damaged by frost or freezing

6. SERVICE

Disconnect power before working on the appliance

This appliance does not require any particular maintenance. In case of appliance failure, all repair work must be performed by a professional workers.

This applies particularly when replacing power cord.

7. WARRANTY

This HOMAC 250 appliance bears a 1 year warranty starting from date of purchase, subject to proper installation and use, in compliance set out in this notice

8. TROUBLE SHOOTING GUIDE

PROBLEM	CAUSE	SOLUTION
Motor runs properly, but pump does not drain water	Clogged drain pipe or valve; Outlet valve is half closed	Clean pipes and valves. Check outlet valve
Pump doesn't start; water doesn't drain	Clogged ventilation duct	Clean ventilation duct
Pump does not start, water doesn't drain	Power cut off. The thermal limit switch does not work	Wait for thermal limit switch to come on (about 20 minutes)
The motor hums but doesn't turn on	Foreign body obstructing pump. Defective condenser	Check the pump
Water drains, but motor continues to run for a long time and the thermal limit switch is activated	Drain pipe blocked or twisted; damaged membrane, gear wheel damage, pump partially blocked	Check for blockage
After draining, motor restarts several times before shutting down	Water flows back to pump, back flow valve does not work	Flush once or twice with clean water to clear valve or remove valve and clean
Motor is running with loud noise, but does not drain or shut off	Back-siphonage or poor counter pressure in drain pipe, causing air pockets; Presence of foreign body	Modify drain pipe in order to prevent back-siphonage or to increase counter pressure (for example, use smaller pipes and add a curve to pipe). If problem persists, consult a certified technician
Motors runs, but makes strange noise	A solid body is in pump	Consult a certified technician
Water flows back to bath or shower	Insufficient gravity flow. Inlet valve defective	Ensure that gravity flow is at least 1/4 inch at 12 inches between other bathroom appliances and pump. Clean inlet valves

9. MAINTENANCE



DISCONNECT THE ELECTRICAL POWER SUPPLY, BEFORE ATTEMPTING ANY WORK ON THE UNIT.

No need of any particular maintenance.

This unit is fitted with an active carbon filter, and requires no external venting.



Correct disposal of this product

This marking shown on the product or its literature, indicates that it should not be disposed with other household wastes at the end of its working life. To prevent possible harm to the environment or human health from uncontrolled waste disposal, please separate this from other types of wastes and recycle it responsibly to promote the sustainable reuse of material resources.

Household users should contact either the retailer where they purchased this product, or their local government office, for details of where and how they can take this item for environmentally safe recycling.

Business users should contact their supplier and check the terms and conditions of the purchase contract. This product should not be mixed with other commercial wastes for disposal