

## Slotted/Unslotted Flip-Top Basin Waste

### Before you Begin:

- This instruction shows how to fit the Flip-Top basin waste. Ensure the chosen waste is applicable to your chosen basin and is the correct size for the basin waste hole.
- **Slotted - Designed for use with basins with an overflow.**
- **Unslotted - Designed for use with basins without an overflow.**
- Ensure the incoming mains water supply is switched off prior to commencing the installation.
- Unpack the product then read these instructions before proceeding. Inspect the product for damage. If any damage is found, contact our Customer Relations team.

① \*Make sure that all components are present prior to installation.\*

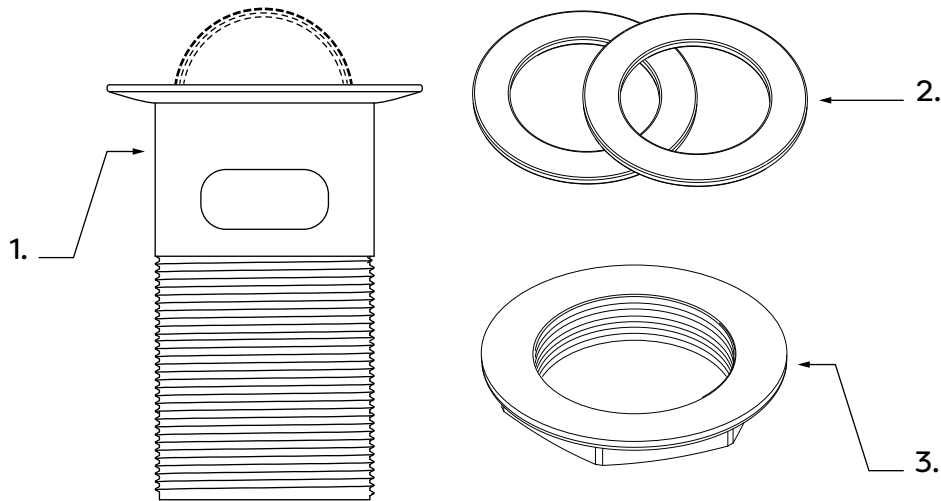

### Fitting List:

1. Flip-Top Waste (Slotted/Unslotted)
2. Rubber Seal (X2)
3. Back Nut

**Note:** Diagrams are for illustration purposes only. Your Flip-Top Waste may superficially differ from this drawing however the installation guide steps still apply.

### Recycling and Disposal:

- Please recycle the packaging in accordance with your local government regulations on waste handling and follow the same advice at the end of the products life.

②

### Installation tip:

Pipe a fine bead of good quality silicone sealant around the top and bottom edge of the basin waste hole.

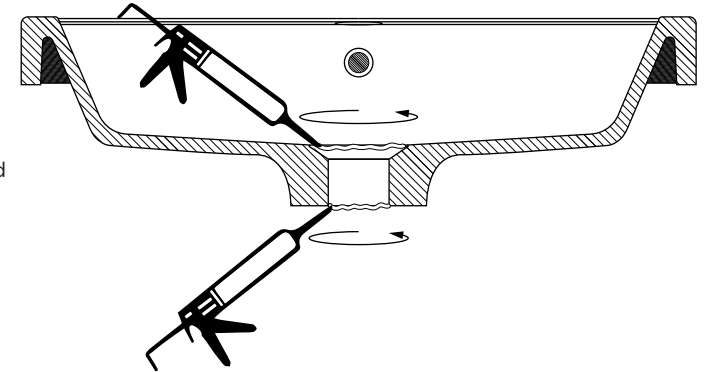

③

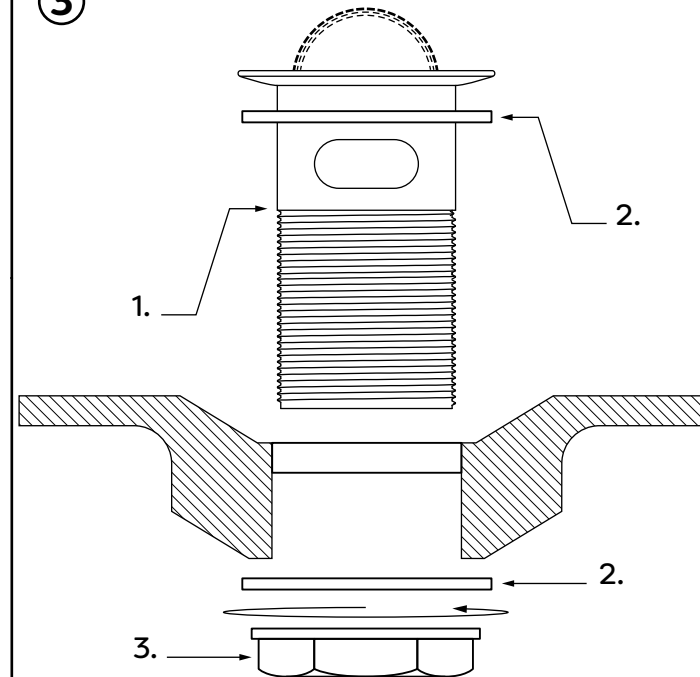

Place a 'Rubber Seal' (2) over the threaded tail of the 'Flip-Top Waste' (1). Proceed to feed the 'Flip-Top Waste' through the basin waste hole.

Place the second 'Rubber Seal' (2) and 'Back Nut' (3) over the threaded tail of the 'Flip-Top Waste'. Tighten the 'Back Nut' to secure the Waste into position.

Wipe away any excess silicone with a damp cloth.

**Note:** Test the installation and check all joints/connections for any leaks.

### Cleaning and Aftercare:

- To clean the Flip-Top waste; open the plug, wipe clean then close the plug.
- **Warning:** Do not use abrasives, scourers, bleach or any type of chemical cleaning solution when cleaning the pop-up waste. It is recommended to use warm soapy water and a clean damp cloth.

For more information visit: [www.victorianplumbing.co.uk](http://www.victorianplumbing.co.uk)