

## **IN-SERVICE TESTING**

The purpose of in-service testing is to regularly monitor the thermal performance of the thermostatic mixing valve. Deterioration in performance can indicate the need for service work to be carried out on the system.

If the authority concerned does not have a planned test and maintenance schedule then the suggestions below should form the basis of a new system.

At intervals of 6 - 8 weeks and 12 - 15 weeks after commissioning:-

1. Check supply parameters are still within the expected values if not check system for faults.
2. Carry out commissioning procedures a to c using the same test equipment, if the mixed water temperature has changed a significant amount (by more than 1K) check to ensure in line filters are clean, that the check valves are working and all isolating valves are fully open. If no fault can be found check and record the mixed water temperatures and readjust mixed water temperature to the values in table 2. Complete the commissioning procedure a to e if the mixed water temperature exceeds the values of the maximum recorded temperature by more than 2K the need for service work is indicated.

Depending on the results of these two tests the following should be adopted

- a) If a small change (e.g. 1K to 2K) occurs in one of these tests or there is no significant change (e.g. 1K maximum) then the next in service test should be 24 to 28 weeks after commissioning.
- b) If small changes occur in both tests or a larger change occurs in one test (exceeding 2K) then the next in service test should be carried out 18 to 21 weeks after commissioning.

These results can then be used to set a service interval which tests have shown can be used with no more than a small change in mixed water temperature. This method of determining service intervals is used to take into account various in-service conditions (i.e. water condition) that the valve may experience.

Customer Care  **0844 7016273**

# BRISTAN



## **Installation, operating and maintenance instructions for Gummerts H64WMT & H64DMT**

### **Sequential Integral Thermostatic Bib Tap**

Before installing or operating this tap please read this manual carefully and retain it for future reference.

Bristan operate rigorous quality control procedures but in the unlikely event of finding this pack incomplete, or needing further technical information please contact the manufacturer.

LP - WE LOW PRESSURE ECONOMY WASH BASIN  
HP WE HIGH PRESSURE ECONOMY WASH BASIN

### **BristanGroup Limited**

Birch Coppice Buisness Park

Dordon

Tamworth

Staffordshire

B78 1SG

Tel: 0844 7016274

Free fax Order Line: 0808 1611002

Email: [customercare@bristan.com](mailto:customercare@bristan.com)

Website: [www.bristan.com/trade](http://www.bristan.com/trade)

## Introduction

The NHS is aware that users of hot water in care establishments can be at risk from scalding and in order to minimise that risk and reduce the incidence of legionella thermostatic mixing valves are generally used. To ensure the performance of these products the NHS Estates Model Engineering Specification DO8 was written. This product is independently certified to comply with that specification for use as a hand-washing device on both high and low pressure. This fitting is designed to have the following advantages: -

- 1) The temperatures of the exposed surfaces in normal use will not cause skin damage.
- 2) Integral in front of panel isolation and union connections allow the complete unit to be removed for workshop servicing.
- 3) Integral flushing system allows the mixed water chambers to be pasteurised reducing the risk of bio film growth.

It can be used in any situation where a thermostatically controlled temperature is required for hand washing or vessel filling.

This product is approved by Buildcert for the following designations:

Code	Operating Pressure	Application
HP - WE	High Pressure Economy	Wash Basin
LP - WE	Low pressure Economy	Wash Basin

## Conditions for normal use

In order ensure the product will perform within the requirements of the TMV3 scheme the operating parameters should comply with the table below, it may perform adequately outside these limits but an engineer should carry out a risk assessment to substantiate this.

	Low pressure	High pressure
Maximum Static Pressure	10 bar	10 bar
Minimum Dynamic Pressure	0.2 to 1 bar	1 to 5 bar
Recommended hot supply temperature	57 to 65°C	57 to 65°C
Recommended cold supply temperature	5 to 20°C	5 to 20°C
Minimal Temperature Differential between Mixed Water Temperature and Either Supply	10°C	10°C

## Specification

The flow rates (L/min) for the tap with and without flow limiters are quoted in the table below:

Pressure Drop bar	0.1	0.2	0.4	0.6	0.8	1	1.5	2	3	4	5	
Flow rate without limiters	4	5.8	8	10	11.6	12.9	No Flow Regulators					
Flow rate with limiters	With Flow Regulators						8.5	9	9.3	9	9	9

## **HTM64 SPARES LISTING**

ORDER CODE	DESCRIPTION
SKH64-1	O-RING SEALS KIT
SKH64-2	CARTRIDGE ASSEMBLY
SKH64-3	FLOW STRAIGHTNER
SKH64-4	HANDLE ASSEMBLY.
SKH64-5	INLET ASSEMBLIES (PAIR)
SKH64-6	COLD ELBOW ASSEMBLY (WALL MOUNT)
SKH64-7	HOT ELBOW ASSEMBLY (WALL MOUNT)
SKH64-8	COLD ELBOW ASSEMBLY (DECK MOUNT)
SKH64-9	HOT ELBOW ASSEMBLY (DECK MOUNT)
SKH64-10	WALL SHROUDS CHROME (PAIR)
SK1500-3	THERMOSTAT & PISTON ASSEMBLY
SK320078	PISTON ASSEMBLY
SK740012	THERMOSTAT

## NOTES

## Faultfinder

<b>Fault</b>	<b>Cause</b>	<b>Repair</b>
No or reduced flow and/or fluctuating temperature	One or both isolating valves not fully open  Flow limiters incorrectly fitted  Inlet pressures below specified values  Supply pipes blocked  Waterways in tap blocked  Supply pressures unequal	Open both valves fully  Check information and refit correctly  Alter system to increase supply pressures  Rectify system fault  Clear debris or call service department  Check maximum pressure differential, and check if flow limiters correctly fitted
Maximum outlet temperature too hot	Maximum mixed water temperature incorrectly set	Reset temperature see calibration section
Maximum outlet temperature too cold or runs cold after a short time	Maximum mixed water temperature incorrectly set  Hot water temperature too low	Reset temperature see calibration section  Increase water temperature by adjusting storage temperature or power input to the system
Mixed water flow too high	Flow limiters incorrectly fitted	See section on flow limiters
Only hot or cold water at outlet	Maximum mixed water temperature incorrectly set  Inlet supplies reversed	Reset temperature see calibration section  Re pipe supplies
Tap will not shut off or dripping	Seal damaged or worn  Scale build up in body  Inlet pressure above maximum static pressure rating	Renew seals from spare parts kit  Service and descale fitting  Reduce pressure possibly by fitting reducing valve
No thermostatic fail safe	Inlet temperatures outside specification  Debris trapped in mechanism or mechanism jammed  Inlet supplies reversed	Reset boiler or recirculation temperatures  Strip and clean unit or call the service dept  . Re pipe supplies

Inlets	15mm Compression or ½” BSP Male Iron
Outlet	24mm Flow Straightener
Minimum pressure drop through fitting for correct mixing	0.1 bar
Maximum Pressure Drop Through Fitting for Correct Mixing	5bar
Maximum static pressure to be applied to fitting	10bar
Mixed water temperature variation with nominal variations of supply parameters	± 2°C
Factory set maximum mixed water temperature	41°C
Maximum hot supply temperature	80°C
Maximum pressure loss ratio without flow limiters	5:1

## Installation

A competent person must always carry out the installation of this product in accordance with these instructions. The installation must comply with the current local water company regulations.

The following points should always be considered when carrying out an installation

- 1) Care must be taken to prevent any risk of injury or damage to persons or property.
- 2) The product has integral isolation for servicing the unit, further isolation could be included if considered necessary.
- 3) To eliminate pipe debris entering the valve the system must always be thoroughly cleaned and flushed particularly if it is new, or extensive modification has taken place. The product must never be used without the in line filters fitted; failure to fit the filters may invalidate the guarantee.
- 4) The fitting is supplied with a single check valve in each inlet; it should be fitted so that the relevant air gap specified in the water regulations is achieved above the spillover level of the basin or trough.
- 5) The surface to which the unit is to be fixed needs two holes minimum 23mm diameter maximum 30mm diameter at 150mm to 200mm centres (deck mount - variable centres) or approximately 172.5 mm (wall mount)
- 6) If fitted in a health care environment the relevant Health Technical Memorandum must be consulted to ensure correct positioning of the outlet in relation to the basin or trough.
- 7) The unit is supplied suitably configured for fitting onto a high pressure system if a low pressure system is to be used the flow limiters (item 16 and 17) must be removed see servicing for method.
- 8) When viewed from the front and the unit is connected to the supplies the Hot supply must be connected to the left hand inlet and the cold to the right hand inlet.

## **Calibration**

Due to variations in supply parameters from those used to set and test the products in our factory the outlet temperature will require resetting on site. The temperature will need to be set between 39°C and 41°C in order to comply with TMV3 approval this is done by fully opening the valve, using a thin blade remove the indice holder (45) with indice (46) still attached. Then inserting a 2.5mm hexagon wrench into the adjusting screw (32) and turning the screw clockwise for a cooler temperature and anti clockwise for a warmer temperature see Fig 1

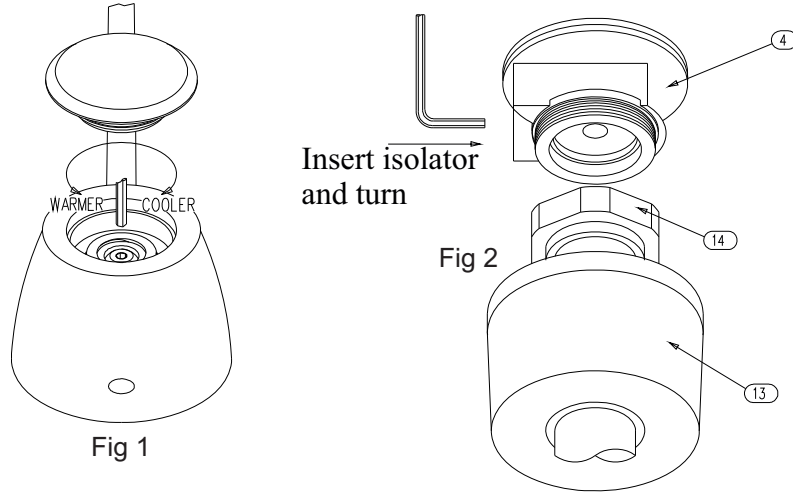

## **Operation**

The unit has a single control lever that turns the unit on and off and adjusts the temperature. Turning the handle anti clockwise from the off position firstly gives cold water flow then increases the temperature to the maximum set value.

## **Maintenance**

This product is designed to be easily serviced, it has integral isolation, integral hot water flushing to pasteurise the mixed water chambers reducing the incidence bio film growth and unions that allow the complete body to be removed for servicing in the workshop.

## **Isolating and removal of the valve**

The valve has integral isolation this is accessed by unscrewing the shroud (13) and pulling it back along the elbow taking care not to scratch the chrome, the 2.5mm hexagon wrench is inserted in the isolating plug (6) and rotating it clockwise until it locks. The securing nut (14) is then removed whilst supporting the valve to stop it falling and damaging the surface below it. The valve can then be replaced or serviced as is most convenient. The valve is replaced by reversing the above procedure ensuring the O-ring is undamaged and in place.

The purpose of this section is to ensure the valve is adjusted correctly for the system in use.

The supply pressures and temperatures should be checked to ensure they are within the requirements of DO8 and the flow limiters set as per the above table. The fitting should be run for several minutes until the mixed water and incoming water temperatures have stabilised, the mixed water temperature should be adjusted as per the calibration section above,

The cold water to the fitting should be isolated the mixed water flow should reduce to a drip or small run, the cold water reinstated and the temperature should recover close to the original temperature.

The following information should be recorded

- a) The temperature of incoming supplies.
- b) The temperature of mixed water outlet under normal running.
- c) The temperature of any residual flow after cold isolation.
- d) The temperature of mixed water outlet under normal running after isolation.
- e) Record the identity of all instruments used.

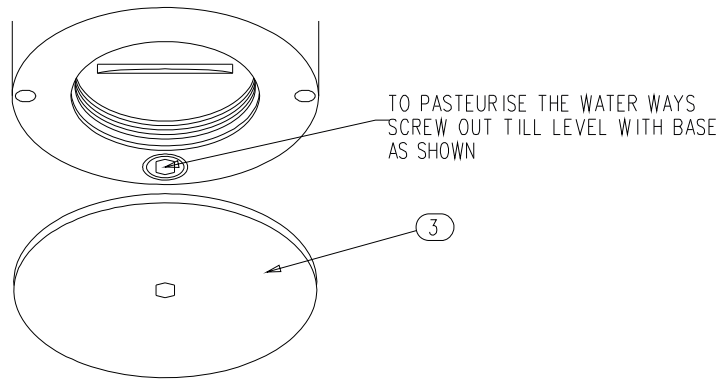

Fig 4

The following steps are required: -

- 1) Ensure the fitting is turned off
- 2) The cold water isolator should be closed, this is accessed by unscrewing the shroud (13) and pulling it back along the elbow taking care not to scratch the chrome, the 2.5mm hexagon wrench is inserted in the isolating plug (6) and rotate it clockwise until it locks.
- 3) The back cover (3) is unscrewed using a 2.5mm hexagon wrench and put to one side.
- 4) The flushing screw (19) is unscrewed downwards till it is level with the bottom of the body (do **not** remove completely) see Fig4.
- 5) Turn the fitting on, hot water at the inlet temperature will pass through the unit pasteurising the waterways and flow straightener.
- 6) Turn the fitting off.
- 7) The flushing screw (19) is screwed upwards till it locks.
- 8) Replace the back cover (3) , reinstate the cold water and replace the shroud (13).

The unit is now ready for use.

### Commissioning

If the authority concerned already has a suitable commissioning and maintenance program in operation then this section can be disregarded. If not this section can be used as a guideline to introduce such a system. The purpose of any commissioning and in service testing procedure is to set the valve correctly and monitor any deterioration in the valves thermal performance.

### Cleaning integral filters

The integral filters are fitted into the inlet elbows to the fitting. The fitting should be removed from the bases as described in the previous section the filters are then accessible for servicing as shown in Fig3. They are a friction fit into the adaptors and should be carefully prised out washed and refitted. Failure to refit the filters may invalidate the guarantee.

### Flow limiters

As supplied the fitting has flow limiters fitted to both inlets so it is suitable for high-pressure use. For use on low pressure they may need to be removed see table below. The procedure described above for cleaning the filters should be followed. After removal of the filter the flow limiters are visible and should be removed using a small pointed instrument.

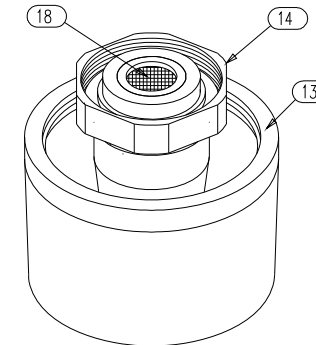

Fig 3

SUPPLY PRESSURES	FLOW LIMITERS
High pressure hot High pressure cold	Grey limiter 6l in hot side Yellow limiter 10l in cold side <b>(As supplied)</b>
High pressure hot Low pressure cold	Grey limiter 6l in hot side Remove limiter
Low pressure hot High pressure cold	Remove limiter Yellow limiter 10l in cold side
Low pressure hot Low pressure cold	Remove both limiters

### Pasteurising system

In order to kill off any bio film growth this range of fittings has a built in cleansing feature that allows the mixed water passages to be flushed with hot water without the need to disassemble the mixer or reset the mixed water temperature.

Owing to the high water temperatures passing through the fitting this operation should only be performed by a competent person using the necessary safety equipment.

# Line Drawings

## H64WMT

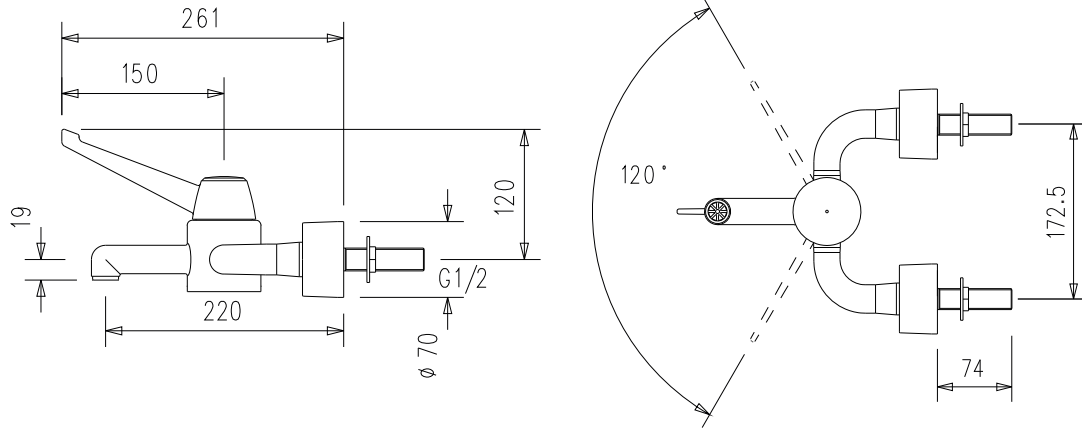

## H64DMT

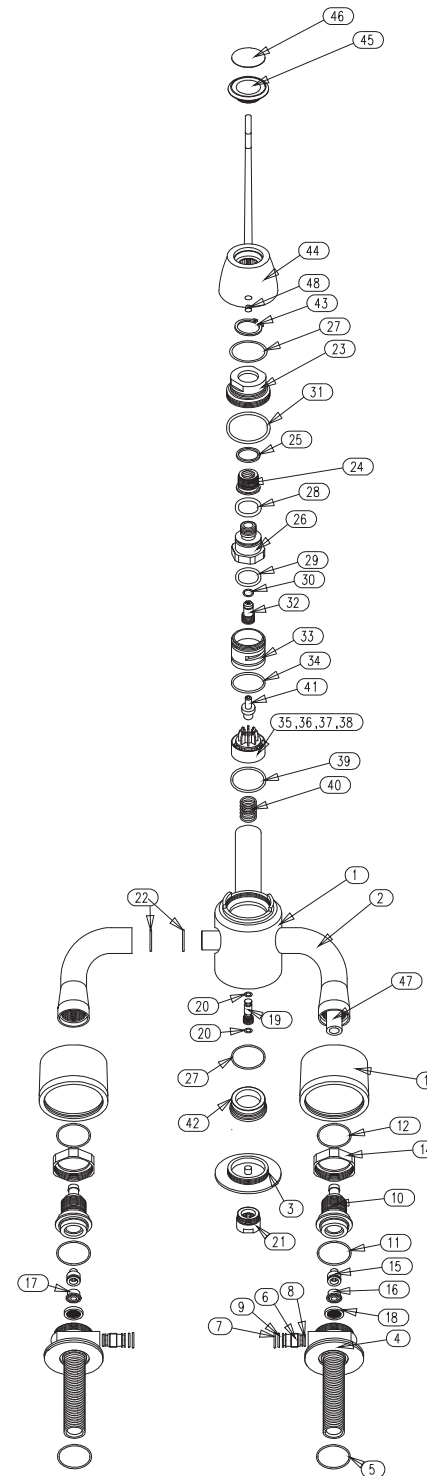
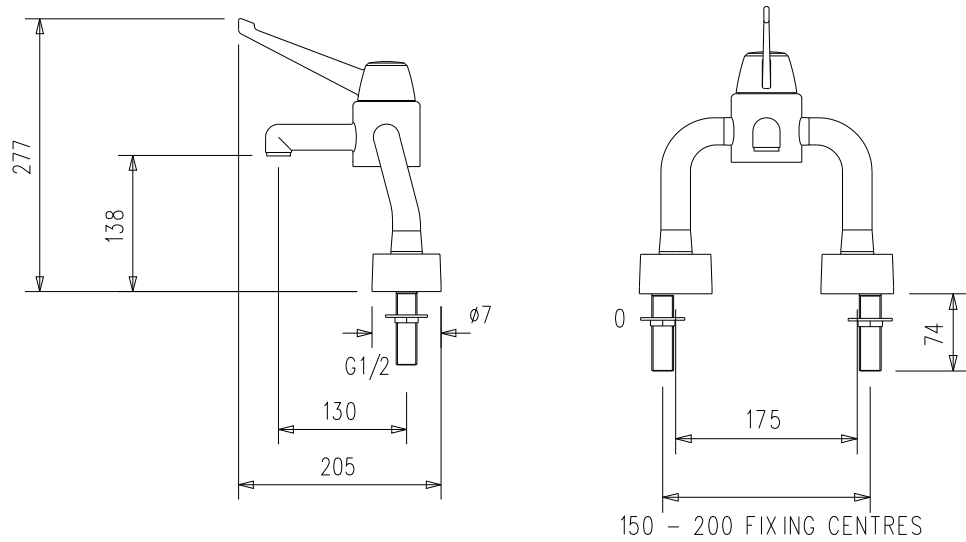

1	BODY
2	LEG
3	BACK COVER
4	INLET BASE
5	O RING
6	ISOLATING PLUG
7	O RING
8	O RING
9	O RING
10	PLASTIC INSERT
11	O RING
12	O RING
13	COVER PLATE
14	SECURING NUT
15	CHECK VALVE
16	FLOW LIMITER
17	FLOW LIMITER
18	FILTER
19	FLUSHING SCREW
20	O RING
21	FLOW STRAIGHTENER
22	O RING
23	HEAD
24	FLOW NUT
25	PTFE WASHER
26	SHUT OFF HEAD
27	O RING
28	O RING
29	O RING
30	O RING
31	O RING
32	ADJUSTING SCREW
33	HALF CARTRIDGE
34	O RING
35	PLASTIC DISTRIBUTOR
36	PLASATIC P I STON
37	SPRING
38	PLASTIC COLLAR
39	O RING
40	RETURN SPRING
41	THERMOSTAT
42	BOTTOM CAP
43	CIRCLIP SS
44	150 HANDLE
45	INDICE HOLDER
46	INDICE
47	HOSE
48	COVER BUTTON

Diagram for reference only

All dimensions in mm.