

## **AFTERCARE INSTRUCTIONS**

Your fitting has a high quality finish and should be treated with care to preserve the visible surfaces.

All surface finishes will wear if not cleaned correctly, the only safe way to clean your mixer is to wipe with a soft damp cloth. Stains can be removed using washing up liquid. All bath cleaning powders and liquids will damage the surface of your fitting, even the non-scratch cleaners.

## **GUARANTEE**

All products are manufactured to the highest standards and a 5 year guarantee covers any defect in manufacture.

**NOTE: The 5-year guarantee on the cartridge is invalidated if damaged by any waterborne debris.**

In the interests of continuous product development we reserve the right to alter specification as necessary

**PRODUCT CODE:**

**PLEASE ENTER YOUR PRODUCT CODE ABOVE IN THE BOX PROVIDED, WHICH WILL BE REQUIRED FOR ANY FUTURE CORRESPONDENCE REGARDING THIS PRODUCT**

**PRODUCT IDENTIFICATION CODE LASER ETCHED ON PRODUCT**

Installer please fill in code here \_\_\_\_\_.

TELEPHONE HELPLINE! +44 (0)844 701 6273

Bristan Group Limited  
Birch Coppice Business Park  
Dordon  
Tamworth  
Staffordshire  
B78 1SG  
UK

A Masco Company  
Website: [www.bristan.com](http://www.bristan.com)  
Telephone: +44 (0) 844 701 6274  
Facsimile: +44 (0) 844 701 6275

(FI PM BF)

(Rev.D5)

# BRISTAN

## **Prism Deck Mounted Bath Filler**

## **Fitting Instructions & Contents List**



Before starting any installation project, consider 'safety' first. Look for the 'safety note' and read the safety advice.

**Please keep these instructions for future reference and request of replacement part**

## WATER PRESSURE

This mixer is suitable for use at all supply pressures. However for optimum use both the hot and cold supplies should be reasonably balanced.

If the fitting is installed at low pressure (tank fed), then the minimum distance from the highest installed position of the shower head to the underside of the cold tank should be 1.8 metres to ensure adequate shower performance.

This mixer should be installed in compliance with the Water Regulations. Where the supplies are unbalanced, i.e. hot water from cylinder tank / cold from the mains, approved check valves must be fitted in the supply pipes.

For further details contact your Local Water Authority.

## CONTENTS

BACKNUT	(1)
GRUB SCREW	(3)
WASHER	(4)
AERATOR	(6)
CARTRIDGE (COLD)	(7)
CARTRIDGE (HOT)	(8)
HEAD ASSEMBLY	(10)

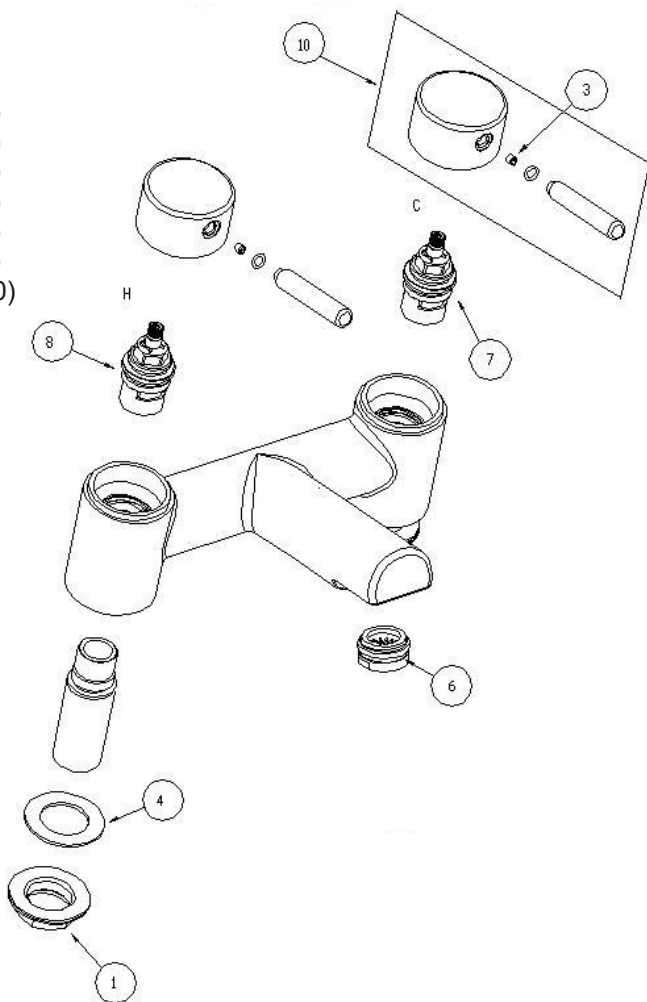

An optional chrome plinth is available with the Prism WHITE range and can be fitted between the product and the basin or bath.

Before starting any installation project please consider:



Prior to drilling into walls, check there are no hidden electrical wires, cables or water supply pipes with the aid of an electronic detector. If you use power tools do not forget:

- Wear eye protection
- Unplug equipment after use

## INSTALLATION

1. Identify all components and check for completeness, particularly before arranging installation.
2. Fit the mixer to the bath using the backnuts and washers, connect the hot and cold water supplies.
3. Connect the hot and cold water supplies.
4. Fully open both valves, letting them run for a few minutes to flush the system.
5. Check all joints and connections for leaks.
6. See over the page for aftercare instructions.

**N.B. Please write the name and product code of your fitting in the spaces provided overleaf. This will ensure a speedier service if you should need to phone the help line.**

## MAINTENANCE

**If the fitting begins to drip:**

1. Turn off the water supply
2. Unscrew handle lever, then loosen grub screw (3) with a 2.5mm hexagon key and pull off head.
3. Remove valve cartridge.
4. Carefully clean seating, rubber washer and ceramic disc.

**NOTE: That there are locating pins on the bottom of the cartridge that fit in holes inside the tap, to ensure it is fitted the right way round.**

5. Replace valve and head and turn on the water supply.
6. Contact our helpline if problem persists.

## PLEASE NOTE:

In the unlikely event you find a part missing, please contact our Customer Service helpline on **0844 701 6273** for immediate dispatch of part