

# BRISTAN

## Installation Instructions & User Guide

Please leave these instructions with the end user

Product Code: OPS BAS C (D2)

### Specifications

#### Dynamic Water Pressure

Min: 0.2 bar Max: 5.0 bar

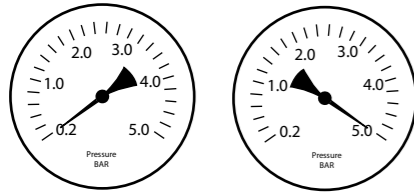

Maximum Static Pressure: 10.0 bar

#### Inlet Water Temperature

##### Cold Water Supply

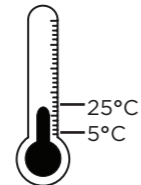

Min: 5°C Max: 25°C

##### Hot Water Supply

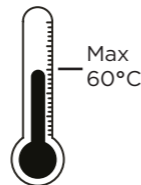

60°C Maximum

#### Inlet Connections

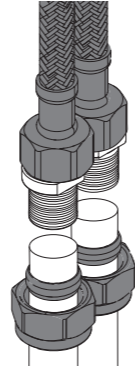

1/2" BSP Flexible Tails

\* Connection adaptors not included

### Tools You'll Need



Flat Head Screwdriver



Adjustable Spanner

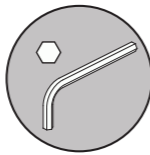

Hexagonal Keys

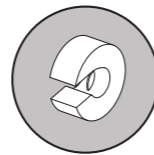

Pipe Cutter

### Prior to Installation

All products manufactured and supplied by Bristan are safe provided they are installed, used correctly and receive regular maintenance in accordance with these instructions.

This product has been tested to the Water Regulations Advisory Scheme (WRAS) and satisfies the requirements of the Water Supply (Water Fittings) Regulations 1999 and current bylaws. For full Installation Requirements & Notes (IRN) please visit [wras.co.uk/directory](http://wras.co.uk/directory).

We recommend isolation valves to be fitted to the inlet water supplies to ensure ease of future maintenance.

Before installing these taps the water supply must be thoroughly flushed in order to remove any swarf, solder etc.

This product must not be modified in any way as this will invalidate the guarantee.

### Pack Contents

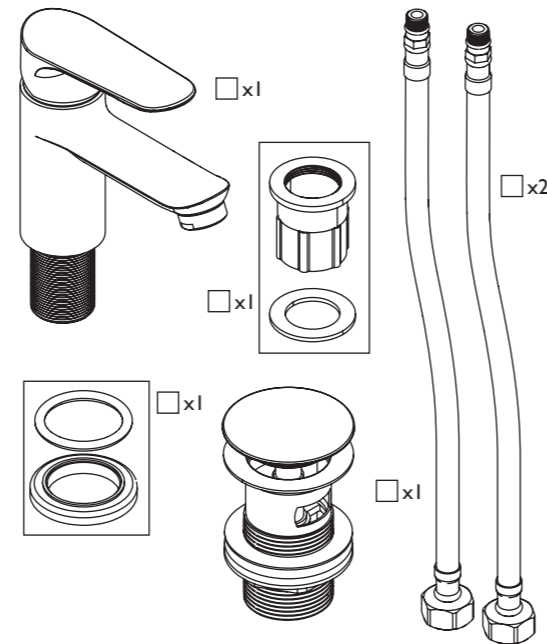

### Spare Parts

To replace any spare parts for your tap, why not scan the QR Code or visit [www.bristan.com](http://www.bristan.com) and search for your product.



### Flexible Tail Positions

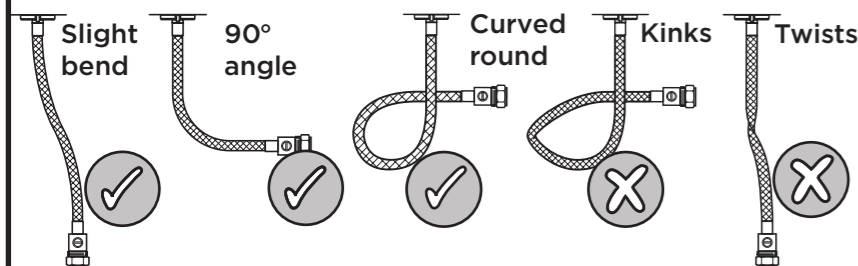

### Installation

1

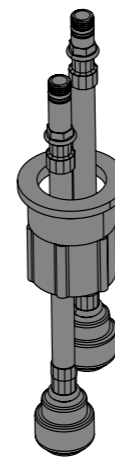
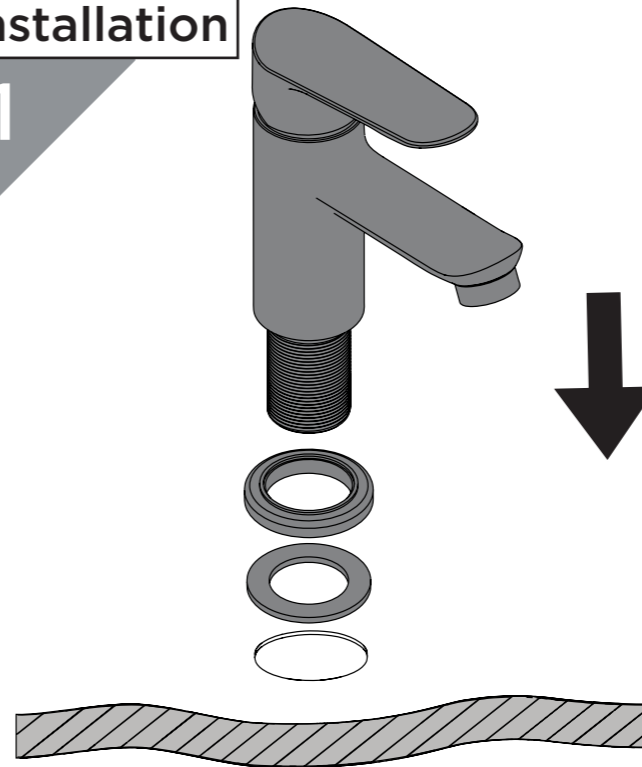

Fit the tap to the basin ensuring the plinth & seal is in place. Screw the tails into the body by hand only. **DO NOT OVERTIGHTEN.**

2

Feed the tap body through the basin hole, ensuring the plinth washer is in place.

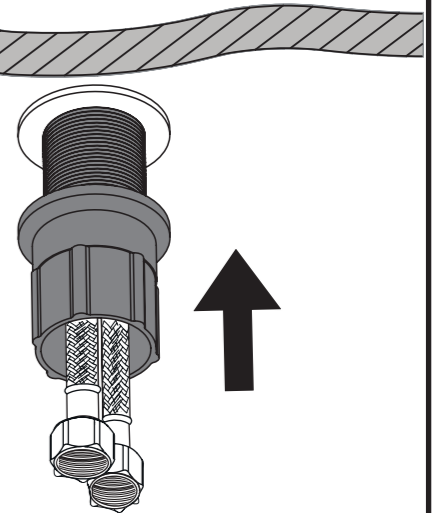

**REMEMBER**  
Hot on the left, cold on the right!

3

Connect the flexible tails to the hot and cold water supplies.

We would recommend that you install flat-faced isolation valves to the water supplies for safety and maintenance purposes

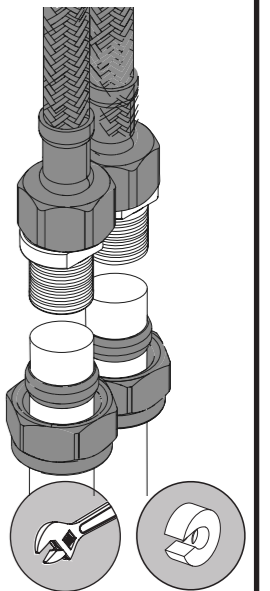

5

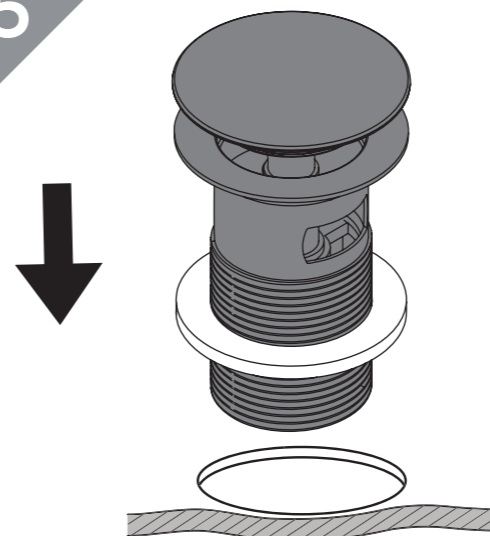

Feed the waste body through the basin, ensuring the rubber washer is in place.

6

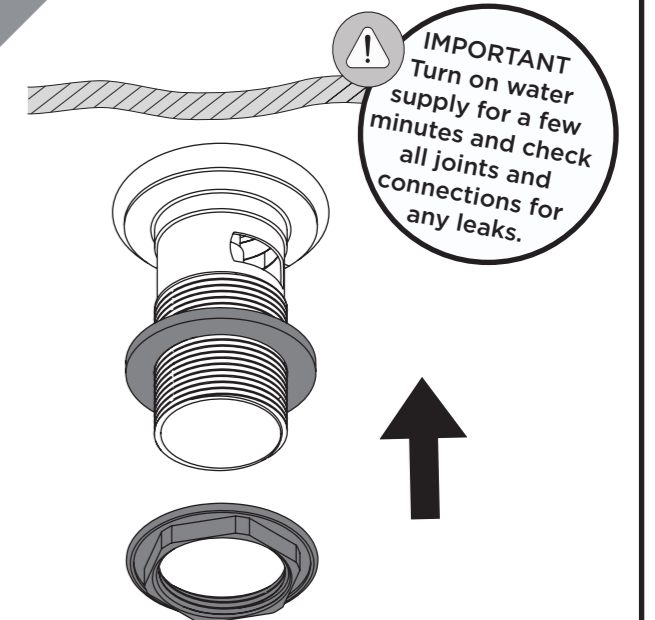

Secure in place using the washer and backnut.

**IMPORTANT**  
Turn on water supply for a few minutes and check all joints and connections for any leaks.

## Operation

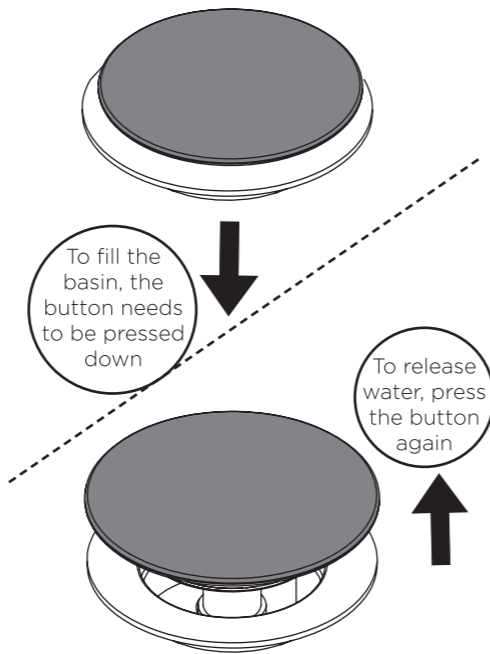
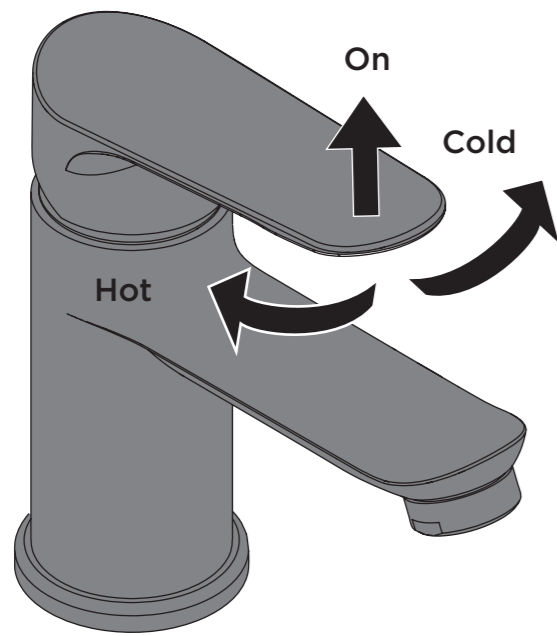

## General Cleaning

Bristan products are made from premium materials, with hand polishing and electroplated finishes.

Your taps or shower should be regularly cleaned with warm water, a mild pH-neutral liquid soap, and polished with a soft cloth. Any residues from soap, toothpaste, shampoos and shower gels can cause blemishes if not rinsed off straight after use.

Household bleaches and cleaners contain harsh chemicals and may damage the surface finish. Avoid using abrasive cloths, scouring pads, scrub sponges, steel wool or anything similar.

Some surfaces such as nickel and pewter may be affected by the dye found in some cloths, so it is also important to avoid hanging cloths on spouts.

## Maintenance - Cartridge Cleaning

1

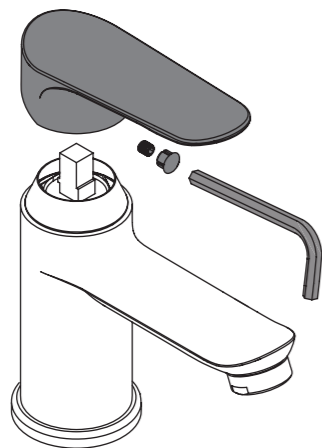
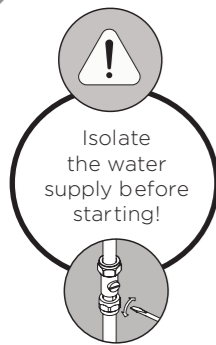

Prise off the cap and undo the grub screw to remove the handle.



2

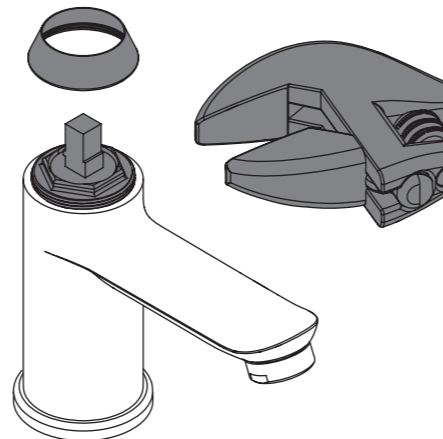

Unscrew the shroud. Undo the cartridge retaining nut to remove the cartridge.



3

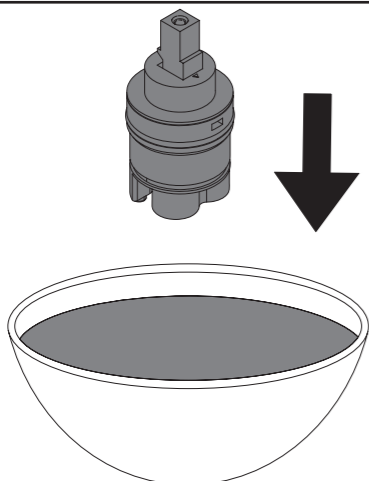

Check any seals and O-Rings for damage; replace the cartridge if necessary. Place the cartridge in a suitable solution and soak until fully de-scaled.

4



Reverse the steps to replace the cartridge and handle.



## Maintenance - Clean/Replace Outlet

1

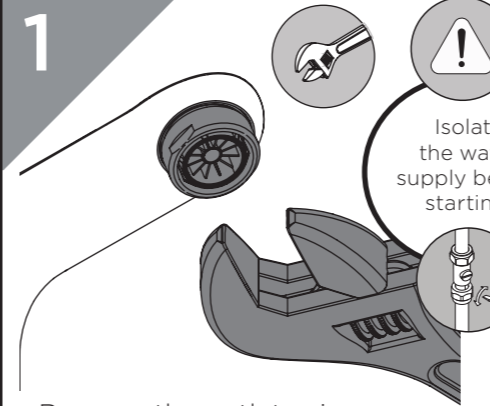

Remove the outlet using a suitable spanner.

2

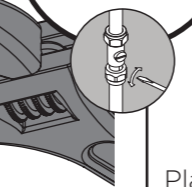
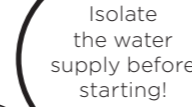

Check any seals for damage; replace if necessary. Place outlet in a suitable solution and soak until fully de-scaled.

3



Reverse the steps to replace the outlet.

## Troubleshooting

Symptom	Cause	Remedy
No flow or low flow rate	Partially closed isolation valve.	Open isolation valve.
	Instantaneous water heater cycles on and off as flow rate or pressure is too low.	Increase water flow rate or pressure through system.
	Head of water is below the minimum distance required.	Refer to specification for minimum distance required.
	Hot or cold water being drawn off elsewhere causing pressure changes or instantaneous boiler temperature changes.	Do not use other water outlets when using the taps.
	Airlock or partial blockage in the supply pipework.	Flush through pipework to ensure removal of debris and any airlocks.
Water dripping from taps	This is normal for a short time after using the taps.	This is caused by residual water tension, the build up of water in the tap body.
	If water continues to drip, possibly due to the ceramic disc valves	Remove valves and clean, refer to 'Maintenance' section before starting any maintenance.
Taps do not turn on	Closed isolation valve.	Open isolation valve.
	Mains water supply turned off.	Turn on mains water supply.

At Bristan, we want to make things as easy as possible for our customers. That's why we offer solid guarantees on all our products, effective from the date of purchase, to give you peace of mind. To start your free guarantee simply scan the QR code and register your product. Alternatively visit [www.bristan.com/register](http://www.bristan.com/register) to register your product via a computer. For full guarantee terms and conditions visit [www.bristan.com/guarantees](http://www.bristan.com/guarantees).



*We Know & We Care*