

1.

Place the sink upside down in the position where it is to be installed, and trace the outline of the sink on the bench top with a pencil.

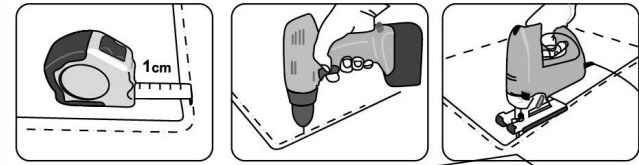

2.

Draw another line 10 mm inside the first line. cut a hole in the bench top following this second, inner, line. (*if the manufacturer has included a pattern in the package, then use the pattern to cut the hole in the bench top).

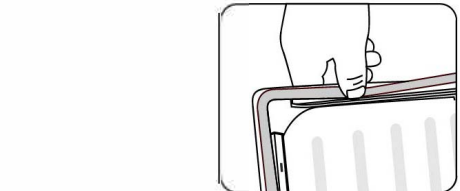

3.

Adhere the rubber bench seal around the under side of the edge of the sink, being careful to lay it smoothly (without ridges).

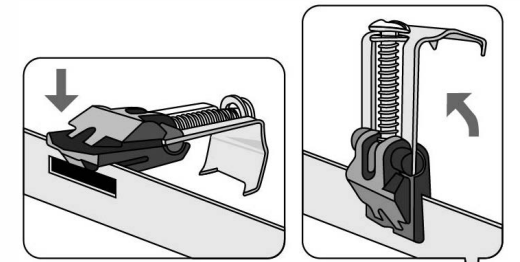

4.

Place the anchor braces vertically and pull them up to lock into their horizontal position.

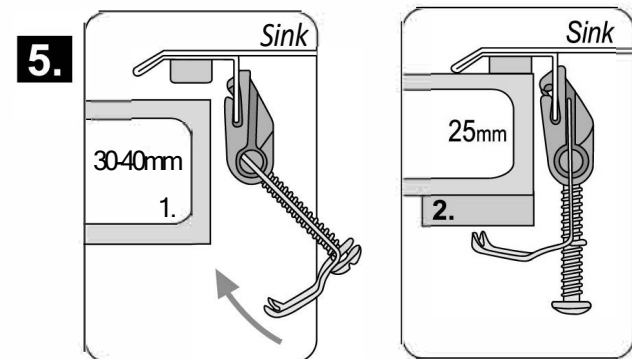

5.

These anchor braces are designed for use with bench tops 30-40 mm thick (1). If your counter top is thinner, insert wooden wedges between the counter top and the braces so as to secure them (2). After placing two at each corner of the sink, place the rest evenly spaced around the perimeter of the sink.

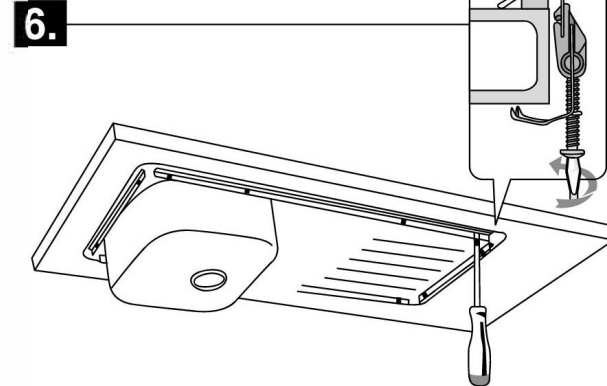

6.

Tighten the screws of the anchor braces (with a hand screwdriver), to secure the sink in place.

SINK UNIT CARE AND MAINTENANCE INSTRUCTIONS

Thank-you for purchasing one our quality Estilo Stainless Steel sinks

Your sink is made of the finest quality stainless steel (CrNi 18/10), DIN 14301 or AISI 304 (suitable for food contact).

Keep your sink looking as good as new by following the care and maintenance instructions.

Instructions

For everyday cleaning of the sink use household detergents suitable for stainless steel. After each use, rinse the sink with warm water then wipe with a soft dry cloth.

- Do not use steel wool to clean your sink
- Do not use chemical "silver cleaners", bleaches, or detergents containing chlorine or any of its derivatives.

Warning!

- If the sink comes into contact with acidic materials. Rinse immediately with plenty of water and wipe with a soft, dry cloth.
- Do not leave rusty objects in contact with the sink. Rust can cause staining, cracking or even permanent damage to the sink surface.
- To avoid staining of the surface do not leave food or other materials with corrosive properties such as juices, salt, vinegar, mustard etc. on the sink for a long time.
- Do not place very hot objects directly on the sink. Place them on a special surface (board) made from wood or plastic, etc.
- Avoid scraping the sink basin or draining board with utensils.
- Avoid dropping heavy or sharp objects onto the sink surface.

 **victorian plumbing.co.uk**



INSTRUCTIONS FOR THE INSTALLATION OF STAINLESS STEEL SINKS