

# AREZZO

## Dual Control Thermostatic Shower Valve

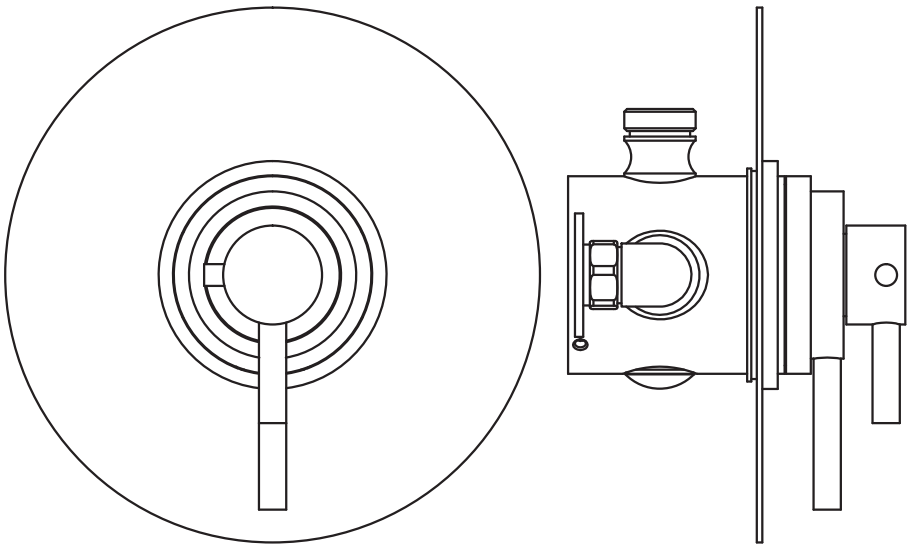

Please follow them carefully and  
leave this manual with end user

# Installation Guide

## Before you begin:

1. **We recommend that this product is installed by a qualified tradesperson,** Victorian Plumbing Ltd. accept no liability for products incorrectly installed, or where the correct testing procedures have not been adhered to, thus resulting in the escape of water and consequential damage.
2. Ensure the incoming mains water supply is switched off prior to commencing the installation.
3. Observe all local plumbing and building codes & regulations.
4. Unpack the product then read these instructions before proceeding. Inspect the product for damage. If any damage is found, contact our Customer Relations team.

## Installation:

1. Determine the fixing position for the valve.
2. Prepare the supply pipes (hot on the left and cold on the right) at the required height with a width of 150mm centres, making sure the ends of the pipes 15mm out from the face of the wall does not exceed.
3. Hot water inlet to be connected with hot supply on the left of the valve, cold water inlet to be connected with cold supply on the right of the valve, which are clearly marked. Make sure that they are correctly connected, otherwise, the thermostatic cartridge will lose its function of controlling temperature and may cause scald.
4. Prior to installation and connecting, make sure the pipes are thoroughly flushed to remove any debris etc. **Attention:** Failure to do this will impair the flow of water.
5. Remove the nuts and olives and place the valve over pipes, mark the position of the back plate and remove. Remove the back plate from the valve by loosening the set screw, position the back plate onto the wall and mark the position of the three holes. Drill suitable length holes at the marked positions. Use supplied plugs and screws to secure the back plate.
6. Slide the cover plates onto the nuts and position each pipe with the cover plate against the wall, slide an olive onto each pipe. Push the valve over each pipe and into the back plate, tighten the two nuts onto hot and cold inlet, and tighten the set screw with supplied Allen key to lock the valve.
7. Push the riser into the top riser outlet, tighten the nut.
8. Then turn on the water supply. Check that there is no leakage. **Attention:** If you choose the concealed model. The valve will come with valve cover plate, not the small nut cover plate. You should make a recess in the wall to house the valve. The depth of the recess should be 53mm to 68mm below the finished wall surface to fit the cover plate correctly.

## Diagram:

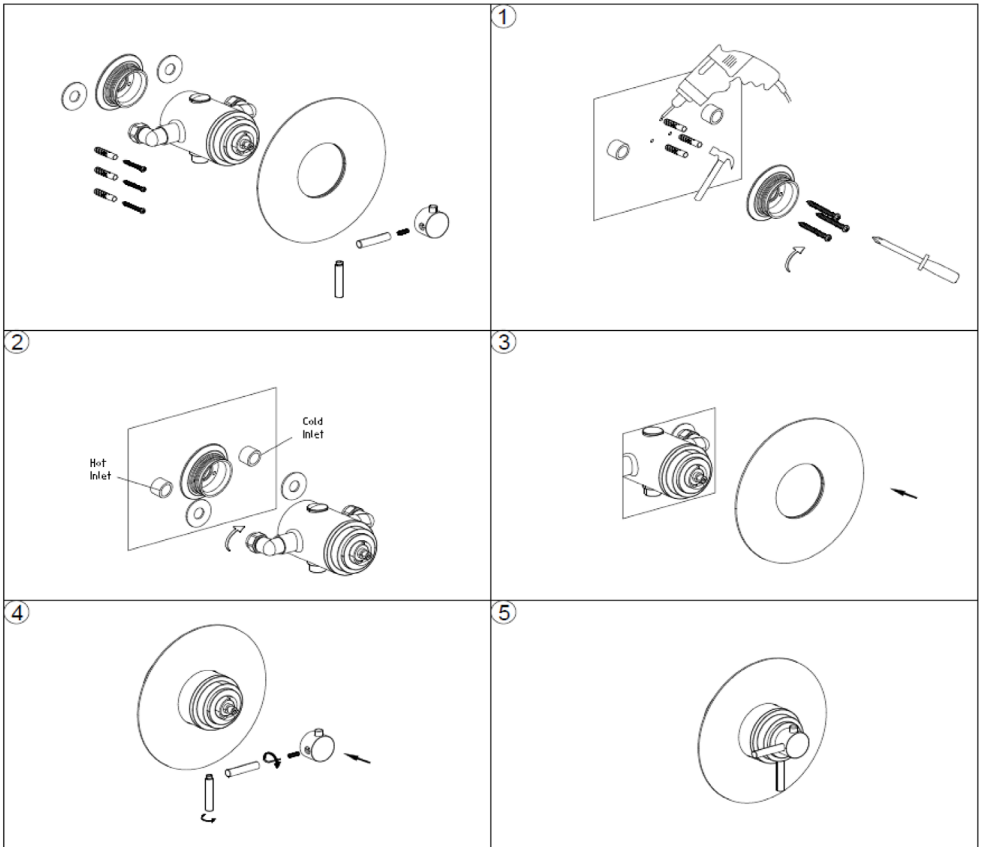

Diagrams are for illustration purposes only. Your thermostatic shower valve may superficially differ from this drawing however the installation guide steps still apply.

# Exploded Diagram

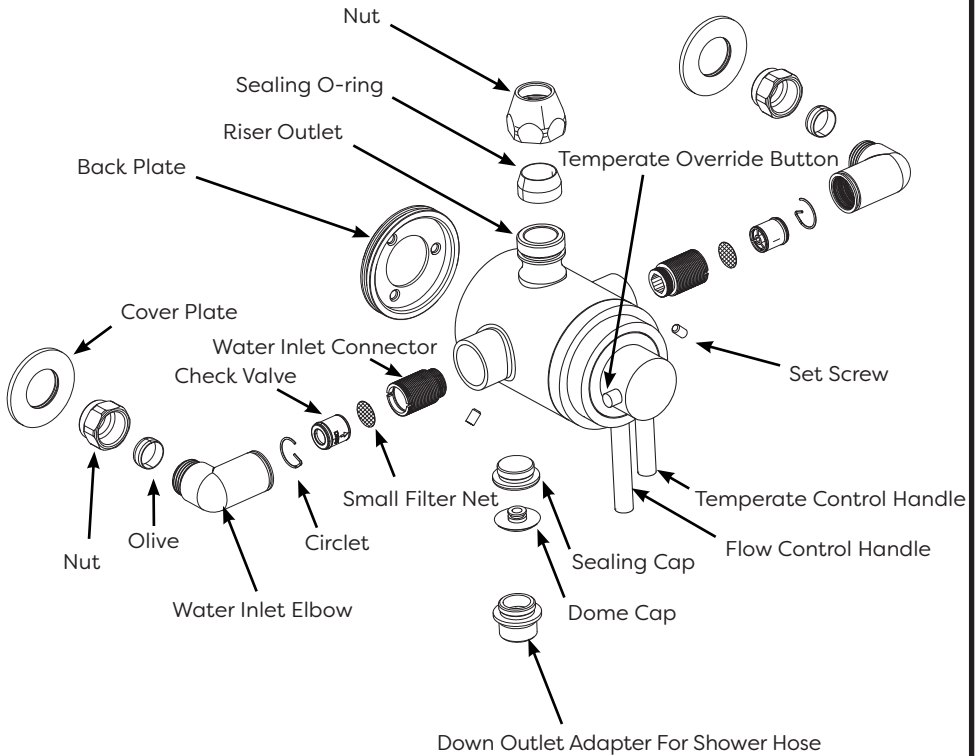

Diagrams are for illustration purposes only. Your thermostatic shower valve may superficially differ from this drawing however the installation guide steps still apply.

## Operation Notice:

1. The work condition for use of this product is cold water 4-29°C, hot water 55-85°C and water pressure 0.5bar - 5bar. To avoid the differential pressure between hot water and cold water, the thermostatic cartridge is preferably under the condition of water pressure 3 bar, hot water 65°C and cold water 15°C.
2. Make sure the shower valve is off when no water comes out of it (especially when nobody resides in the house or during the period of decoration or the absence of water).
3. When the room temperature drops below 0°C, take necessary measures (such measures as keeping shower valve warm and closing windows) to prevent the shower valve from being frozen or even broken (especially when windows kept open for air ventilation while nobody resides in).
4. Do not disassemble the valve unless you are an expert.

## Maintenance:

If the water flow is less than normal and temperature control is imprecise after a period of usage. It is often due to the poor water which blocks the small filter net. The cleaning method: At first, turn off the main valve. Remove the valve by loosening the nuts and set screws. Remove the water inlet elbows, and unscrew the water inlet connector with Allen key. Take out the small filter net and clear it with brush and vinegar. After completion, rinse it and reassemble all the parts back. At last, check the water flow and temperature control.

## Change Top Outlet To Down Outlet:

1. Note: The valve is supplied as the one with top outlet for rigid riser kits. If you need to connect the shower hose, you need to change top outlet to down outlet.
2. Remove the nut and sealing o-ring, you can see the riser outlet on the top of the valve.
3. Use an Allen key to turn the riser outlet out.
4. Remove the dome cap on the bottom of the valve, you can see the sealing cap with hexagon.
5. Use an Allen key to turn the sealing cap out.
6. Install the sealing cap back onto the top of the valve, then cover with the dome cap.
7. The down outlet adapter with 1/2" male thread will be supplied in the inner box. Install the adapter onto the bottom of the valve with an Allen key. Now the valve can be used as down outlet for shower hose.

## Aftercare:

Always clean the surface of shower valve to keep it bright. **Attention:** please do not use inappropriate tools such as sharp brushes, rough sponges, scouring pads or corrosive detergent to clean the shower valve. Please clean the shower valve by wet cloth and soapy water after each time of usage. Then rinse the soap out with clean water and dry with a soft cotton cloth.

# Troubleshooting

| <b>FAULT</b>                                    | <b>POSSIBLE CAUSE</b>   |
|---|---|
| Shower only runs hot or cold after installation | <ol style="list-style-type: none"><li>1. Hot and cold supplies have been plumbed the wrong direction.</li><li>2. Faulty thermostat.</li><li>3. Insufficient water pressure.</li></ol>   |
| Shower does not run hot enough                  | <ol style="list-style-type: none"><li>1. Check the hot water supply temperature.</li><li>2. Maximum temperature needs adjusting, see temperature adjustment.</li><li>3. Blockage in the hot supply.</li></ol>                                     |
| Hot water in cold supply or vice versa          | <ol style="list-style-type: none"><li>1. Check and clean non-return valves.</li><li>2. Check Hot and Cold supplies have not been reversed during installation.</li></ol>  |
| Low or no flow                                  | <ol style="list-style-type: none"><li>1. Possible blockage/debris in the system.</li><li>2. Operating conditions are incorrect.</li><li>3. Valve shut off has been activated due to a pressure drop in either the cold or hot supplies.</li></ol> |
| Leaking when in the off position                | <ol style="list-style-type: none"><li>1. Debris in the flow control cartridge.</li><li>2. Faulty control cartridge.</li></ol>   |
| Fluctuating flow                                | <ol style="list-style-type: none"><li>1. Dynamic inlet pressure are not balanced.</li></ol>   |

# Notes:

[www.victorianplumbing.co.uk](http://www.victorianplumbing.co.uk)