

Technical Details

Schematic Diagram

YW-ARZCS86-CP

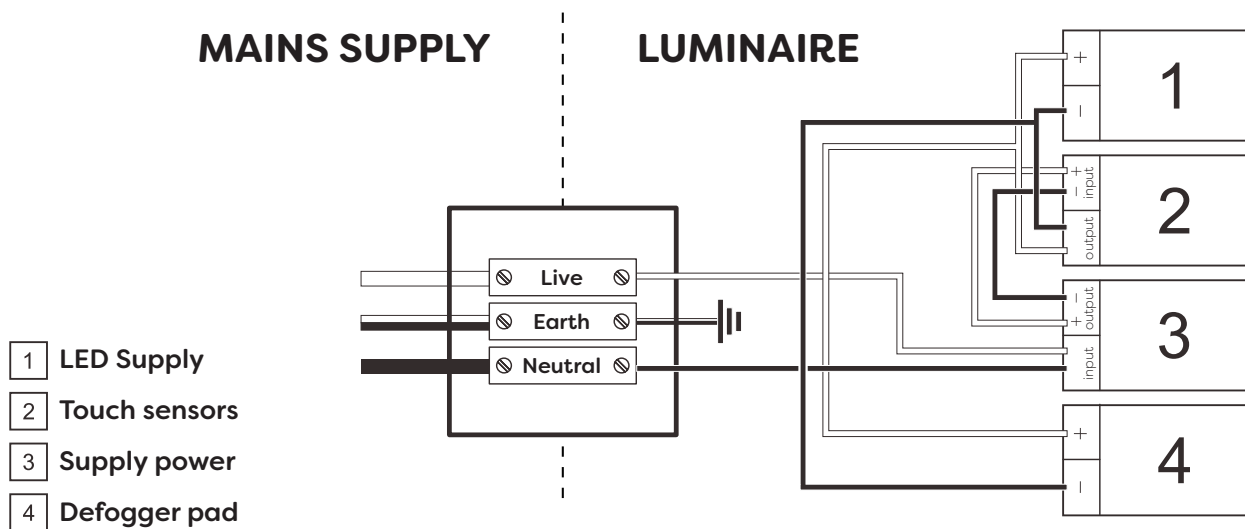

Mirror Weight (kg)	7.50kg
Mirror+Box Weight (kg)	10.00kg
Light Source	LED
Light source average span	50K HOURS
Total Rated Wattage (W)	56W
Lumens (Lm)	2400
Kelvins (K)	3000-6000K

FEATURES
TOUCH SWITCH
DEMISTER
DIMMING
COLOR CHANGE
WIRELESS CHARGING
TIME DISPLAY
CHROME FRAME
METAL SHELF

Technical Details

Data Reference

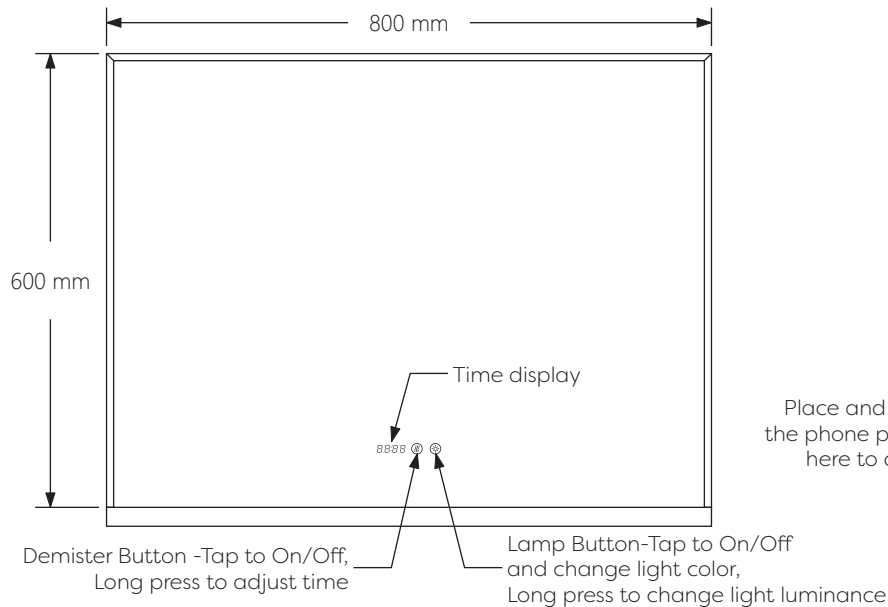

Front view

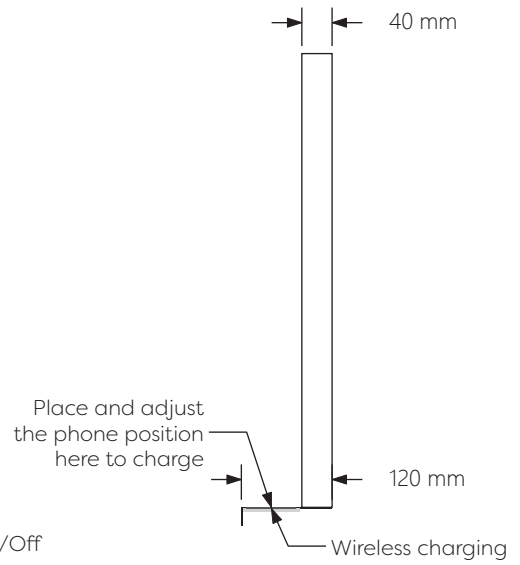

Side view

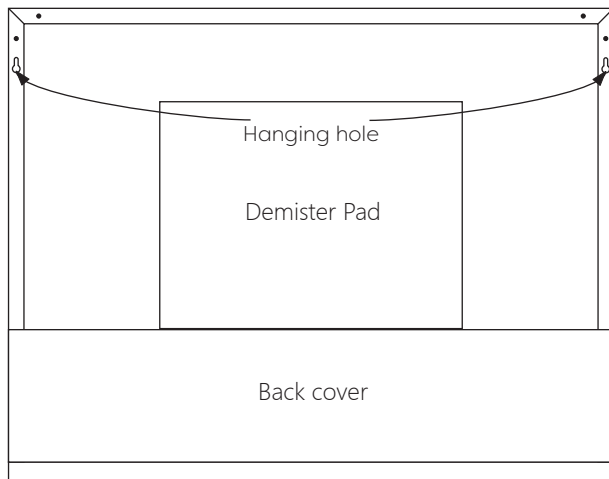

Back view



Bottom view