



INSTALLATION & OPERATING INSTRUCTIONS

Atmos Select

**(3 Way Thermostatic Concentric Mixer Valve
with Riser Rail & Overhead)**

Customer Care - 0845 505 2211

INTRODUCTION

This book contains all the necessary fitting and operating instructions for your MX thermostatic mixer shower.

Please read these instructions carefully. Read through the whole of this book before beginning your installation.

The shower installation **MUST** be carried out by a suitably competent person after reading these instructions.

Care taken during the installation will provide a long and trouble free life from your shower. For the best performance within the specified running pressure range, a minimum flow of 8 liters per minute should be available on both inlets.

This mixer valve is designed to operate on most water systems found up to a maximum of 5 bar running pressure. The valve must not be subjected to water temperatures above 80°C. This mixer is also suitable for thermal storage, unvented systems and pumped gravity systems.

IMPORTANT: Before installing with a gas instantaneous water heater, make sure it is capable of delivering hot water at a minimum switch-on flow rate of 3 liters per minute. At flow rates between 3 and 8 liters per minute, the appliance must be capable of raising the water temperature to a minimum of 52°C.

The water temperature at the inlet to the mixer valve must remain relatively constant when flow rate adjustments are made (refer to the water heater operating manual to confirm compatibility with this mixer shower).

Inlet connections are female $\frac{3}{4}$ BSP threads which can be connected to 15mm or 22mm compression fittings (not included).

SAFETY WARNINGS

Layout and sizing of pipework must be such that when other services are used, pressures at the shower control inlets do not fall below the recommended minimum.

DO NOT choose a position where the shower could become frozen or connect this mixer valve to any form of tap or fitting not recommended by the manufacturer and do not use Boss White or other joining compounds.

The showerhead must be regularly cleaned to remove scale and debris so should be installed to allow this.

Conveniently situated service valves in each inlet supply must be fitted as an independent method of isolating the shower should maintenance or servicing be necessary, these valves should not restrict the flow.

DO NOT operate the shower outside the recommended temperatures and pressures stated in this guide.

As a competent person installing this shower you should ensure that all users are very conversant in its operation before handover and that they understand the need to always test the water temperature with their hand before entering the shower.

Metal surfaces on the hot supply may become hot during operation. Arrange to have the mixer valve regularly serviced by a suitably qualified person.

The British Burns Association recommends 37°C to 37.5°C as a comfortable bathing temperature for children. In premises covered by the Care Standards Act 2000, the valve needs to be set so the maximum mixed water outlet temperature is 41°C.

SITE REQUIREMENTS

The installation must be in accordance with Water Regulations Advisory Service (www.wras.co.uk).

Minimum running water pressure: 0.1 bar, but will operate better at a minimum of 0.5 bar.
Maximum running water pressure: 5 bar, (Static water pressure: 10 bar).

For your shower to perform well you should ensure that the pressure is as specified and a minimum flow of 8 liters per minute is available at both hot and cold inlets.

If a water supply is fed by a gravity then the supply pressure should be verified to ensure the conditions of use are appropriate for the valve.

The pressure at both the hot and cold water supplies to the mixer valve should be the same, and the installer should ensure that the flow is not affected by other taps elsewhere in the house. It is very important that for use in any mains pressure systems an expansion tank and a pressure reducing valve has been fitted to ensure the pressure does not exceed 5 Bar. This should be cleared by the installation engineer before installation.

NOTE: Water Regulations requires the handset to be 'constrained by a fixed or sliding attachment so that it can only discharge water at a point not less than 25mm above the spill over level of the relevant bath, shower tray or other fixed appliance'. A double check valve, or similar, MUST be fitted in the supply pipework to prevent back-flow.

WATER TEMPERATURE REQUIREMENTS

Maximum hot water temperature = 80°C, Recommended maximum = 65°C.
Minimum hot water temperature = 55°C, Maximum cold water temperature = 25°C.

TEMPERATURE ADJUSTMENT RANGE

The mixed water temperature can be adjusted from cold through to hot. There is a safety stop preset at a set temperature of about 38°C. Do not turn the thermostat before installation as this might result in the preset being fitted at the wrong temperature position.

In the event of failure of cold water system, the valve automatically reduces the flow of hot water to prevent scalding. It will only operate again once the flow of cold water has been resumed.

Before proceeding with the installation check all the components in the component list are present.

INSTALLATION

WARNING!

The mixer valve should be fitted only after all the pipework has been installed and ensure no pipes or wires are behind where the screws will be required.

Do not modify or use jointing compounds on any of the pipe fittings. Do not solder fittings near the mixer valve after it has been connected as heat can damage the valves or seals. Always flush the system prior to installing the valve.

Before installing, make sure the mixer valve is kept in a clean place to prevent any rubbish etc, getting into the openings while fitting the pipework.

- The mixer valve is suitable for installation on a solid wall, a stud partition wall, dry lined wall or fixing to a cubicle or panel.
- The water pipes should be securely attached within the wall or panel to prevent pipe movement or water noise after installation. The valve should be securely attached to the wall using the fixing points.
- The mixer valve hot water inlet has a hot next to the inlet and the cold has a cold, the valve will not operate if connected the wrong way.
- The mixer valve is designed to work at the same hot and cold water pressures. If this is not the case a flow controller (disc with small holes) can be fitted to the higher pressure supply to the valve. This is best done by testing each one to find out which gives the best results.
- Remember the mixer valve must be installed in such a position that the maintenance of the TMV and the filters can be done after installation and the commissioning and testing of the TMV can be undertaken.

SITING OF THE MIXER VALVE

Position the mixer valve so that all controls can be comfortably reached while using the shower.

NOTE: Easily accessible suitable service valves (complying with Water Regulations Advisory Service www.wras.co.uk). MUST be fitted as close as practical to the valve, on the hot and cold water supplies to the shower as an independent means of isolating the water supplies should maintenance or servicing be necessary. These valves should not restrict the flow.

The supply pipework can be plumbed from above or below but must finish at the suitable connections, which should be 150mm centers. If installing into a stud partition etc, the pipework and the valve will need support.

Before fitting the mixer valve flush out the pipework in accordance with Water Regulations Advisory Service (www.wras.co.uk).

IMPORTANT

This valve is factory preset so that the control knobs are fitted in the correct location. Do not turn the shafts until you have fitted the handles after completing installation.

These fitting instructions assume you would wish to have the valve in a configuration such that the temperature control is at the bottom and the diverter is at the top. You can fit it in any other configuration you choose but you must make the appropriate amendments to the instructions yourself. Ensure when changing the configuration of the valve the hot and cold inlets are correctly connected as stated on the valve.

SITING OF THE SHOWER

Having established the position of the mixer valve so that all controls can be comfortably reached whilst using the shower, the handset and riser rail should be positioned at the side of the valve and the overhead rail directly above the valve. Make sure any cables and pipework are not behind the required screw holes.

Consult the illustration below to make sure you check from the component list that all the parts for your system are supplied.

Select Valve with Riser Rail & Overhead (Square Style)

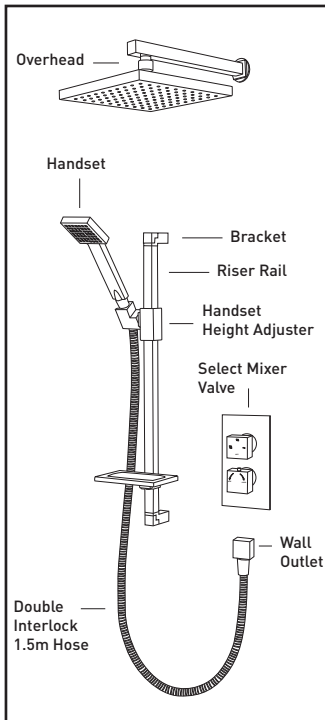

Atmos Select Square

Select Valve with Riser Rail & Overhead (Round Style)

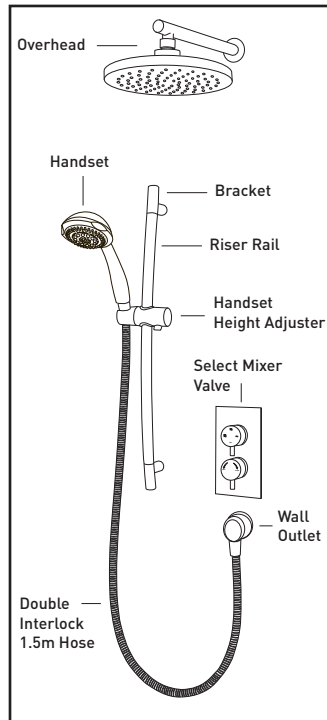

Atmos Select Round

PRESSURE BALANCING

Pressure balancing when the feed water pressure is different between hot and cold feeds.

The thermostatic mixer valve is designed to work best when the feed pressures of both hot and cold water are the same. If there is a difference in pressure it will cause the flow of water through the valve to pulse rather than being a steady flow. This pulsing can be reduced by putting one of the metal disks with holes (Fig1-3) into the higher pressure feed to the valve. This restricts the flow and reduces the pulsing).

To maximise the volume of water through the valve the disk with the most holes should be tried first. If this does not work the others should be tried until a satisfactory result is obtained.

If the water pressures to hot and cold are the same these disks do not need to be used.

NOTE: Do not adjust the centre threaded screw as this is factory set.

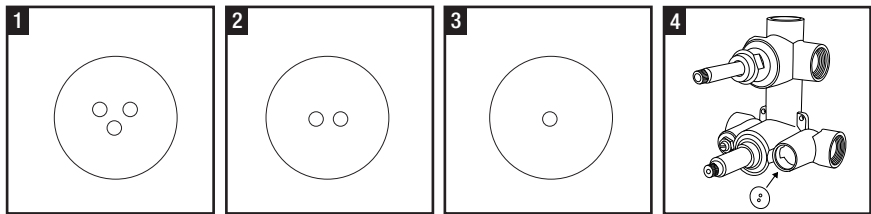

FITTING OF THE MIXER VALVE

1. A rectangular hole between approximately 200mm and 160mm should be large enough to fit the mixer valve. The valve should be fixed to the wall between 75mm and 90mm below the finished surface of the shower (See Fig 5).
2. The supply pipework can be plumbed from above or below but must finish at the suitable connections which should be at approximately 150mm centers (See Fig 6), provision should be made for some adjustment on fitting the valve.
3. Fit a male $\frac{3}{4}$ BSP elbow to 15mm or 22mm compression (not supplied) to both hot and cold inlets and the outlets, apply PTFE tape to seal the threads.

NOTE: It is recommended to apply PTFE tape to all threaded connections (boss white or other sealing compounds are not suitable).

The valve can be used either as a 2 way or a 3 way valve depending on the users preference, and a blanking nut is provided to blank off one outlet when being used as a 2 way valve. When using as a 3 way valve, the third outlet may be used for body jets or other accessories which are not supplied.

You should measure the distance between the outlets on the mixer valve you are fitting to determine the exact distance.

4. At this point you may wish to fit the pipework and the wall arm (See wall arm fitting and wall outlet) prior to any tiling.
5. The valve should be attached firmly between 85mm and 95mm below the finished surface to allow the cover plate to fit neatly, using the two fixing holes on the

valve. Position the valve centrally between the feed pipes and mark the screw positions, drill and plug the wall.

NOTE: Make sure the mixer valve is kept in a clean place to prevent rubbish etc, getting into the openings while fitting the pipework. Tiling behind the trim plate must leave sufficient access to the valve for servicing later.

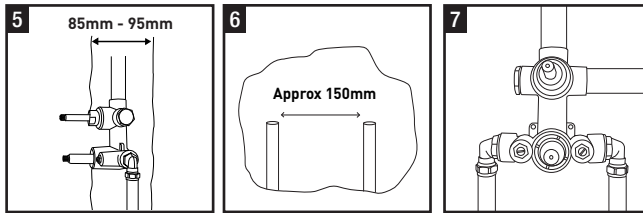

6. Position the mixer valve onto the hot and cold water feed pipes and tighten the compression nuts (See Fig 7). Hold the mixer valve in place and secure to the wall with screws. Make sure the mixer valve hot feed is connected to the inlet marked hot and the cold inlet marked cold. The valve will not work correctly if connected the wrong way.
7. Screw the two chrome cover sleeves onto both the control shafts (See Fig 8).
8. Pipes must be fitted from the $\frac{3}{4}$ BSP female outlets of the mixer valve to the location at which you wish to position the wall outlet, overhead arm or other fittings. These pipes must end in $\frac{1}{2}$ female connection so the wall outlet and overhead arm can be fitted. If fitting as a 2 way valve, the unused outlet must be blanked off using the $\frac{3}{4}$ BSP blank plug supplied.
9. Once the mixer valve and wall outlet are fitted, prior to fitting the trim plate ensure all connections are watertight. This can be done by reconnecting the water supplies and check all connections. To do this you must fit the diverter handle in the correct position so that 'off' is at the bottom. After pressuring the system and checking no leaks are present turn the handle to all other positions, checking each time that there is no leak. Return the handle to its original position and remove.
10. The trim plate is fitted by pushing it onto the mixer valve until flush with the tiles (See Fig 9).

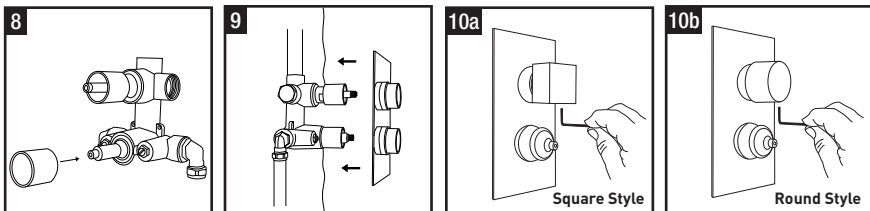

NOTE: Before assembling the valve controls identify all the parts and check that both the red markings on the control shaft of the thermostatic control are inline.

11. Fit the on/off control knob onto the diverter (the top shaft with the 'off' at the bottom), push fully onto the shaft. Hold firmly in position and tighten the grub screw with allen key supplied (See Fig 10a/b).
12. Next fit the stop ring into the lower shaft assembly with the notch at the bottom (See Fig 11).

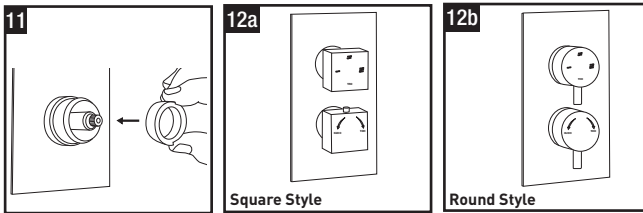

13. Fit the temperature control knob onto the lower shaft with the override button at the top. Hold the control knob firmly in position and tighten the grub screw with allen key supplied.

NOTE: Test water temperature by turning the flow control knob clockwise. Allow the water to stabilise, this should be at approximately 38°C. Use a thermometer to accurately measure this temperature. If the temperature is not 38°C you need to adjust the stop ring so it is in the correct position (See commissioning).

14. Fit chrome caps to the grub screw hole for square style and fit control levers to circular style to complete valve installation (See Fig 12a/b).

RISER RAIL FITTING FOR Square Style

1. Having established the position of the riser rail so that the showerhead can be comfortably reached whilst using the shower, make sure any cables and pipework are not behind the screw holes (See Fig 19).
2. Remove caps for the riser rail wall brackets, mark the position of the holes and drill, plug and screw to fit the two wall brackets (See Fig 20). Fix lower bracket to wall.
3. With the handset height adjuster on the left hand side, fit the hose retaining ring and then the soap dish onto the bottom of the rail assembly (See Fig 15 & 16). Replace the rail assembly onto lower bracket. Fit top bracket to rail and screw to wall and replace both end caps.

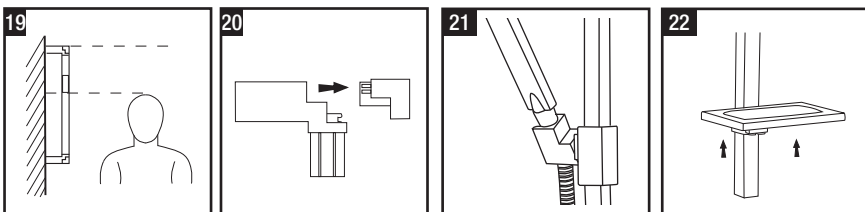

RISER RAIL FITTING FOR Round Style

1. Having established the position of the riser rail so that the showerhead can be comfortably reached whilst using the shower, make sure any cables and pipework are not behind the screw holes (See Fig 17).
2. Remove end bracket cover, to explore fitting point from upper of lower brackets. (See Fig 18).
3. Drill and plug the wall and fix the lower bracket without the rail locator notch. Fit rail to lower bracket. Place the remaining bracket on top of the rail making sure the slot in the rail is located into the bracket notch. Ensure the hole position is vertically aligned and mark the wall. Remove the rail then drill and plug the wall.
4. With the handset height adjuster on the left hand side, fit the hose retaining ring onto the bottom of the rail assembly. (See Fig 19 & 20).
5. Replace the rail assembly through the lower bracket refit the top bracket ensure the slot or indent in the rail is located into the bracket notch and fix to the wall.

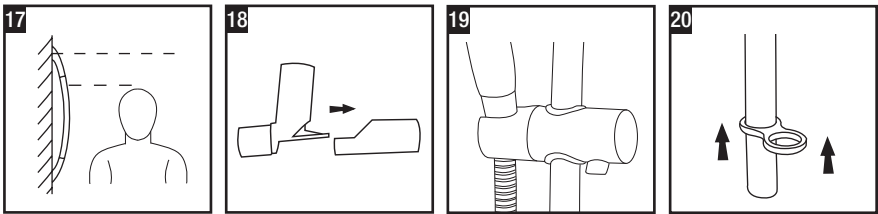

FITTING THE DOUBLE INTERLOCK HOSE & HANDSET

1. Connect one end of the double interlock hose to the outlet on the wall outlet, (See Fig 21a & 21b) making sure that the sealing washer is in place.
2. Pass the double interlock hose through the hose retaining ring the screw onto the handset using the washer (See Fig 22a & 22b), carry out a leak test.
3. MX provide an eco flow controller with every handset they sell. This reduces the flow of water at high water pressures. If you require, fit between the handset & the hose.

NOTE: It is the conical end of the double interlock hose which grips into the handset height adjuster. The handset will not fit in the height adjuster without the double interlock hose attached.

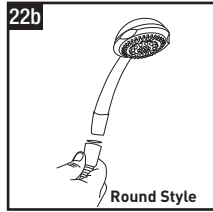
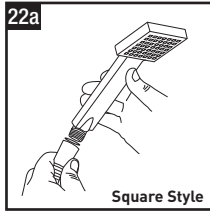
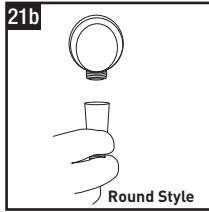
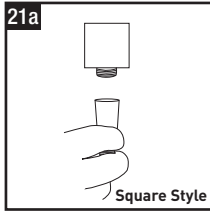

WALL ARM FITTING

1. Establish position of wall arm to suit users requirements (See Fig 23).
2. When fitting the wall arm drill a suitable 19mm hole through the wall, you may require a suitable piece of wood to give the arm support behind the tiles or plasterboard.
3. Remove fittings and nuts from end of arm and push arm through wall, re-fit washer and nut.
4. Connect wall arm to the pipework installed from the valve.
5. When attaching the fixed showerhead make sure the sealing washer is in place and screw tight to seal the joint (See Fig 24a & 24b) again a flow controller can be fitted if required.
6. Pressure test to make sure there are no leaks before tiling.

NOTE: The fitting of these items should be carried out by a competent person.

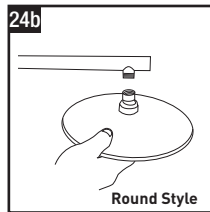
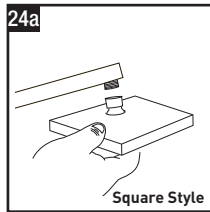
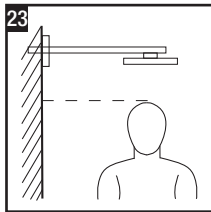

COMMISSIONING AND ANNUAL MAINTENANCE TESTING

On commissioning carry out the following checks and tests:

- All the pipe work has been flushed through before fitting the valve
- The valve you have purchased matches the installation
- The supply pressures and temperatures are checked and all are in the range specified in the instructions
- The isolation valves and strainers are fitted and clean of any unwanted material and do not restrict flow

Ensure both isolation valves are fully open. Turn the temperature control to cold and turn the flow on. Check the temperature is at the required minimum. Rotate the temperature controller gradually until it reaches the preset stop let it flow until the hot water has reached the valve and the temperature has stabilized. Check the temperature is $38^{\circ}\text{C} \pm 2^{\circ}\text{C}$. This is the valves factory preset.

NOTE: If your temperature is not 38°C the following operation should only be carried out by a competent TMV engineer. To adjust the temperature at the stop to 38°C , this can be achieved by the following;

Firstly position the temperature control knob at the stop. Remove the temperature control knob by undoing the grub screw. Then turning the splined shaft clockwise to decrease the temperature (colder) or anti-clockwise to increase the temperature (hotter) when you have achieved a temperature of 38°C , re-assemble the stop ring and the temperature control knob.

Override the stop by pressing the button and rotate to maximum being careful to avoid scalding. Measure the temperature.

The valve should then be checked to confirm the water isolation performs correctly. Run the valve at the 38°C stop position. Check the water temperature. Turn off the feed of cold water using the isolation valve. The water flow should fall to a very low flow, (possibly only a drip) after a few seconds. Collect the water after 5 seconds and 30 seconds and measure the temperature it should be below $46^{\circ}\text{C} \pm 2^{\circ}\text{C}$. Turn on the cold water again and it should return after a few seconds to stabilise to $38^{\circ}\text{C} \pm 2^{\circ}\text{C}$.

Adjustment of the temperature settings is only to be carried out by a competent TMV engineer as it is a technically difficult operation in which the valve can be easily broken. It can be done by removing the handle on the temperature controller, (noting carefully the assembly of the components), rotating the internal stops a few degrees in the required direction and then reassembling. All the commissioning checks should be redone again to ensure it now meets the required specification before using the shower.

FAULT FINDING GUIDE

Probably the most common faults are when the hot and cold supplies are fitted the wrong way or that there is no flow of water (possibly because a valve is closed or the filters have become blocked during installation). Before starting the following checks, it is recommended you check hot and cold water are flowing to the valve and that the hot water is connected to the side which says hot.

| <u>PROBLEM</u> | <u>POSSIBLE CAUSE</u> | <u>SUGGESTED ACTION</u> |
|---|---|---|
| 1. Water too hot. | A Temperature control is not correctly commissioned. | Adjust the temperature control - this is only a job for a suitably qualified person. |
| | B Not enough cold water flowing through shower. | Turn temperature control clockwise. |
| | C Increase in the ambient cold water temperature. | Turn temperature control clockwise. |
| | D Cold water supply blocked. | Turn off shower and consult a competent plumber. |
| | E High volume of cold water drawn off elsewhere. | Reduce the simultaneous demand from the supply. |
| | F Cold water filter blocked. | Remove valve and clean filters. |
| 2. Water too cold. | A Temperature control is not correctly commissioned. | Adjust temperature control. |
| | B Not enough hot water flowing through shower. | Turn the temperature control anti-clockwise. |
| | C Decrease in the ambient cold water temperature. | Turn the temperature control anti-clockwise. |
| | D Hot water filter blocked. | Remove valve and clean filters on the inlet. |
| | E Insufficient hot water supplies from the heating system. | Make sure the hot water is available by trying a hot water tap elsewhere in the house. |
| | F Hot water supply blocked or restricted. | Turn off shower and consult a suitably competent plumber. |
| G Pressure in excess of max recommended. | Fit pressure reducing valve. | |

| <u>PROBLEM</u> | <u>POSSIBLE CAUSE</u> | <u>SUGGESTED ACTION</u> |
|---|--|---|
| 3. Water does not flow or shower pattern collapses when another outlet is turned on. | A Water supplies cut off | Check elsewhere in house and if necessary contact local water company. |
| | B Blockage in pipework. | Turn off shower and consult a suitably competent plumber. |
| | C Valve filters blocked by debris in water supply. | Remove valve and clean filters. |
| | D Showerhead blocked. | Clean Showerhead. |
| 4. Shower controls noisy whilst in use. | E System not capable of supplying multiple outlet at the same time. | Reduce simultaneous demand. Check stop/service valves are fully open. Check if enough water pressure. |
| | A Running pressure in excess of maximum recommended. | Fit reducing disc to outlet of valve. |
| 5. Shower will not shut off. | A Flow control cartridge worn. | Renew flow control cartridge see parts list. |

COMPONENTS LIST

Atmos Select Square Style

| Description | Quantity |
|-----------------------------|-----------------|
| Brass Select Mixer Valve | 1 |
| Blanking Nut | 1 |
| Filter Washer | 2 |
| Mixer Valve Screw Pack | 1 |
| Allen key | 1 |
| Trim plate Valve Cover | 1 |
| Pressure Balance Kit (15mm) | 1 |
| Flow Restrictor + Washer | 1 |
| Square Wall Outlet | 1 |
| Cube Riser Rail | 1 |
| Riser Rail Fixing Bracket | 2 |
| Square Height Adjuster | 1 |
| Riser Rail Screw Pack | 1 |
| Single Mode Handset | 1 |
| Square Hose Retaining Ring | 1 |
| 1.5m Hose + Washers | 1 |
| Square Soap Dish | 1 |
| Square Overhead | 1 |
| Overhead Square Arm | 1 |
| Fitting Instructions | 1 |
| TMV Registration Card | 1 |
| Flow Controller | 2 |

Atmos Select Round Style

| Description | Quantity |
|------------------------------|-----------------|
| Brass Select Mixer Valve | 1 |
| Blanking Nut | 1 |
| Filter Washer | 2 |
| Mixer Valve Screw Pack | 1 |
| Allen key | 1 |
| Trim plate Valve Cover | 1 |
| Pressure Balance Kit (15mm) | 1 |
| Flow Restrictor + Washer | 1 |
| Circular Wall Outlet | 1 |
| Fusion Riser Rail | 1 |
| Riser Rail Fixing Bracket | 2 |
| Push-Button Height Adjuster | 1 |
| Riser Rail Screw Pack | 1 |
| Multi Mode Handset | 1 |
| Circular Hose Retaining Ring | 1 |
| 1.5m Hose + Washers | 1 |
| Circular Overhead | 1 |
| Overhead Circular Arm | 1 |
| Fitting Instructions | 1 |
| TMV Registration Card | 1 |
| Flow Controller | 2 |

ACCESSORIES KIT SPARE PARTS

Square Style

- | | |
|-----------------------------|-----|
| 1. Cube Single Showerhead | ZLR |
| 2. 1.50m Hose | ZLM |
| 3. Cube Riser Rail Complete | ZKC |
| 4. Valve Only 36HMM | ZLF |
| 5. Fixed Overhead Square | ZLT |

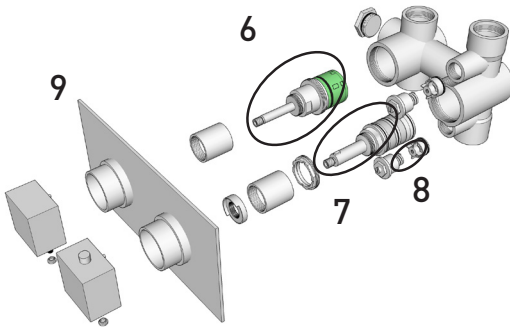

VALVE SPARE PARTS LIST

- | | |
|---------------------------------|-----|
| 6. Flow Cartridge with Diverter | ZKA |
| 7. Thermostatic Cartridge | ZKN |
| 8. Non Return Valve | ZJS |
| 9. Rectangular Cover Plate | ZJX |

ACCESSORIES KIT SPARE PARTS

Round Style

- | | |
|-------------------------------|-----|
| 1. Slice 6 Mode Showerhead | ZLQ |
| 2. 1.50m Hose | ZLM |
| 3. Fusion Riser Rail Complete | ZKB |
| 4. Valve Only 36HMM | ZLE |
| 5. Fixed Overhead Round | ZLS |

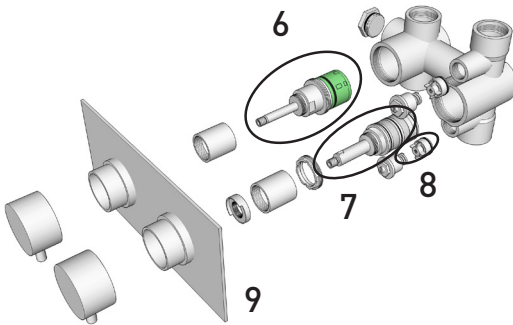

VALVE SPARE PARTS LIST

- | | |
|---------------------------------|-----|
| 6. Flow Cartridge with Diverter | ZKA |
| 7. Thermostatic Cartridge | ZKN |
| 8. Non Return Valve | ZJS |
| 9. Rectangular Cover Plate | ZJX |

MX GROUP GUARANTEE

Marleton Cross Limited and its subsidiaries (“MX Group”) hope you are satisfied with your purchase and in the unlikely event that you encounter a problem which is caused exclusively by MX Group manufactured product (the “product”) we will take responsibility on the terms set out here.

We guarantee this product, in the following terms, for a period of 5 years, from the date of delivery, against mechanical defects arising from faulty materials or from poor workmanship, providing the product has been:

- Installed in accordance with the fitting instructions (oral or written), technical information supplied and/or associated advertising; and
- Used strictly in accordance with all our instructions (oral or written), associated advertising and technical data (including product information and specification sheets) current at the time of purchase and good working practice.

MX Group at their discretion undertake to repair or replace without charge, provided the product has been properly installed, maintained and operated in accordance with the operating instructions.

This product must not be modified, repaired or taken apart except by a person authorised by MX Group.

What is not covered by this guarantee:

1. Any product found to be defective during this period, as the result of misuse or damage, or the effects of scaling, will not be covered by this guarantee.
2. Breakdown due to:
 - Use other than domestic use by you or your resident family
 - Wilful act or neglect
 - Any malfunction resulting from the incorrect use or quality of water or incorrect setting of controls; and
 - Faulty installation.
3. Repair costs for damage caused by foreign objects of substances or the inappropriate use of jointing compounds or blow torches.
4. Total loss of the product due to non-availability of parts or other reason, (MX Group will maintain stocks of spare parts for repair for at least 5 years from end of product line to cover this guarantee).
5. Compensations for loss of use of the product or consequential loss of any kind.
6. Call out charges where no fault has been found with the appliance.

7. The cost of repair or replacement of pressure relief devices, showerheads, hoses, riser rails and/or wall bracket, tiles, cubicles or any other parts installed at the same time.
8. The cost of routine maintenance, adjustments, overhaul modifications or loss or damage arising there from, including the cost of repairing damage, breakdown, malfunction caused by corrosion, furring, pipe scaling, limescale, system debris or frost.
9. Units purchased and installed other than in the United Kingdom.

LIMITATIONS

1. This guarantee lasts for a single continuous period of 5 years from the date of delivery by MX Group to you the customer.
2. This guarantee is personal to the original purchaser of the product and is not transferable.
3. Original proof of purchase(s) must be shown for any claim under this guarantee.
4. This guarantee does not cover any products that have been modified, altered or transformed in any way.
5. This guarantee applies to an original installation in accordance to our fitting instructions and does not cover previously installed products (showroom displays etc) or products that have been moved from their original installation position for any reason.
6. This guarantee applies only to manufacturing or material defects. It does not apply to normal wear and tear, accidental damage, inappropriate use (including inappropriate cleaning) or other events outside the manufacturer's control.
7. This guarantee applies only to the product itself and any liability on behalf of MX Group is limited to the cost of the product.
8. If a product is deemed to be of faulty manufacture MX Group will at their discretion replace or repair the product. Any related consequential loss or damage is excluded.
9. No claim will be accepted if a product is installed with a fault (ours or otherwise) that would have been clearly evident before installation.
10. We make no representations, and exclude any and all liability, in respect of any third party products or services supplied by way of extensions to this guarantee.

LIABILITY

1. Except as required or agreed by us, you will not in any circumstances return any of the product to us, and where the property in any of the goods returned to us has passed to you, they will nevertheless remain your property and at your risk unless we have agreed otherwise in writing before their return.
2. Except as stated above, we will not be liable for any direct, consequential or other loss, damage or injury suffered or incurred by you, and you will indemnify us fully against any claims made by third parties, in respect of the goods or otherwise arising from the contract.
3. Nothing contained in the contract will be treated as excluding or restricting any liability on our part for death or personal injury resulting from our negligence.
4. Except as stated above, and to the fullest extent permitted by law, all conditions, warranties and representations, whether express or implied, statutory or otherwise in relation to the product (other than such as relate to title to the product) are excluded.
5. You acknowledge that our prices for the goods reflect these Terms and Conditions, and accordingly that you accept the above limitations on and exclusions of liability in exchange for those prices.
6. When providing information to MX Group you understand that you are doing this subject to our terms and other policies (including data protection) we have in place from time to time, copies of which are available on our website **www.mx-group.com** or on request as per MX Group contact details given herein.
7. This guarantee does not affect your statutory rights.

MX GROUP GUARANTEE SERVICE POLICY

In the event of you needing to contact the MX Group Customer Care Department, the following procedure should be followed:

- 1.** Before telephoning on **0845 505 2211 the MX Group Customer Care Department** you should ensure you have the model number (printed on the valve) and date and proof of purchase your contact details and the postcode where the unit is installed.
- 2.** The MX Group Customer Care Department will be able to tell you whether the fault can be simply rectified by the provision of a replacement part or arrange an on site visit by a Qualified Service Engineer.
- 3.** If a service call is required it will be booked and the date of the call confirmed. You or a representative (over the age of 18 years) must be present during the entire engineers visit. The engineer will not be able to repair or replace or advise on parts or products not supplied as part of the product.
- 4.** A charge will be made in the event of a service call aborted by you, but not by us, or where a call under the terms of guarantee has been booked and failure is not related to product supplied by MX Group (i.e Scaling and furring, incorrect water pressure, or other plumbing problem unrelated to the normal function of the products).
- 5.** If the product is no longer covered by the guarantee, a charge will be made for the site visit and for any parts supplied.
- 6.** Service charges are based on the account being settled when the work is complete. The engineer will request payment. If this is not made on the day or settled within ten working days, and administration charge will be added.

SPARE PARTS

In the event that parts or maintenance is needed outside the guarantee MX will endeavour to help with this. Spare parts codes are given in the fitting instructions. By calling the **Customer Care Department on 0845 505 2211** with the part number, they will be able to quote you to supply these parts, usually via our spare parts distributor.

Marleton Cross Limited Trading as The MX Group,

Alpha Close, Delta Drive, Tewkesbury Industrial Estate, Tewkesbury, Glos. GL20 8JF.

www.mx-group.com email: mixervalves@mx-group.com

Customer Care: 0845 505 2211

6752B 08_13_LH