

# HERITAGE<sup>®</sup>

## BATHROOMS

Basin Waste



Please keep these instructions for future reference and request of replacement parts

## Contents

When you buy a Heritage product, you can be confident that it not only features a beautiful, distinctive, classic design, but that it has also been made to the very highest quality standards.

To ensure that it works to its full potential, it needs to be fitted correctly.

These fitting instructions have been created to give you all of the information you need and, if you need any further help, please do not hesitate to give us a call on **0844 701 8503**.

Important Safety Information

Installation

Maintenance

Guarantee

Notes

## Safety Note

- Please read these instructions & retain for future use. All products manufactured & supplied by Heritage are safe provided they are installed correctly, used correctly and receive regular maintenance in accordance with these instructions.
- **If you are in any doubt about your ability to install this product safely you must employ the services of an experienced qualified plumber.**



Before starting any installation project please consider the following:

- Prior to drilling into walls, check there are no hidden electrical wires or cables or water supply pipes with the aid of an electrical detector.
- If you use power tools do not forget:
  - Wear eye protection.
  - Unplug equipment after use.
- This product must not be modified in any way as this will invalidate the guarantee.
- These fittings need to be installed in accordance with and meet the requirements of the Water Supply (Water Fittings) Regulations 1999 and Scottish Byelaws 2004.

## Installation

### Installation

1. Identify all components are present prior to installation.
2. Fit the waste body (4) and foam washer (5) into the basin.
3. Fit the rubber washer (6) underneath the basin as shown in the diagram, then secure by tightening the backnut (7).

Use a pure silicon sealant where necessary.

4. Fit the waste plate (3) to the waste body and secure with the screw (2) provided.
5. Check all joints and connections for leaks.

## Maintenance

All surface finishes will wear if not cleaned correctly, the only safe way to clean your product is to wipe with a soft damp cloth. Stains can be removed using washing up liquid.

### Components

1. Plug and Chain Assembly
2. Screw
3. Waste Plate
4. Waste Body
5. Foam Washer
6. Rubber Washer
7. Backnut

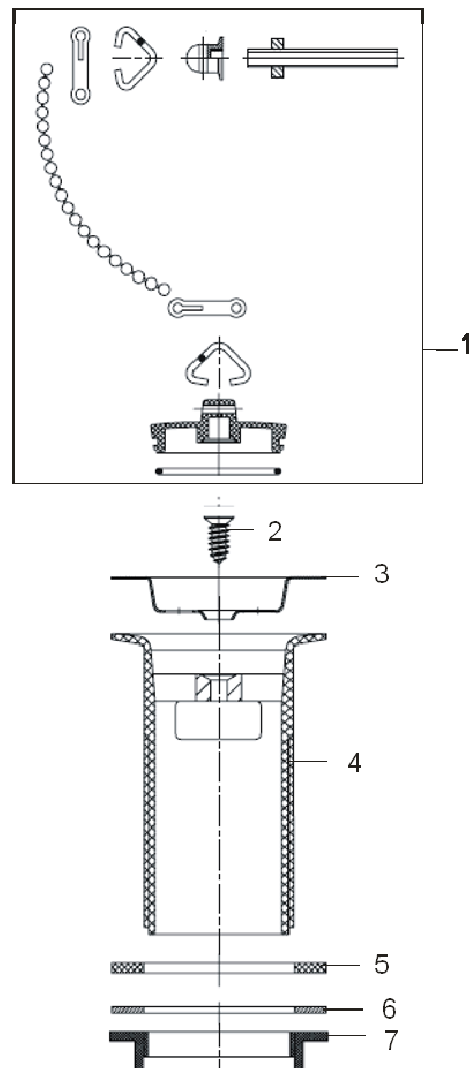

## Heritage Bathrooms Guarantee

When you buy a Heritage product, you can be confident that it not only features a beautiful, distinctive, classic design, but that it has also been made to the very highest quality standards.

In the unlikely event that you find a fault with our products, we offer solid guarantees and an attentive aftercare service to ensure that the problem is dealt with quickly and easily.

Please note that guarantees are only valid with proof of purchase.

Our guarantees are as follows:



2 Years for WC Seats (unless stated) and Stainless Steel Accessories



5 Years on Bathscreens, Furniture, shower Valves, Clifton Accessories and taps and wastes.



10 Years on Enclosures, Accessories (Except Clifton) And Cistern Fittings.



25 Years an Acrylic and Cast Iron Baths. Sanitaryware and Shower Trays

## Register now for additional peace of mind

Register your product with us now and, if you do have any queries after installation, we'll be able to quickly identify the product and give you the best advice. It also means that you won't have to keep your proof of purchase to validate your guarantee. To register, simply go online at

[www.heritagebathrooms.com](http://www.heritagebathrooms.com)

## Guarantee Terms and Conditions

This guarantee is in addition to your statutory and other legal rights and is subject to the following conditions:

- The product was purchased within the United Kingdom or Republic of Ireland
- The product is used in domestic applications only
- The guarantee applies solely to the original purchaser with proof of purchase
- The installation must allow ready access to all products for the purpose of inspection, maintenance or replacement
- Repair under this guarantee does not extend the original expiry date. The guarantee on any replacement parts or product ends at the original expiry date

Any part found to be defective during the guarantee period will be replaced without charge, providing that the product has been installed in accordance with the instructions given in this guide and used as the manufacturer intended. If the product is no longer available, Heritage will endeavour to provide the nearest equivalent.

The guarantee does not cover:

- Damage or defects caused by
  - General wear and tear (including special non-chrome finishes; components such as filters, seals, 'O' rings and washers)
  - Incorrect installation
  - Repair using non-Heritage parts
  - Accidental or wilful misuse
  - Corrosion and the use of inappropriate cleaning products.
  - System debris including the build-up of limescale (which can be controlled through regular servicing and maintenance)
- Compensation for loss of use of the product or consequential loss of any kind.

In the interests of continuous product improvement, Heritage reserves the right to alter product specifications without notice.

## Need help?

In the unlikely event that you encounter a problem with your Heritage product, you must, in the first instance, contact the retailer you purchased it from. They will advise as to whether it is due to a manufacturing fault or an installation fault. If the problem is due to a manufacturing fault, they will contact us to arrange a supply of a replacement product as soon as possible. To speak to a Heritage customer service advisor, please contact our technical helpline on **0844 701 8503**.

**Notes**

# HERITAGE<sup>®</sup>

## BATHROOMS

This booklet covers product codes:

THC10

THA10

**Helpline**

**0844 701 8503**

Heritage Bathrooms  
Birch Coppice Business Park  
Dordon  
Tamworth  
B78 1SG

Website: [www.heritagebathrooms.com](http://www.heritagebathrooms.com)

Telephone: 0844 701 8501

Email: [Technical@heritagebathrooms.com](mailto:Technical@heritagebathrooms.com)