

# ASQUITHS

BATHROOMS OF TRANSFORMATION

BRASSWARE FITTING GUIDE



# GENERAL FITTING GUIDE

## 3/4" SIDE VALVES (PAIR)

PRODUCT SHOWN WILL VARY  
DEPENDING ON MODEL

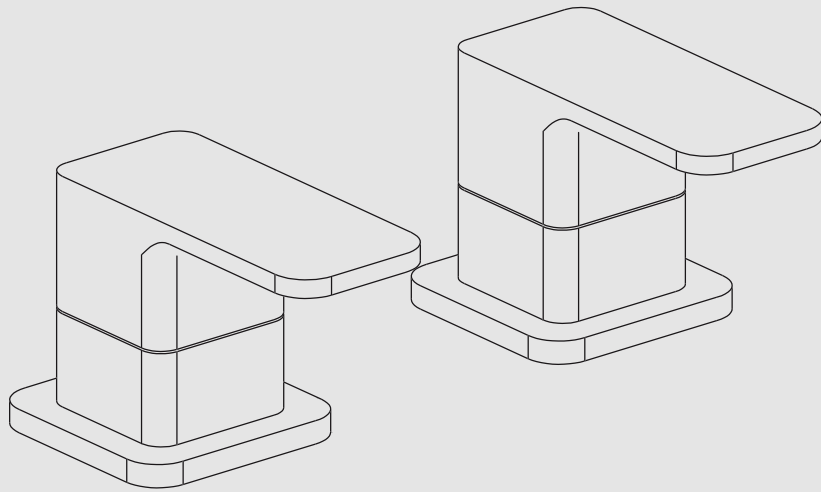

### Guarantee & Aftercare

When installing or using tools, extra care must be taken to avoid damaging the finish or fitting. To maintain the appearance, please ensure it is cleaned regularly using a clean soft damp cloth only. Abrasive cleaners or detergents must not be used as they may cause surface deterioration. The company provides a guarantee against faulty material or manufacture excluding serviceable parts, providing they have been installed, cared for and used in accordance with our instructions.

### Water Supply Regulations

This product has been manufactured to comply with the appropriate BS EN Standards and to conform to Water Supply Regulations 1999.

### Earth Bonding

Earth any new pipework satisfactorily (Seek expert advice if in doubt).

The company reserves the right to continually evolve its product lines without notification. The company will not accept any liability regarding specification changes and their consequences unless previously quoted by the company in writing.

### Installation Procedure

1. Prior to installation please ensure all the supply pipes have been flushed through to remove any debris and then ensure the water supply is turned off.
2. We strongly recommend the fitting of isolation valves to the inlet feeds for ease of future maintenance.
3. Ensure you have all the relevant tools before commencing the installation and take note of any specific markings on the product to make sure they are installed correctly.
4. Carefully assemble new fitting onto the bath. Do NOT over-tighten as this may cause damage to the fitting and/or bath. Remember to install the 'O' ring or washer between the mixer body & bath.  
Please ensure you take note of any specific markings on the product to make sure they are installed correctly
5. Connect water supply to the inlet connectors. The HOT supply should always be connected to the LH side when viewing the fitting from the front.  
Please ensure you take note of any specific markings on the product to make sure they are installed correctly
6. Ensure fitting is in the 'open' position and turn on the water supply. Allow the tap to run for a few minutes to flush out any debris.
7. Check all water feed connections to ensure there are no leaks.
8. Check the assembled fit of the products to the bath to ensure there is no water ingress that may cause water damage after installation.

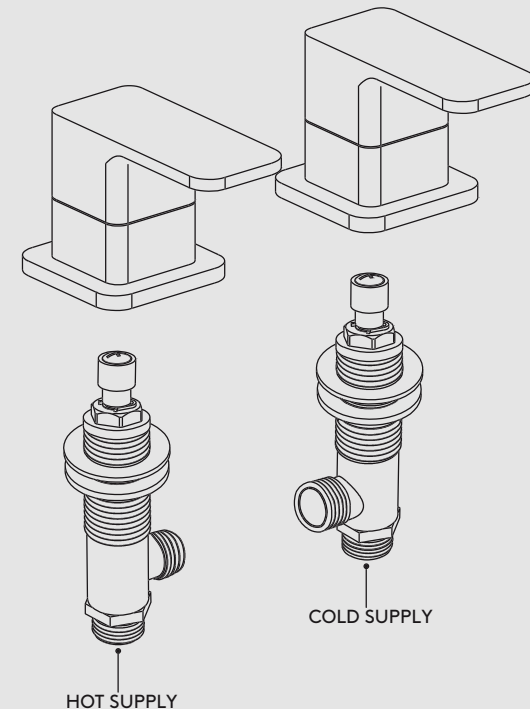



ASQUITHSBATHROOMS.COM