

# HERITAGE

## BATHROOMS

### Installation Instructions and User Guide

Single & Dual Control  
Exposed Top & Bottom  
Outlet Shower Valves

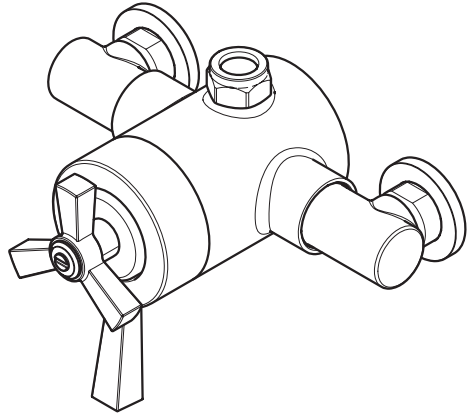

**Models covered:** SGRDCT03,  
SGRDCB03, SGRDDUAL04, SDAT06,  
SDCT06, SDAB06, SDCB06, SDCDUAL07,  
SDCDUAL08, SHDCT02, SHDCB02,  
SHDAT02, SHDAB02, SHDDUAL07,  
SHDDUAL08, SSOBCT03, SSOBCB03,  
SSOBDUAL03, SGCT03, SGCB03, SGAT03,  
SGAB03, SGSIN03, SGSIN04, AVEDUAL01,  
SGRDMOPDUAL01, SGRBLSIN01

Please keep this booklet for future reference.

Installer, when you have read these  
instructions please ensure you leave them  
with the user.

# Contents



Thank you for choosing Bristan, the UK's leading showers and taps expert.

Your Bristan mixer tap is a thermostatic mixer incorporating a wax capsule thermostat to ensure constant temperatures. These instructions are for your guidance to a safe and successful installation and should be left with the user.

All products manufactured and supplied by Bristan are safe providing they are installed correctly and receive regular maintenance in accordance with these instructions.

Important Safety Information.....	3
General Information.....	4
Specifications.....	5
Installation Requirements.....	6-9
System Requirements.....	6-7
WRAS IRN's .....	8
Conditions of Use .....	9
Prior to Installation.....	10
Installation.....	11-12
Operating the Shower .....	13
Commissioning .....	14
Maintenance .....	15-18
Cartridge Cleaning .....	15
Non-Return Valve Cleaning .....	16
Temperature Setting .....	17-18
Troubleshooting.....	19-20
Notes .....	21
Guarantee.....	22-23

# Important Safety Information

- Please read these instructions thoroughly and retain for future use.
- All products manufactured and supplied by Bristan are safe provided they are installed, used correctly and receive regular maintenance in accordance with these instructions.
- If you are in any doubt about your ability to install this mixer tap safely you must employ the services of an experienced qualified plumber.
- These fittings need to be installed in accordance with, and meet the requirements of the Water Supply (Water Fittings) Regulations 1999 and Scottish Byelaws 2004.
-  **Warning:** Do not operate the mixer if you suspect it is frozen. Do not site the mixer valve where it might be subjected to freezing conditions.
- Remove all packaging and check the contents for damage before starting installation.
- Before starting any installation please consider the following: before drilling into walls, check that there are no hidden electrical wires, cables or water supply pipes. This can be checked with the aid of an electronic detector.
- If power tools are used do not forget to:
  - Wear eye protection
  - Unplug equipment after use
- Fitting isolating valves to the inlet feeds is required for ease of maintenance.
-  **Warning:** Before installing the new mixer valve it is essential that you thoroughly flush through the pipework in order to remove any remaining swarf, solder, etc. Failure to carry out this procedure could cause problems or damage to the workings of the mixer tap.
- This mixer valve must not be modified in any way as this will invalidate the guarantee.

# General Information

Operating pressure range: Minimum 0.1 bar, Maximum 5.0 bar.

Maximum static pressure: 10.0 bar.

This product has been designed and tested to comply with the BS EN 1287:1999 (LP) and BS EN 1111:1999 (HP) thermostatic mixing valve standards.

BS 8558 recommends hot water should be stored and distributed at a temperature of not less than 60°C which will help minimise the build-up of lime scale in hard water areas.

If the fitting is installed at low pressure (tank fed), then the minimum distance from the outlet to the underside of the cold tank should be at least 1 metre to ensure adequate performance.

Note: Nominally equal (balanced) inlet supply pressures are recommended for optimum performance with mixer taps.

This shower valve should be installed in compliance with the Water Supply (Water Fittings) Regulations 1999 and the current Scottish Bylaws 2004.

If in doubt, contact a registered plumber or your Local Water Authority or the Secretary of The Institute of Plumbing, address as follows;-

The Institute of Plumbing,  
64 Station Lane,  
Hornchurch,  
Essex, RM12 6NB  
Tel:01708 472791

Recommended Usage			
Domestic	✓	Heavy Commercial	✗
Light Commercial	✗	Health Care	✗

# Specifications

## Specifications

Inlet connections: 15mm compression with 136-158 adjustable centres.

Outlet connection: 15mm compression.

Operating pressure range: Min. 0.2 Bar - Max. 5.0 Bar - Maximum recommended imbalance between hot and cold supply should not exceed a ratio of 5:1.

**Important: For Diverter only.** If using this product on a low pressure system (0.1-0.2bar) we recommend the NRV in the diverter to be removed to ensure maximum flow.

Maximum Static Pressure: 10 Bar

Maximum outlet temp: Factory pre-set to 42°C

(can be re-set to suit site conditions). If the temperature is re-set to suit different site conditions the mixer will work adequately however the TMV2 scheme will not apply.

Supply requirements:

Minimum cold water supply temperature: 5°C.

Maximum cold water supply temperature: 25°C.

Maximum hot water supply temperature: 80°C.

(a maximum hot water supply temperature of 60 - 65°C is recommended for ablutionary purposes)

Note: The inlet hot water temperature must be at least 10°C above the required blend temperature (eg. mixer temperature 41°C: minimum hot supply 51°C).

System Requirements

Gravity fed hot & cold (Equal pressures)

Gravity fed hot & mains cold (Different pressure, maximum ratio 5:1)

Unvented systems

Instantaneous water heater (combination boiler)

Pumped system

Note: when using a pumped system we recommend that an Essex flange is used.

Valves operating outside these conditions of use cannot be guaranteed to operate as type 2 valves.

# Installation Requirements

This shower valve must be installed in compliance with current water regulations. If you have any doubts about the water regulation requirements contact your local water services provider or use the services of a professional plumber.

This shower valve is suitable for use with the following water supply systems:

- **Gravity Fed Hot and Cold** (pressure balanced)
- **Gravity Fed Hot and Mains Cold** (differential pressure - see Specification section on page 5)
- **Instantaneous water heater** (combination boiler)
- **Unvented System**
- **Pumped System**

**⚠ Important:** If you install this shower valve with a gravity fed system, there must be a minimum head (vertical distance) from the underside of the cold water storage tank to the outlet of at least 1 metre .

**Note:** Pumped system (with Essex flange)  
If you install this shower valve to a pumped gravity fed system where the minimum head (vertical distance) from the underside of the cold water storage tank to the top of the hot water cylinder is less than 1 metre we recommend an Essex flange is used as shown.

## Flushing Pipe-work

**⚠ Important:** Before connecting the shower valve (see 'Installation' on pages 11-12), the supply pipe-work must be flushed to clear debris before connecting the mixer tap. Debris will reduce the performance and life of the mixer.

### Gravity Fed Hot and Cold

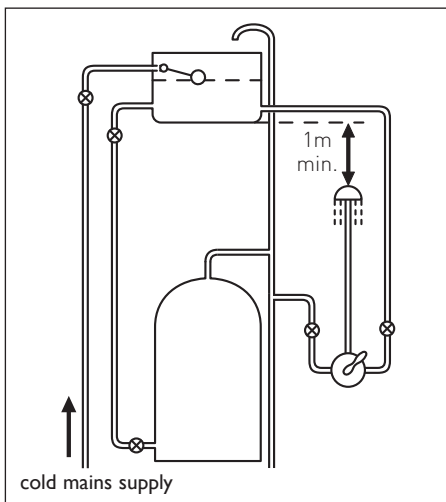

### Gravity Fed Hot and Mains Cold

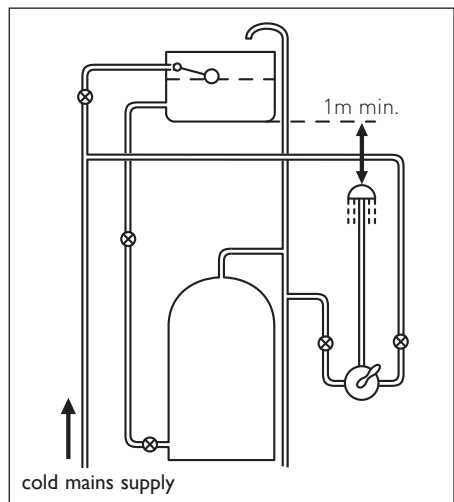

# Installation Requirements

## Instantaneous Water Heater

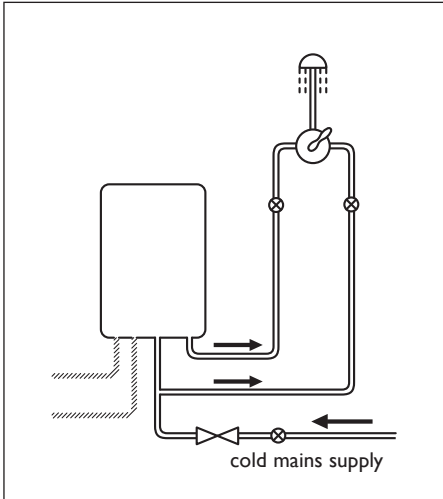

## Unvented System

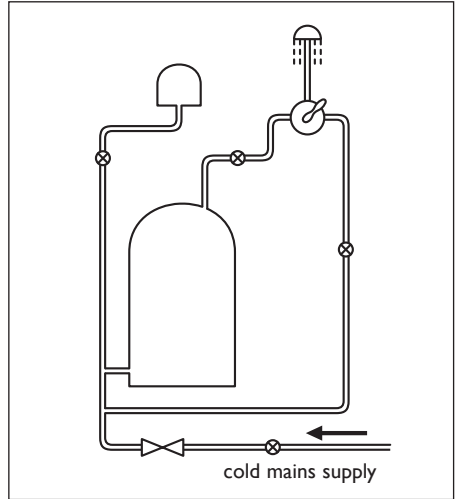

## Pumped System

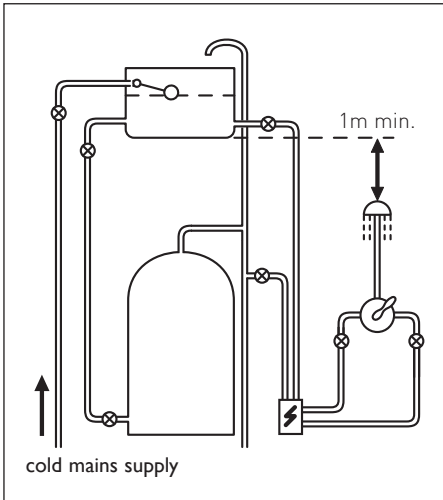

## Pumped System (with Essex flange)

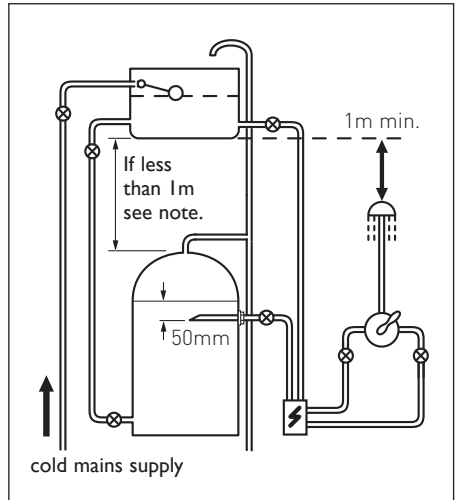

Key:



Isolating Valve



Reducing Valve



Shower Valve



Pump

Essex Flange

# Installation Requirements

This fitting needs to be installed in accordance with the following Installation Requirements and Notes (IRN) to ensure they meet the requirements of the Water Supply (Water Fittings) Regulations 1999 and the Scottish Byelaws 2004.

IRN R001: See text of entry for Installation Requirements or Notes.

IRN R040 - Schedule 2-15 (1): The fitting shall be installed so that its outlet discharges above the spill-over level of any fixed appliance as indicated below:-

For backflow protection in domestic or installations up to, and including, Fluid Category 3.

If the fitting cannot be installed as indicated in the table opposite it shall be installed as either a or b below:

a: with an approved double check valve assembly or some other no less effective backflow prevention device immediately upstream of the inlet.

b: so that it draws water by gravity only from a cistern, or cylinder having a permanently open vent pipe, and the distributing pipe supplies no other fittings (other than a draining tap) at a lower level.

For backflow protection in premises or installations up to, and including Fluid Category 5.

The vertical distance of the outlet above the spill-over level shall be not less than 20mm or twice the diameter of the inlet pipe to the fitting, whichever is the greater. If the fitting cannot be installed as indicated it shall be installed with a backflow prevention arrangement suitable for the Fluid Category.

Size of tap or combination fitting	Vertical distance of outlet above spill-over level
1. Not exceeding 1/2"	20mm
2. Exceeding 1/2" but not exceeding 3/4"	25mm
3. Exceeding 3/4"	70mm



# Installation Requirements

## Conditions of use for Type 2 (Thermostatic mixer) valves

	High Pressure	Low Pressure
Maximum Static Pressure (Bar)	10	10
Flow Pressure, Hot & Cold (Bar)	0.5 to 5	0.1 to 1
Hot Supply Temperature (°C)	55 to 65	55 to 65
Cold Supply Temperature (°C)	Equal to or Less than 25	Equal to or Less than 25

**Note:** Valves operating outside these conditions cannot be guaranteed by the Scheme to operate as Type 2 valves.

If a water supply is fed by gravity then the supply pressure should be verified to ensure the conditions of use are appropriate for the valve.

## Recommended outlet temperatures

The BuildCert TMV scheme recommends the following set maximum mixed water outlet temperatures for use in all premises:

41°C for showers.

The mixed water temperatures must never exceed 46°C.

The maximum mixed water temperature can be 2°C above the recommended maximum set outlet temperatures.

**Note:** 46°C is the maximum mixed water temperature from the bath tap. The maximum temperature takes account of the allowable temperature tolerances inherent in thermostatic mixing valves and temperature losses in metal baths.

 **Warning:** It is not a safe bathing temperature for adults or children.

The British Burns Association recommends 37 to 37.5°C as a comfortable bathing temperature for children. In premises covered by the Care Standards Act 2000, the maximum mixed water outlet temperature is 43°C.

The thermostatic mixing valve (TMV) will be installed in such a position that maintenance of the TMV and its valves and the commissioning and testing of the TMV can be undertaken.

The fitting of isolation valves is required as close as is practical to the water supply inlets of the thermostatic mixing valve.

# Prior to Installation

## Flow Regulator removal.

This shower valve comes fitted with 2 x 8 litre per minute flow regulators fitted into each inlet elbow.

If the shower valve is to be installed on a low pressure system the flow regulators can be removed.

## To Remove the Flow Regulators

Unscrew the inlet elbows from the valve body.

Remove the flow regulators from the inlets.

Screw the elbows back onto the valve body.

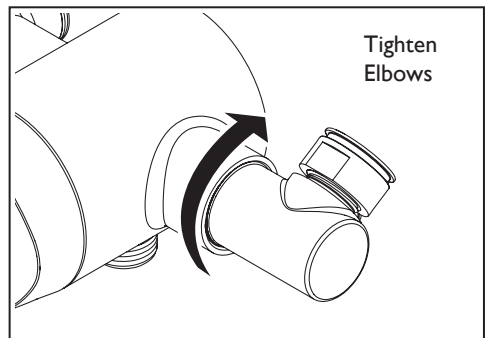
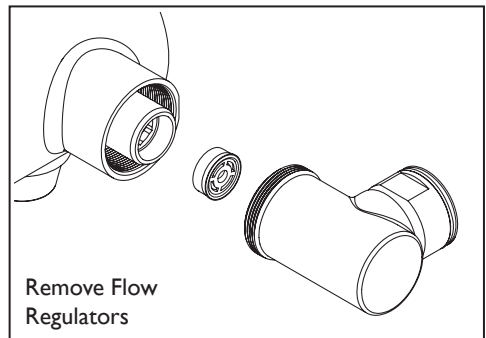
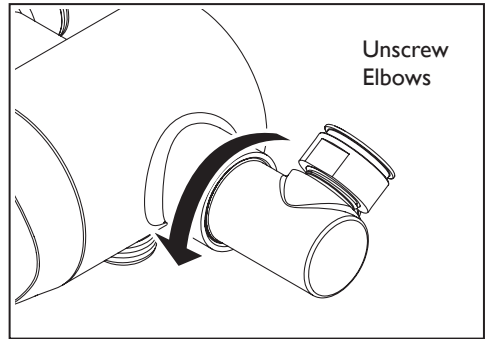

# Installation - Shower Valve

## Before Installation

Flush through the pipework to ensure removal of any debris. Turn off the mains water supply and close any isolating valves.

### 1. Inlet positions & supply pipework

This shower valve has three inlet positions - top, bottom and rear. Rotate the inlet elbows as required.

**!** **Important:** Always remember to fully tighten the inlet elbows if the position is changed.

Sufficient 15mm diameter supply pipework should protrude through the finished wall surface to fit fully into the shower valve elbows.

### 2. Attach backplate to wall

Loosen the backplate grub screw on the underside of the shower valve using a suitable hexagonal key.

Use the backplate as a template and mark the centres of the fixing holes onto the wall.

**!** **Warning:** Please check for any hidden pipes and cables before drilling holes into the wall.

Drill suitable holes and insert the wall plugs. Attach the backplate to the wall using the fixings supplied.

**Important:** Water supplies to the mixer must be with hot on the left and cold on the right when viewed from the front.

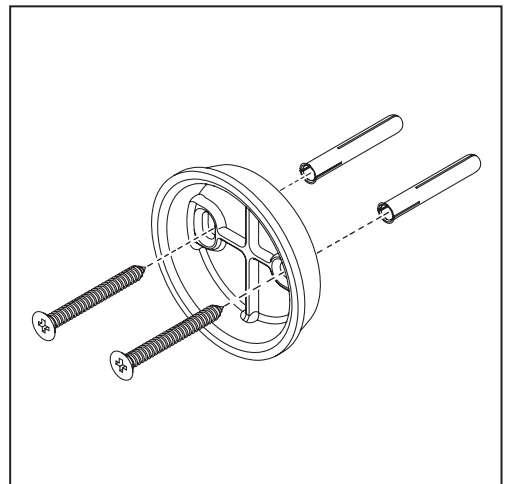
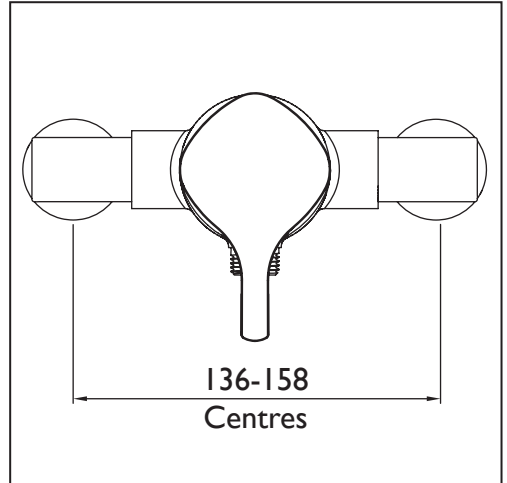

# Installation - Shower Valve

## 3. Attach shower valve

Place the shrouds, nuts and olives over the water supply pipes. Fit the shower valve onto the backplate, inserting the 15mm hot and cold water supply pipes into the inlet connections and tighten the nuts. Ensure the olives are fitted to the water supply pipes.

Secure the shower valve to the wall by tightening the grub screw on the underside of the body, using a suitable hexagonal key.

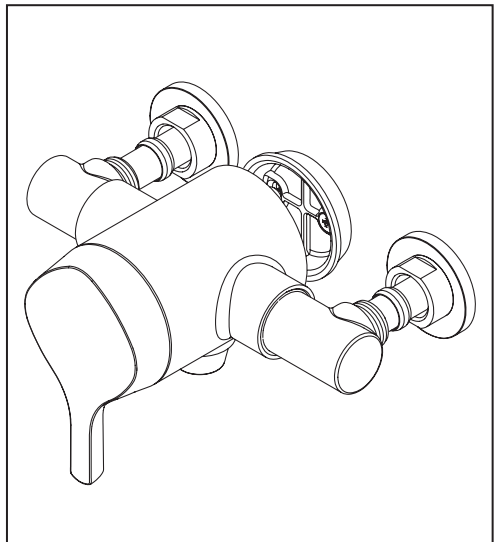
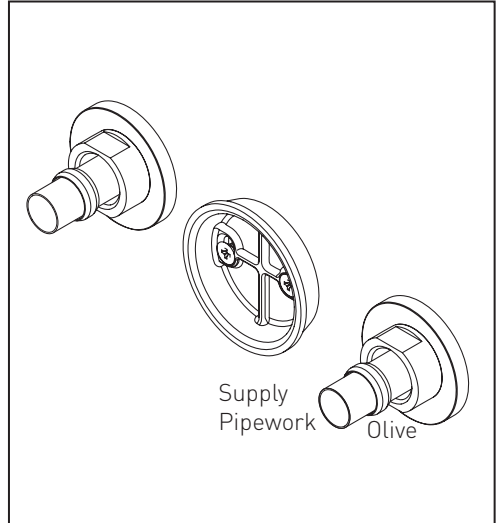

# Operating the Shower

## Sequential Shower Valve

Turn the control handle clockwise to turn the flow of water on.

Continue to turn the flow lever to increase the water temperature.

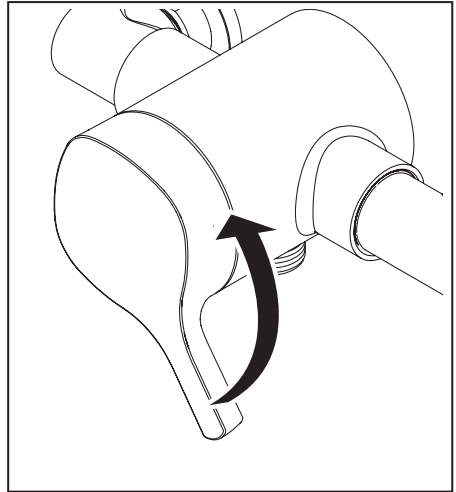

## Concentric Shower Valve

Turn the flow lever clockwise to turn on the flow of water.

The further the handle is turned the greater the flow of water.

Turn the temperature lever clockwise to increase the water temperature.

The further the handle is turned the hotter the water temperature.

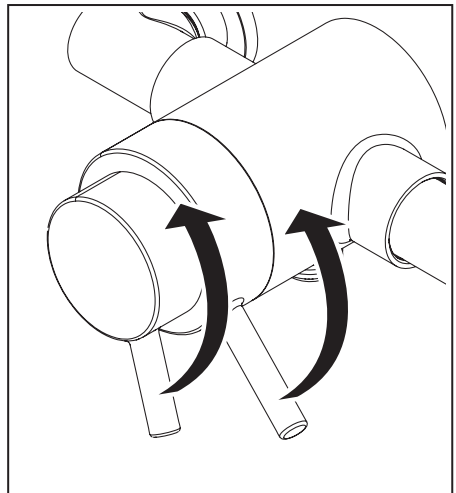

# Commissioning

## Commissioning notes for Thermostatic Mixing Valves

The first step in commissioning a thermostatic mixing valve is to check the following:

1. The designation of the thermostatic mixing valve matches the application.
2. The supply pressures are within the valves operating range.
3. The supply temperatures are within the valves operating range.
4. Isolating valves (and strainers preferred) are provided.

If all these conditions are met, proceed to set the temperature as stipulated in the Maintenance section.

The mixed water temperature at the terminal fitting must never exceed 46°C.

When commissioning / testing is due the following performance checks shall be carried out:

- Measure the mixed water temperature at the outlet.
- Carry out the cold water supply isolation test by isolating the cold water supply to the TMV, wait for five seconds, if water is still flowing check that the temperature is below 46°C.

If there is no significant change to the set outlet temperature (+/-2°C or less change from the original settings) and the fail-safe shut off is functioning, then the valve is working correctly and no further service work is required.

**Notes:** If there is a residual flow during the commissioning or the annual verification (cold water supply isolation test), then this is acceptable providing the temperature of the water seeping from the valve is no more than 2°C above the designated maximum mixed water outlet temperature setting of the valve.

Temperature readings should be taken at the normal flow rate after allowing for the system to stabilise.

The sensing part of the thermometer probe must be fully submerged in the water that is to be tested.

Any TMV that has been adjusted or serviced must be re-commissioned and re-tested in accordance with the instructions in the Maintenance section.

The installation of thermostatic mixing valves must comply with the requirements of the Water Supply (Water Fittings) Regulations 1999.

## General Cleaning

Your fitting has a high quality finish and should be treated with care to preserve the visible surfaces. All surfaces will wear if not cleaned correctly, the only safe way to clean your mixer is to wipe with a soft damp cloth. Stains can be removed using washing up liquid. All bath cleaning powders and liquids will damage the surface of your fitting, even the non-scratch cleaners.

**Note:** Never use abrasive detergents or disinfectants or those containing alcohol, hydrochloric acid or phosphoric acid.

# Maintenance - Cartridge Cleaning

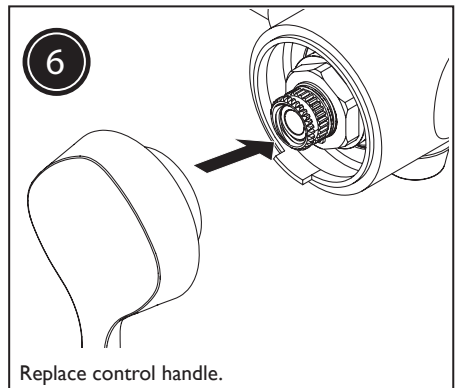
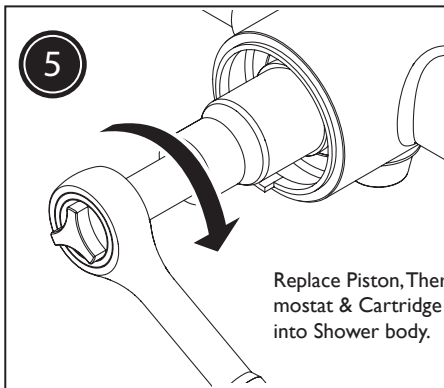
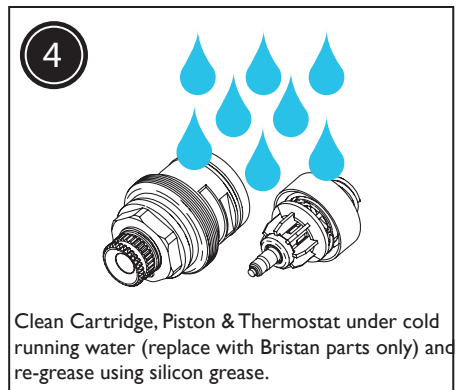
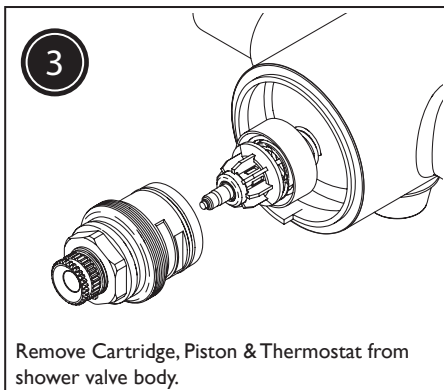
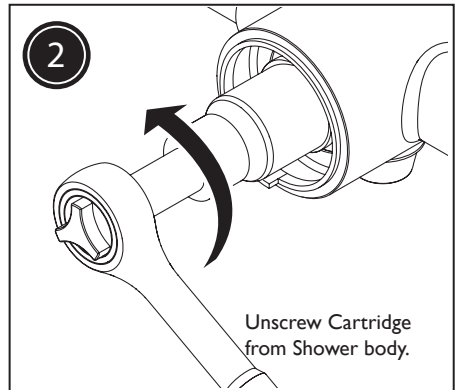
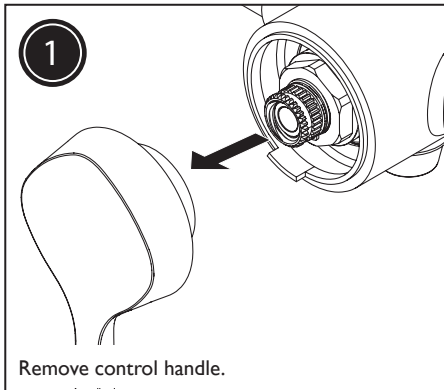

# Maintenance - NRV Cleaning

## Non Return Valve Maintenance

If the shower valve does not function correctly the non return valves may need cleaning / replacing. To service the non return valves the following should be carried out.

### 1. Isolate Water Supplies

Isolate both hot and cold water supplies to the shower valve by either;

Turning the water supply off at the mains stopcock or,

Turning off the isolation valves to the shower valve.

### 2. Remove Elbows

Unscrew the elbows from the shower valve. Remove the flow regulators (if fitted).

### 3. Remove Non Return Valves

Using a 10mm hexagonal key unscrew the non return valve housing from the shower valve inlet. Push the NRV out from the housing.

Clean the non return valve under cold running water. If damaged replace using a replacement supplied by Bristan.

Replace the non return valve into the housing and replace into the shower valve body, tightening with a 10mm hexagonal key.

### 4. Replace Elbows

Push the flow regulators into the shower valve inlets (If used). Screw the elbows back onto the shower valve inlets.

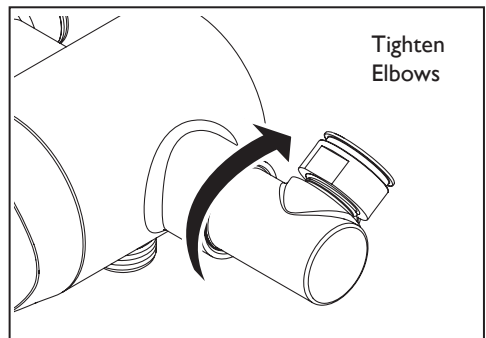
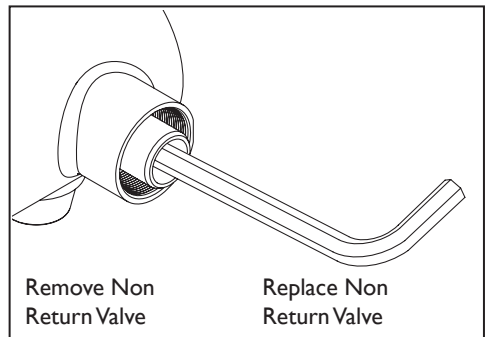
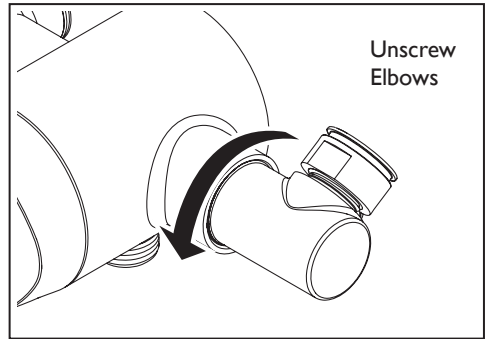



# Maintenance - Temperature Setting

## Adjusting the Temperature

The shower valve has been factory set with equal (balanced) hot and cold water supply pressures with the hot water supply at 65°C.

If your operating conditions are different from those above, the outlet water temperature may differ from the factory setting.

If required the shower valve can be re-calibrated to suit your own temperature requirements.

Turn the temperature control anti-clockwise (hotter) fully until it stops and check the temperature of the water with a thermometer. If the temperature is not correct, re-calibrate the shower valve following the steps below.

## Sequential Valves

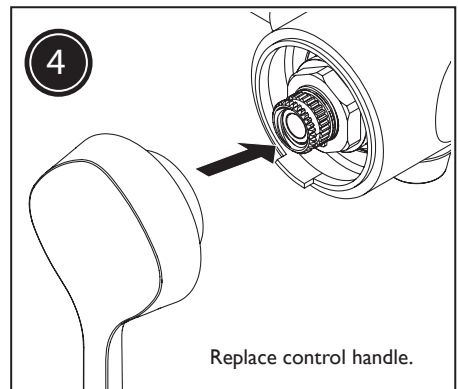
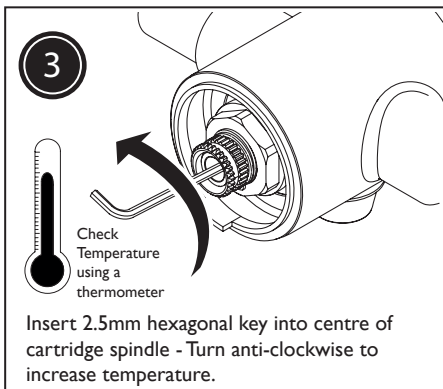
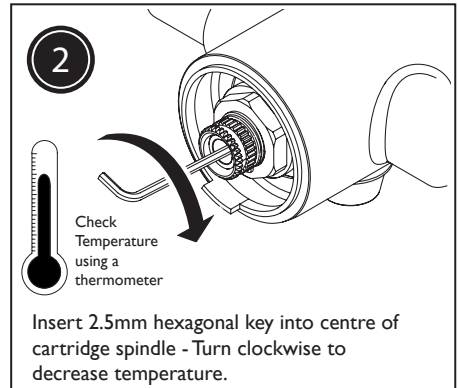
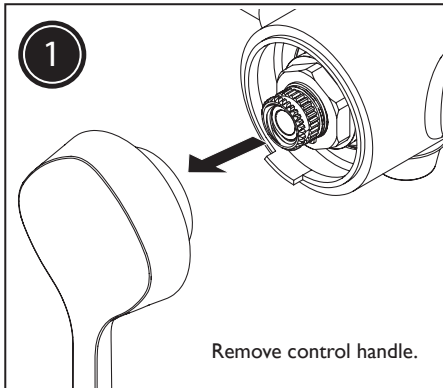

# Maintenance - Temperature Setting

## Concentric Valves

If required the shower valve can be re-calibrated to suit your own temperature requirements.

Turn the flow control to the 'on' position.

Turn the temperature control anti-clockwise (hotter) fully until it stops and check the temperature of the water with a thermometer. If the temperature is not correct, re-calibrate the shower valve following the steps below.

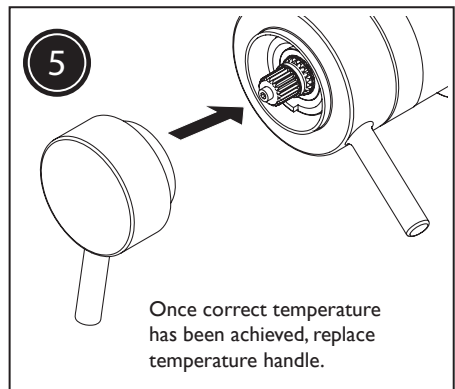
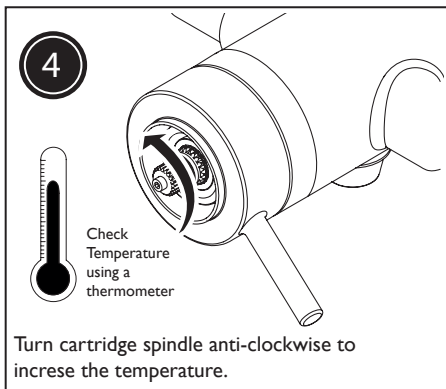
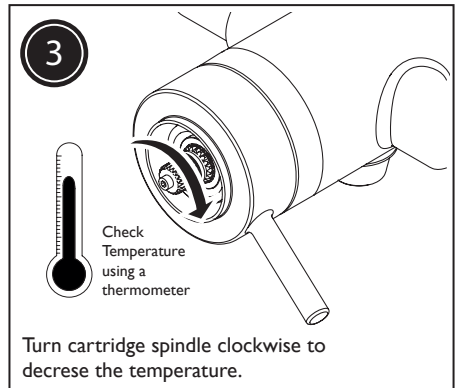
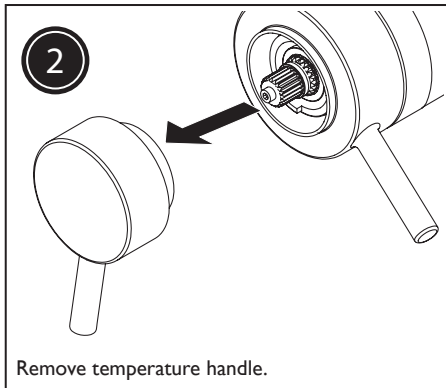
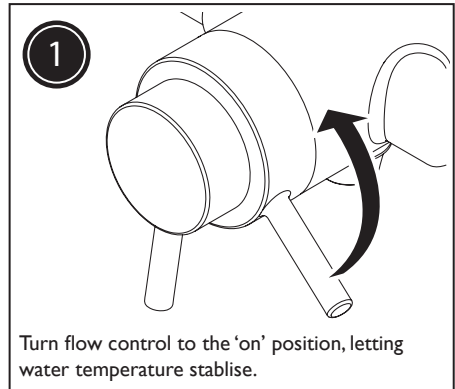

# Troubleshooting

Symptom	Cause	Remedy
No flow or low flow rate and / or varying temperatures.	Check showerhead, hose and filters for any blockage.	Clean as necessary, refer to Maintenance section (pages 15-18).
	Partially closed stop or service valve in water supply pipework to the shower valve.	Open stop or service valve.
	Instantaneous water heater cycles on and off as the flow rate or pressure is too low.	Increase water flow rate or pressure through system. Contact the boiler manufacturer.
	Head of water is below the minimum distance required.	Raise the cistern or fit a shower booster pump.
	Inlet filter is partially blocked.	Clean or replace, flush through pipework before refitting.
	Hot or cold water being drawn off elsewhere causing pressure changes or instantaneous boiler temperature changes.	Do not use other water outlets when using the shower.
	Make sure the maintained inlet pressures are nominally balanced and sufficient.	Refer to Specification (page 5).
	Airlock or partial blockage of the pipework.	Flush through pipework to ensure removal of debris and any airlocks.
Only hot or cold water from the shower valve outlet.	No hot or cold water reaching the shower valve.	Check hot and cold feeds (the valve will shut down if either the hot or cold supply fails).
	Partially closed stop or service valve in water supply pipework to the shower valve.	Open stop or service valve.
	Inlet filter is partially blocked.	Clean or replace, flush through pipework before refitting.
	Inlet water supplies are reversed (hot to cold supply).	Check the connections are the correct way round. Hot on the left and cold on the right when viewed from the front. Rework pipework as necessary.

# Troubleshooting - cont.

Symptom	Cause	Remedy
Maximum water temperature too hot or cold.	Maximum water temperature set incorrectly.	Reset maximum water temperature. Refer to 'Temperature setting' in Maintenance section (pages 17-18).
Outlet water temperature too hot / cold.	Inlet filter is partially blocked.	Check inlet filters for any blockages and clean as necessary.
	Installation conditions outside operating parameters.	Refer to Specification (page 5). Service shower valve as recommended. Refer to Maintenance section (pages 15-18). Refer to 'Temperature Setting' section (pages 17-18).
Water temperature too cold - Maximum water temperature incorrectly set.	Hot water temperature is less than 10°C above the required blend temperature.	Adjust hot water temperature or wait for water to reheat if stored system is used.
	Instantaneous water heater not igniting because water flow rate is too low.	Increase water flow rate through the system.  Check inlet filters and clean or replace. Refer to Maintenance section (pages 15-18).  Contact the boiler manufacturer.

# Notes

Please use this space to add any notes you or your installer may have regarding the plumbing system / installation of this product.

# Guarantee

When you buy a Heritage product, you can be confident that it not only features distinctive design, but that it has also been made to meet our rigorous quality standards.

We offer robust guarantees and an attentive aftercare service to ensure that if you do experience any issues, we can deal with a problem quickly, and effectively,

Please note that guarantees are only valid with proof of purchase,  
Our guarantees are as follows:



2 Years on  
Mirrors & WC  
Seats



5 Years on  
Bath Screens,  
Furniture,  
Shower Valves,  
Taps, Wastes,  
Washstands &  
Accessories



Lifetime Guarantee  
on Acrylic & Cast  
Iron Baths and  
Sanitaryware

## Register now for additional peace of mind

Register your product with us now and, if you do have any queries after installation, we'll be able to quickly identify the product and give you the best advice. It also means that you won't have to keep your proof of purchase to validate your guarantee. To register, simply go on-line at [www.heritagebathrooms.com/register](http://www.heritagebathrooms.com/register)

## Guarantee Terms and Conditions

The guarantee is in addition to your statutory and other legal rights and is subject to the following conditions:

- The product was purchased within the United Kingdom or Republic of Ireland
- The product is used in domestic applications only
- The guarantee applies solely to the original purchaser with proof of purchase
- The installation must allow ready access to all products for the purpose of inspection, maintenance or replacement
- Repair under this guarantee does not extend the original expiry date. The guarantee on any replacement parts or product ends at the original expiry date

Any parts found to be defective during the guarantee period will be replaced without charge, providing that the product has been installed in accordance with the instructions given in this guide and used as the manufacturer intended. If the product is no longer available, Heritage will endeavour to provide the nearest equivalent.

# Guarantee & Service Policy

The guarantee does not cover:

- Damage or defects caused by
  - General wear and tear (including special non-chrome finishes; components such as filters, seals, o-rings and washers)
  - Incorrect installation
  - Repair using non-Heritage parts
  - Accidental or wilful misuse
  - Corrosion and the use of inappropriate cleaning products
  - System debris including the build-up of limescale (which can be controlled through regular servicing and maintenance)
- Compensation for loss of use of the product or consequential loss of any kind

In the interests of continuous product improvement, Heritage reserves the right to alter product specifications without notice.

## Need help?

In the unlikely event that you encounter a problem with your Heritage product, you must, in the first instance contact the retailer you purchased it from. They will advise as to whether it is due to a manufacturing fault or an installation fault. If the problem is due to a manufacturing fault, they will contact us to arrange a supply of a replacement product as soon as possible. To speak to a Heritage customer service advisor, please contact our technical helpline on **0844 701 8503**.



# HERITAGE<sup>®</sup>

BATHROOMS

Heritage Bathrooms  
Birch Coppice Business Park  
Dordon  
Tamworth  
B78 1SG

Website: [www.heritagebathrooms.com](http://www.heritagebathrooms.com)  
Telephone: 0844 701 8503  
Email: [technical@heritagebathrooms.com](mailto:technical@heritagebathrooms.com)

