

SK005 Alternative wall fixing bracket assembly

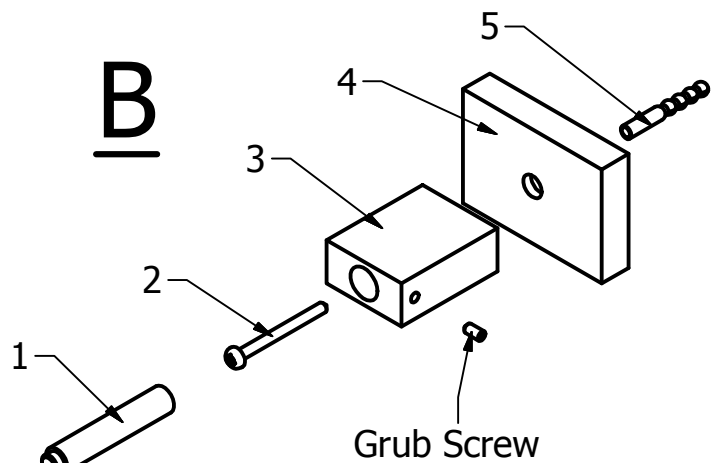
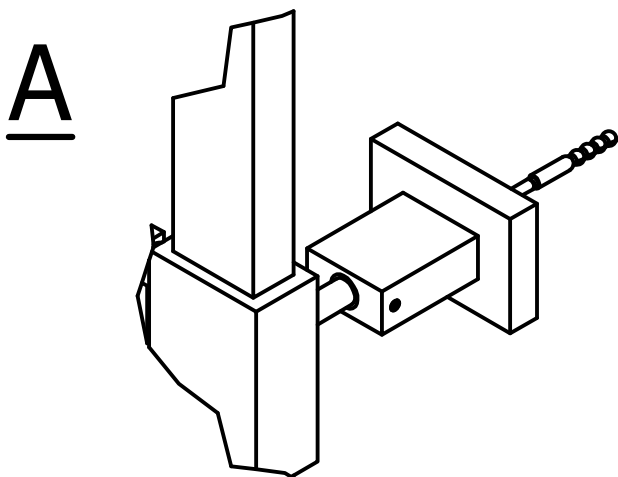
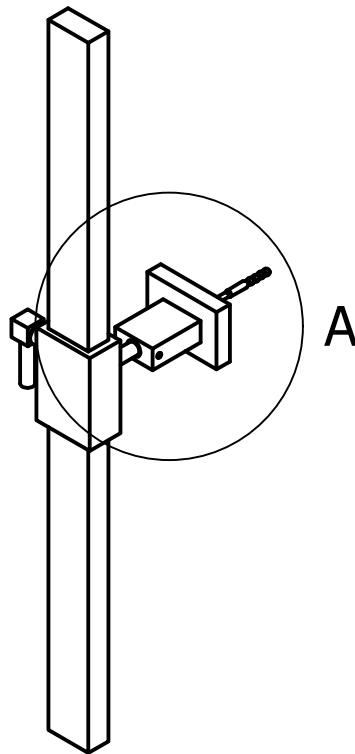

1. Mark the wall position for the fixing plate (No4). Drill wall and place plug provided (No5).
2. Screw to wall by placing screw (No2) through the spacing plate (No3) and fixing plate (No4), using sequence shown in diagram B
3. screw fixing pin (No1) to ridged riser.
4. adjust accordingly.
5. fix into position using grub screw provided.