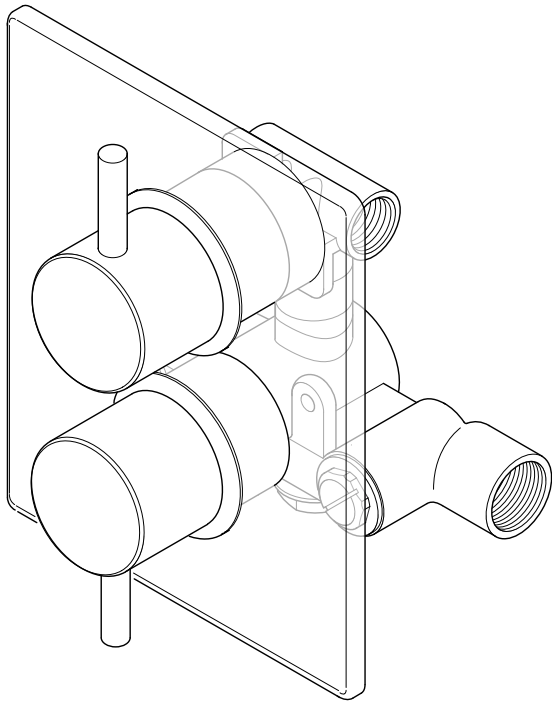


**TRITON**



86002290

**ELINA**  
**Dual control Thermostatic**  
**built-in mixer shower with diverter**



**Installation and**  
**operating instructions**



**The showerhead and hose supplied with this product are a safety critical part of your shower. Failure to use genuine Triton parts may cause injury and invalidate your guarantee.**



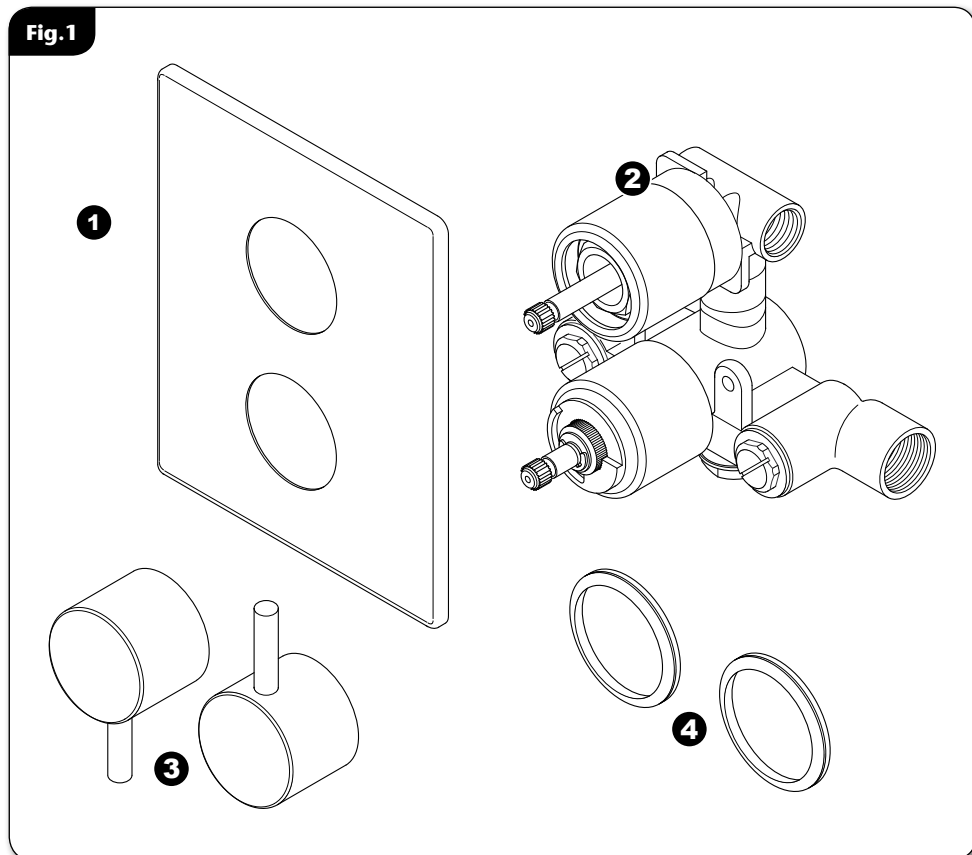
<b>CONTENTS</b>	<b>Page</b>
MAIN COMPONENTS .....	1
INTRODUCTION.....	2
SITE REQUIREMENTS .....	2
SAFETY WARNINGS .....	2
PLUMBING REQUIREMENTS .....	3
WATER SYSTEM REQUIREMENTS .....	3
TYPICAL COMMERCIAL INSTALLATIONS .....	4
TYPICAL DOMESTIC INSTALLATIONS .....	5 - 7
INSTALLATION.....	8 - 10
BUILT-IN FITTING .....	9
Installation in a solid wall.....	9
Installation in a hollow wall .....	10
Installation in a panel wall or cubicle.....	10
FITTING THE MIXER .....	11
FITTING THE BULKHEAD PIPEWORK.....	11
MAKING GOOD .....	12
BULKHEAD ASSEMBLY .....	12
To fit flow regulators.....	13
ANTI-SCALD PROTECTION .....	13
Recommended outlet temperatures - <b>TMV2</b> .....	13
COMMISSIONING.....	14
ADJUSTING THE MAXIMUM TEMPERATURE STOP.....	14 - 15
Control knob assembly.....	14 - 15
OPERATING THE SHOWER (Diverter).....	16
APPROVALS .....	17
<b>TMV2 REQUIREMENTS (12 MONTHLY VERIFICATION)</b> .....	17
FLOW CHART .....	17
DIMENSIONS .....	18
SPARE PARTS.....	19
MAINTENANCE .....	20
FAULT FINDING.....	21 – 22
TEST RECORD.....	23
Guarantee, service policy, etc. ....	rear cover

INSTALLERS PLEASE NOTE THESE INSTRUCTIONS ARE TO BE LEFT WITH THE USER

To check the product suitability for commercial and multiple installations, please contact Triton's specification advisory service before installation. Please see back off book for contact information.

## MAIN COMPONENTS

Fig.1



### Ref. Description

1. Cover plate
2. Mixer shower body
3. Knobs X2
4. Cover plate seal X2

**Note:** water inlet and outlet fittings are **NOT** supplied with this product.

Water inlets require **x2 3/4" BSP fittings.**

Water outlet requires **x2 1/2" BSP fitting.**

All dimensions listed in this fitting book regarding the product and installation are approximate.

\*All kits are for illustration purposes only and are not supplied unless otherwise stated.

## INTRODUCTION

This book contains all the necessary fitting and operating instructions for your mixer shower. Please read them carefully and read through the whole of this book before beginning your installation.

The shower installation must be carried out by a suitably competent person and in sequence of this instruction book.

Care taken during the installation will give a long and trouble free life from your mixer shower.

## SITE REQUIREMENTS

The installation must be in accordance with water supply (water fittings) regulation 1999 and/or local Bylaws.

### Water pressure requirements

*Running water pressure:*

Low pressure*	- 0.1 bar min. 1.0 bar max.
High pressure	- 0.5 bar min. 5.0 bar max.

*Maximum static water pressure:*

Low & High pressure	- 10 bar
---------------------	----------

\*This mixer shower is designed for high pressure systems found in the UK, but can be installed with low pressure gravity water systems with reduced flow rates.

For effective operation of the internal seals, the maximum static pressure must not be exceeded.

### Pressure reducing valve

On sites where the running pressure is above 5 bar, the use of a suitably sized pressure reducing valve fitted in the cold mains supply pipe work can provide nominally equal pressures at the mixer shower.

### Water minimum flow rate

For best performance within the specified running pressure range a minimum flow of 8 litres per minute should be available to both inlets.

### Water temperature requirements

Recommended maximum:	= 65°C
Minimum hot water temperature:	= 55°C
Maximum cold water temperature:	= 25°C

**NOTE:** Valves operating outside these conditions cannot be guaranteed by the Scheme to operate as Type 2 valves.

A stored water temperature of 60°C is considered sufficient to meet all normal requirements and will minimise the effects of scale in hard water areas.

### Water temperature adjustment and thermal safety

The mixed water temperature can be adjusted from cold through to a top limit which must be preset during installation with full anti-scald protection throughout the range (35°C to 40°C) providing the hot water temperature at the inlet remains 10°C above the outlet temperature.

Should there be a loss of flow to either incoming supply then- water from the shower will stop or be reduced until both supplies are restored.

## SAFETY WARNINGS

- DO NOT** choose a position where the shower could become frozen.
- DO NOT** connect this mixer shower to any form of tap or fitting not recommended by the manufacturer.
- DO NOT** allow the inlet pressure or flow rates to operate outside the guidelines laid out in 'site requirements'.
- DO NOT** connect the mixer shower to a gravity hot supply and a mains cold supply (or vice versa).

Replacement parts can be ordered from Triton Customer Service. See 'spare parts' for details and part numbers.

## PLUMBING REQUIREMENTS

**DO NOT** use jointing compounds on any pipe fittings for the installation.

**DO NOT** solder fittings near the mixer unit as heat can transfer along the pipework and damage the mixer valve.

**DO NOT** subject the unit to a water temperature above 80°C during installation, use, maintenance or disinfection.

### IMPORTANT:

- The layout and sizing of pipework **MUST** be such that nominally equal inlet supply pressures are achieved and the effects of other draw-offs are minimised.
- The pipe-work should be installed such that other taps and appliances being operated elsewhere on the premises do not significantly affect the flow.
- When connecting pipe-work avoid using tight 90° elbows; swept or formed bends will give the best performance.
- The hot water pipe entry **MUST** be made to the left-hand side inlet, marked HOT, 'H' or with a red/orange label.
- Suitable isolating valves (complying with Water Regulations and Bylaws) **MUST** be fitted on the hot and cold water supplies to the shower as an independent means of isolating the water supplies should maintenance or servicing be necessary.
- It is preferable to flush the pipe-work to clear the system of debris and check for leaks before connecting to the mixer.
- The mixer inlets contain removable filters that may become blocked if debris is not flushed through before fitting.

### (Commercial applications)

- Triton recommends for all commercial applications that, easily accessible, in-line filters are used to aid maintenance.

## Hard water areas

- a. If it is intended to operate the shower in areas of hard water (above 200-ppm temporary hardness), a scale inhibitor may have to be fitted. For advice on the scale inhibitor, please contact Customer Service.
- b. For best performance the showerhead **MUST** be regularly cleaned to remove scale and debris.

## WATER SYSTEM REQUIREMENTS

This mixer shower is suitable for:

- Gravity water systems.
- Pumped gravity systems.
- Fully modulating type combination boilers.
- Multi-point hot water heaters.
- Thermal storage.
- Unvented systems.

When installing this mixer with a Combination or multi-point boiler, it may be necessary to install flow regulation.

Check that the appliance is capable of delivering hot water at a minimum switch-on flow rate of 3 litres per minute. At flow rates between 3 and 8 litres per minute, the appliance **MUST** be capable of raising the water temperature to 52°C (minimum).

Water temperature at the inlet of the mixer valve **MUST** remain relatively constant when flow rate adjustments are made (refer to the appliance-operating manual to confirm compatibility with this mixer shower).

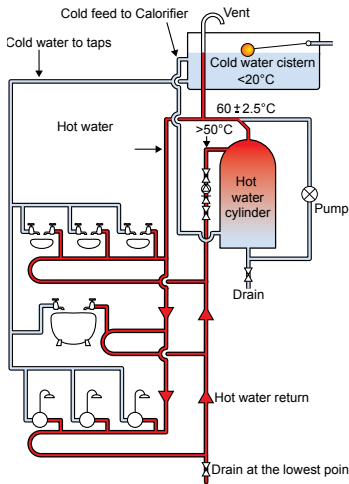
Where thermal store systems and instantaneous gas water heaters are used, if excessive draw-off take place the appliance may not be able to maintain an adequate output temperature. This could result in the shower temperature becoming noticeably cooler.

Flow regulators can be fitted with high-pressure water systems to reduce flow rate and assist economy.

The hot supply temperature **MUST** remain a minimum of 10°C hotter than the required blend temperature for optimum performance.

**\*Fig.2**

*\*(diagrammatic view – not to scale)*



## TYPICAL COMMERCIAL INSTALLATIONS

### Commercial gravity fed systems (fig.2)

The shower control **MUST** be fed from a cold water cistern and hot water cylinder providing nominally equal pressures. There **MUST** be a minimum of one metre head of water.

The minimum head distance is measured from the base of the cold water cistern to top of the showerhead.

### Commercial unvented mains pressure systems (fig.3)

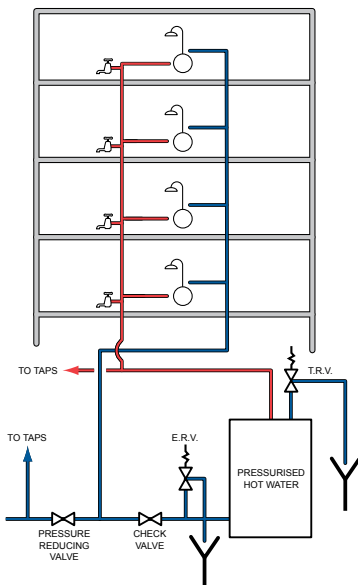
The shower control can be installed with an unvented, stored hot water cylinder.

For systems with no cold water take off after the appliance-reducing valve, it will be necessary to fit an additional drop tight pressure-reducing valve when the mains pressure is over 5 bar. The drop tight pressure reducing valve must be set at the same value as the unvented package pressure reducing valve.

**NOTE:** An additional expansion vessel may be required if a second pressure-reducing valve is installed. This does not apply to packages with a cold take off after the pressure-reducing valve to the cylinder.

**\*Fig.3**

*\*(diagrammatic view – not to scale)*



*\*(kits are for illustration purposes only)*

## TYPICAL DOMESTIC INSTALLATIONS

### Domestic gravity fed systems (fig.4)

The shower control **MUST** be fed from a cold water cistern and hot water cylinder providing nominally equal pressures. There must be a minimum of one metre head of water. The minimum head distance is measured from the base of the cold water cistern to top of the showerhead.

If valves are gravity fed then supply pressure should be verified to ensure conditions of use are appropriate for the valve.

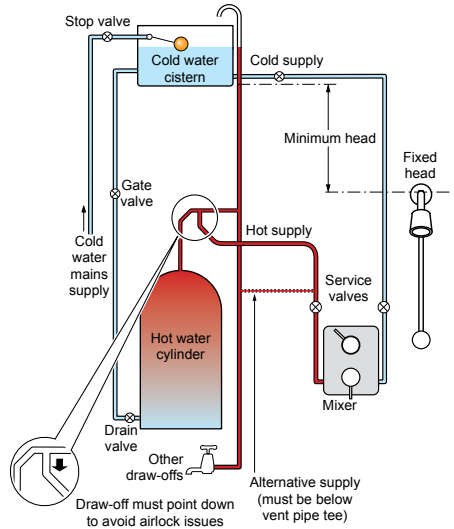
### Pumped gravity fed systems (fig.5)

The shower control **MUST** be fed from a cold water cistern and hot water cylinder providing nominally equal pressures.

The mixer unit may be used with a gravity fed system with a pump to boost pressures as shown; please refer to the pump installation guide to establish the minimum head requirements for automatic operation of the pump

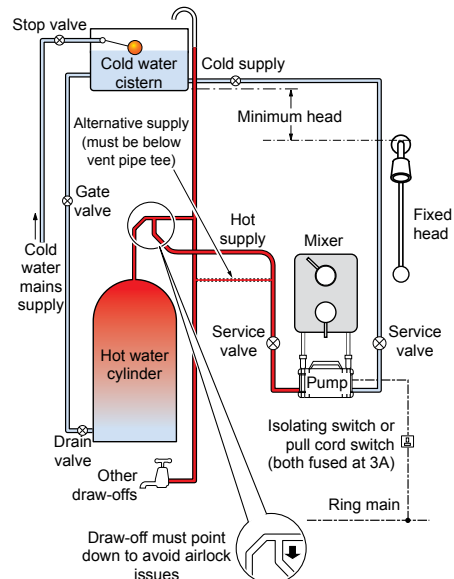
\*Fig.4

\*(diagrammatic view – not to scale)



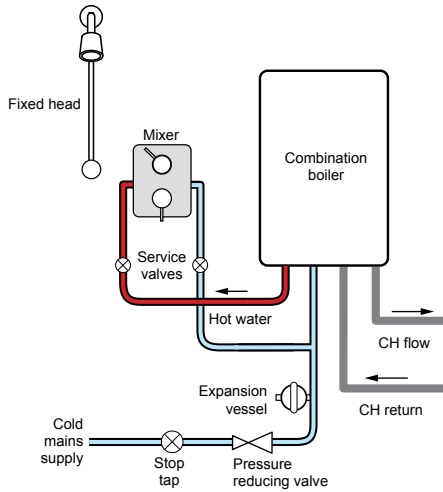
\*Fig.4

\*(diagrammatic view – not to scale)



**\*Fig.6**

\*(diagrammatic view – not to scale)



**Instantaneous gas-heated systems, e.g. combination boilers (fig.6)**

The shower control **MUST** be installed with a multi-point gas water heater or combination boiler of a fully modulating design (i.e. to maintain relatively stable hot water temperatures).

A drop tight pressure reducing valve **MUST** be fitted if the supply pressures exceed 5 bar running.

An expansion vessel may be fitted, and regularly maintained, to prevent the shower mixer being damaged by excess pressures. This may already be installed within the boiler (check with manufacturer) and is in addition to the normally larger central heating expansion vessel.

**Unvented mains pressure systems (fig.7)**

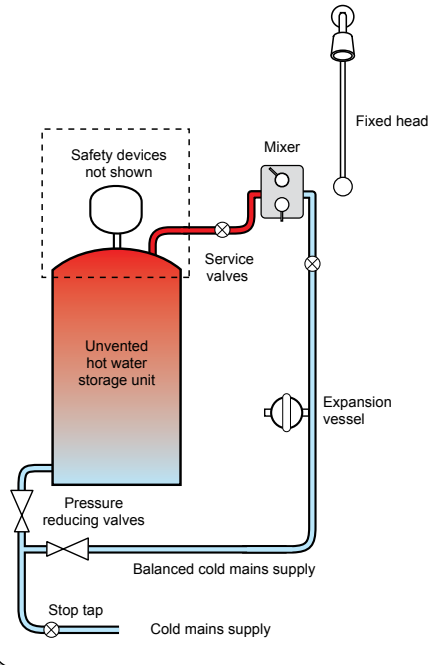
The shower control can be installed with an unvented, stored hot water cylinder.

For systems with no cold water take off after the appliance reducing valve, it will be necessary to fit an additional drop tight pressure-reducing valve when the mains pressure is over 5 bar. The drop tight pressure reducing valve must be set at the same value as the unvented package pressure reducing valve.

**Note:** An additional expansion vessel may be required if a second pressure-reducing valve is installed. This does not apply to packages with a cold take off after the pressure-reducing valve to the cylinder.

**\*Fig.7**

\*(diagrammatic view – not to scale)

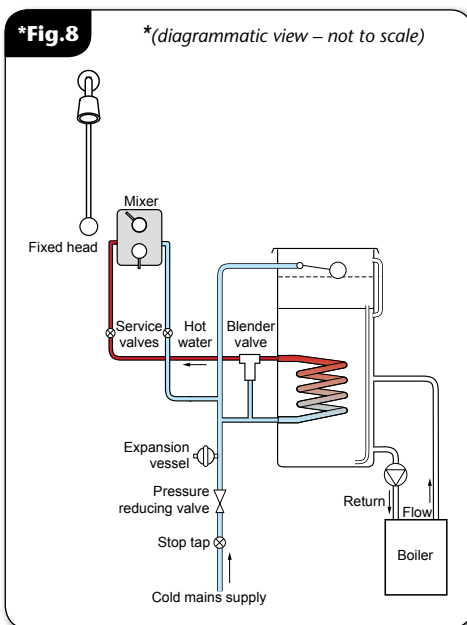




**Mains pressurised thermal store systems (fig.8)**

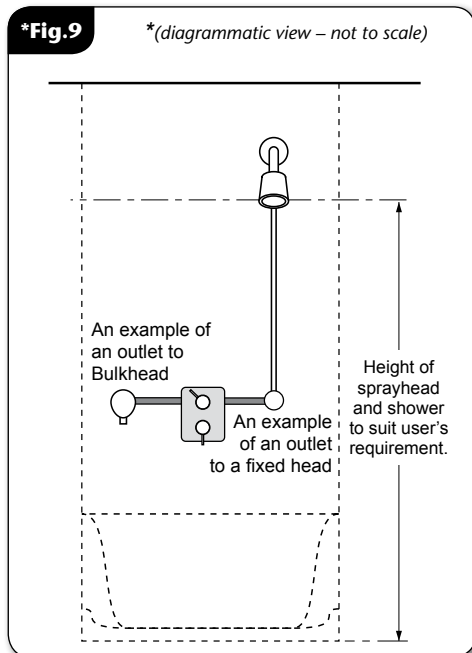
Packages of this type, fitted with a tempering valve (blender valve) can be used. A drop tight pressure reducing valve **MUST** be fitted if the supply pressures exceed 5 bar running.

An expansion vessel **MUST** be fitted, and regularly maintained, to ensure, the unit, is not damaged by excess pressures. This may already be installed externally or internally within the thermal store (check with thermal store manufacturer).



**\*Fig.9**

*\*(diagrammatic view – not to scale)*



## INSTALLATION

### Preparing the mixer valve

Check the contents to make sure all parts are present.

Before starting the mixer installation, make sure all the openings on the valve are carefully covered to stop ingress of any debris, etc. while routing the supply pipework.

The shower valve is suitable for built-in installation in:

- a solid wall,
- a stud partition wall
- dry lined wall
- or fixing to a shower cubicle or panel.

### Siting of the shower and accessories

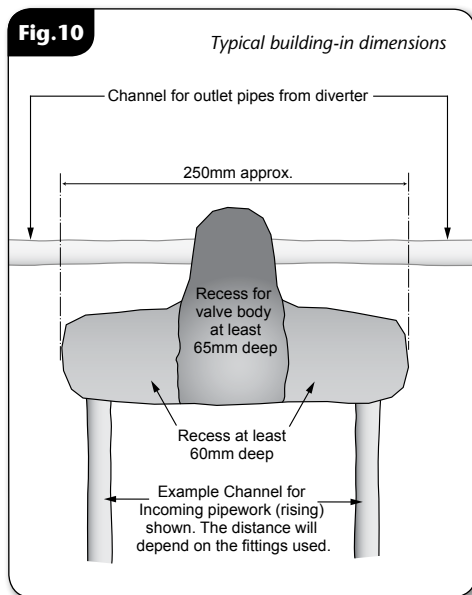
Refer to **(fig.9)** for correct siting of the shower.

The mixer valve should be positioned, as detailed, with all controls within comfortable reach of the user.

The accessories (showerhead, riser rail and/or fixed showerhead) can be positioned above or to either side of the shower, refer to **(fig.9)**.

**Fig.10**

*Typical building-in dimensions*



### Supply pipe work

Complete the pipework to the shower area having decided on the position of the shower and direction of pipe entry (for example rising, falling or rear entry)

The hot and cold water pipes should not be permanently attached to the wall within one metre of the valve, before installation is complete, to allow for final adjustment of the valve position.

### Rear entry supplies

Using a spirit level, mark the route of incoming hot and cold water supply pipes.

**NOTE:** *The distance between centres will be determined by the fittings used (fig.10).*

*\*(kits are for illustration purposes only)*

## BUILT-IN FITTING

The following are typical thicknesses and are given as a guide only:

Tile	6 – 10mm
Adhesive	2 – 3mm
Plasterboard	9.5 – 12.5mm
Plaster finish	2 – 3mm

Maximum tile thickness to be 10mm.

When installing into a stud partition or other hollow wall structure, the installer may wish to consider building rear supports or other options for fitting the mounting plate. Such options are beyond the scope of this guide.

Use the cover plate or tiling shroud (if supplied) as a template when cutting the opening for installing the shower into a solid wall, stud partition or hollow wall structure.

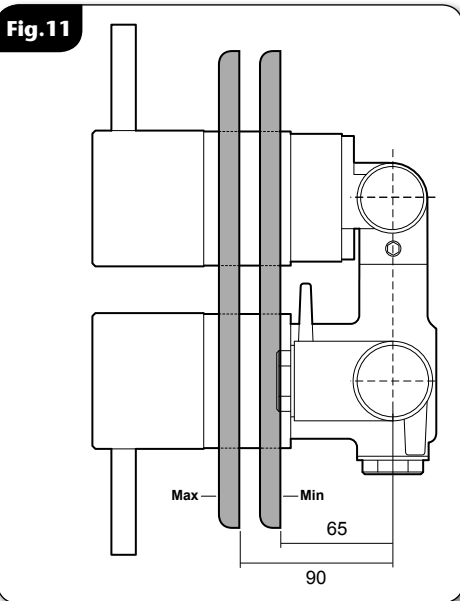
The building-in depth for the mounting plate is given in **(fig. 11)** from the plaster finish but this is dependent upon tile and adhesive thicknesses.

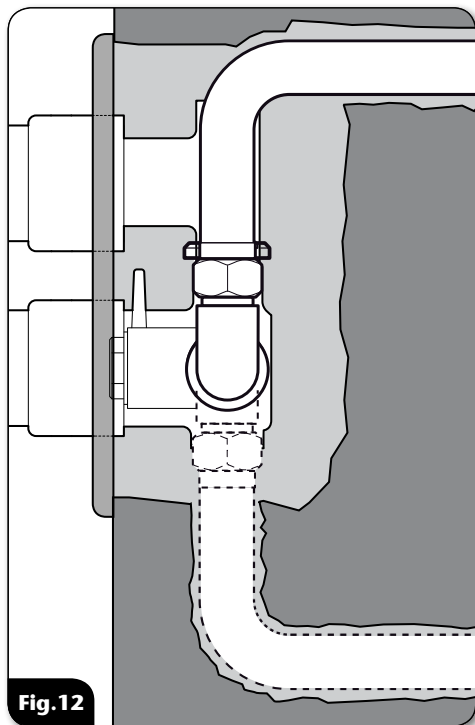
The inlet elbows allow for either rising, falling or rear entry hot and cold water supplies.

**NOTE:** *To ease future requirements for cleaning and maintenance of the unit, it is advisable to route both the incoming and outgoing pipework from the same direction. Access to the integral strainers will also be improved with this layout.*

### Installation in a solid wall

- Decide on the shower position and determine whether the hot and cold water supplies will enter the shower from top (falling) or bottom (rising) or rear.
- As a guide for the size of hole, it should be large enough to accept the valve complete with the inlet and outlet fittings and also allow access for connection to the pipework.
- Remove the plaster and brickwork to the required depth and chase out any additional areas of the wall to give access to the pipework to and from the valve plus any outlet fittings. Note that the valve body requires a deeper recess than the inlet and outlet fittings.





**NOTE:** The outlet pipework must end in a suitable female thread parallel 15mm x 1/2" BSP fitting (not supplied).

- Offer the valve body up to the wall and mark the fixing holes. Remove the valve, drill and plug the wall. Route the pipework to valve body position.

### **Installation in a hollow wall**

- Decide on the shower position and determine whether the hot and cold water supplies will enter the shower from the top (falling) or bottom (rising) or rear (**fig. 12**).
- When installing into a stud partition or other hollow wall structures, the installer will need to consider fabricating rear supports or other options. Such options are beyond the scope of this guide.
- Mark the route of the incoming and outgoing pipework.
- Take out the plasterboard (use the cover plate as a template). Offer the valve body up to the fabrication and mark the fixing holes.
- Remove the valve and drill the holes. Route the pipework to the valve position.

### **Installation in a panel wall or cubicle**

When installing into a panel or cubicle structure the installer will need to consider fabricating rear supports or other options. Such options are beyond the scope of this guide.

Typically, there should be at least 65mm space from the surface of the panel to the rear of the valve body.

**IMPORTANT:** Access to the rear of the valve must be available.

- The controls require two holes to be cut out of the panel or cubicle. Use the face plate as a template to mark the hole positions then extend further to allow access for the filters.
- Route the pipework to valve position.

## FITTING THE MIXER

- Mark the position of two locating screws.
- Drill and plug the holes. (Use an appropriate masonry drill, but if the wall is plasterboard or a soft building block, use special wall plugs and a suitable drill bit).

**IMPORTANT:** Make sure that all supply pipework has been flushed through before fitting the mixer (**fig.13**).

- Connect the hot water supply to the inlet marked HOT, 'H' or red/orange label and connect the cold water supply to the inlet marked COLD, 'C' or blue label.
- Tighten all compression fittings
- Secure the mixer to the wall.

## FITTING THE BULKHEAD PIPEWORK

- Complete the outlet pipework ending in a 15mm x 1/2" BSP female thread elbow (**fig.14**).

**Note:** This fitting is not supplied as variations in installations require the selection of a suitable solder or compression fitting.

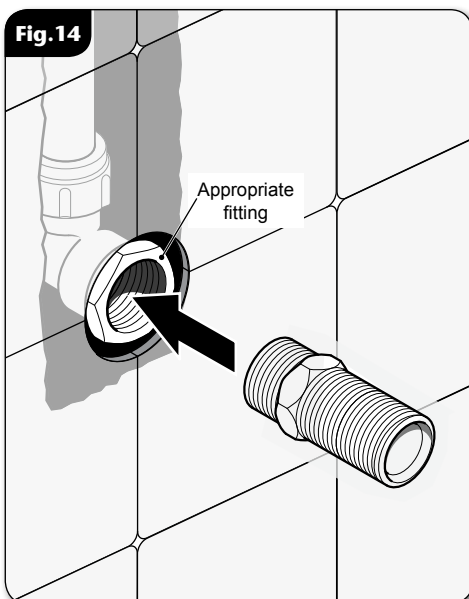
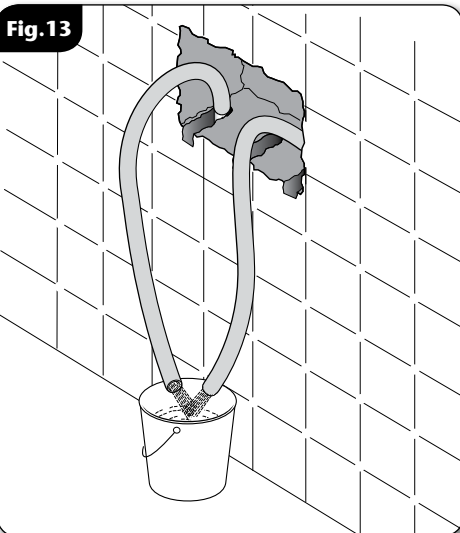
- Screw the supplied male-thread connector into the female fitting (**fig.15**) using PTFE tape to give a watertight joint.

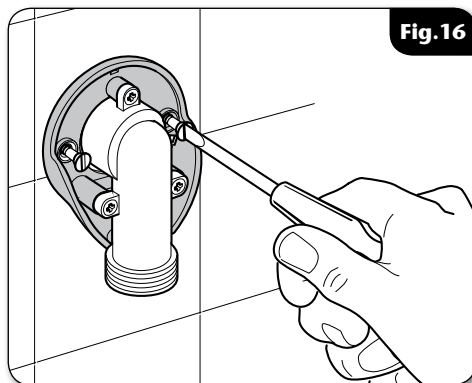
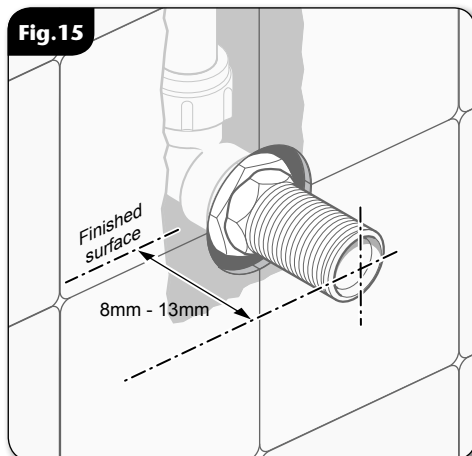
**NOTE:** The male-thread connector supplied has a shoulder. If fitting into a flush wall, make an additional 8mm allowance for this shoulder at the finished surface. The connector can be cut to size if required.

- The threaded connector should protrude from the finished wall surface between 8mm and 13mm.

## LEAK TESTING

Direct the outlet of the mixer to waste. Open the isolating valves to the shower and check for leaks. Remedy any leaks found.





## MAKING GOOD

### **Make good the wall and complete the tiling.**

- If the tiles are accurately cut, then the coverplate will seal around the hole in the tiles, and the valve unit will be able to be removed from the wall without the need to break any tiles.

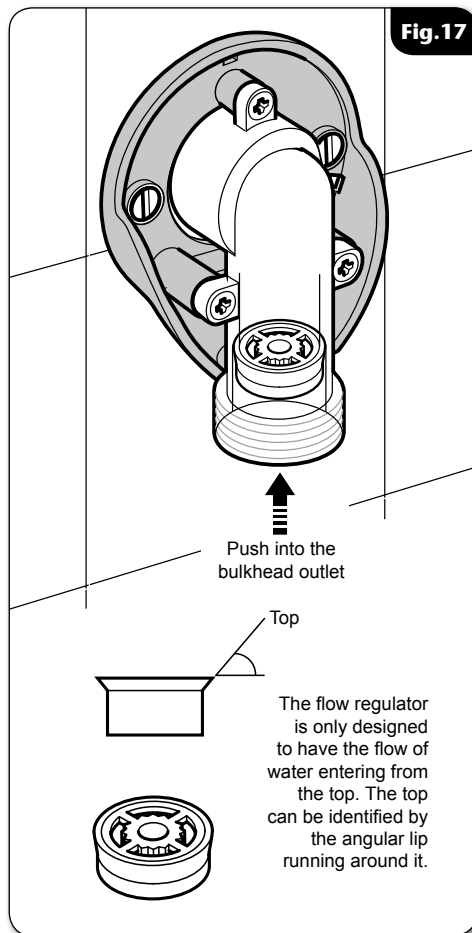
Make sure the grout lines around the valve are flush with the tiles in order to provide a smooth sealing surface for the coverplate.

## BULKHEAD ASSEMBLY

- Screw the bulkhead elbow to the bulkhead body with the three screws supplied.
- Screw the completed assembly onto the threaded connector temporarily to mark the position of the two fixing holes for securing the bulkhead to the wall.

**NOTE:** *If screw thread protrudes too far out of the wall, it can be cut to the correct length using a hacksaw.*

- Unscrew and remove the bulkhead assembly. Check the location of the pipe in the wall before drilling.
- Drill and plug the wall.  
*(An appropriate drill bit should be used. If the wall is brick, plasterboard or a soft building block, appropriate wall plugs and screws should be fitted).*
- If fitting to a hollow wall structure, it may be preferable to secure the bulkhead by applying a bead of silicon seal to the back of the bulkhead.
- Apply PTFE tape to the threaded connector.
- Screw the bulkhead assembly onto the threaded connector until tight to the wall and the two fixing holes are aligned. Secure to the wall with the two screws supplied **(fig.16)**.
- Finish by clipping the cover onto the bulkhead, making sure the protruding legs locate in the bulkhead body.



### Flow regulation

A flow regulator is supplied for use with high-pressure water systems and may be fitted with any of the systems listed to reduce flow rate and assist economy.

### To fit the flow regulator

To fit the flow regulators (flexible hose connection) press it into the outlet of the bulkhead, correctly. Please note the flow regulator is only designed to work in one direction (**fig. 17**).

### ANTI-SCALD PROTECTION

It is important that the mixer valve is tested regularly to prevent the risk of scalding and guarantee user safety. This can be carried out as follows: with the mixer blend temperature set at 38°C isolate the cold water supply. The outlet flow rate will reduce to a safe level.

### Recommended outlet temperatures

The **BuildCert TMV** scheme recommends the following set maximum mixed water outlet temperatures for use in all premises:

44°C - for bath fill but see notes below.

41°C - for showers.

41°C - for washbasins.

38°C - for bidets.

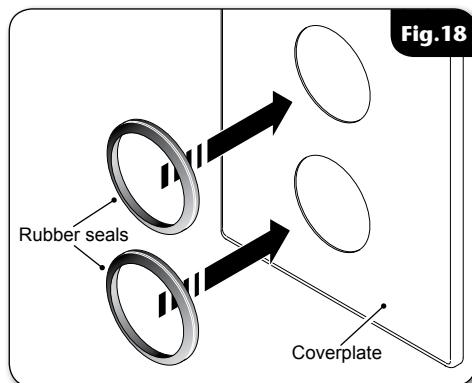
The mixed water temperatures must never exceed **46°C** at terminal fitting.

The British Burns Association recommends **37 to 37.5°C** as a comfortable bathing temperature for children. In premises covered by the Care Standards Act 2000, the maximum mixed water outlet temperature is **43°C**.

### Fitting the coverplate

Fit the coverplate over the valve body and slide tight to the wall.

Make sure the seals in the openings stays in place as it slides over the valve body. A smear of liquid soap on the seal will ease this procedure (**fig. 18**).



## COMMISSIONING

- Start the water flow by rotating the flow control
- Make sure that both the hot and cold water supplies are fully open and at (or near to) their design temperature and pressures, and are within the requirements as stated on **page 2**.
- Make sure the temperature control is at the maximum temperature setting.
- Allow the shower to run at the maximum temperature setting until the water temperature has stabilised. Rotate the temperature control until your desired maximum showering temperature is reached.

The mixer has a temperature stop to prevent accidental rotation to higher temperatures. This is adjustable to provide a maximum temperature of 35°C – 40°C and should be checked on site to guarantee user safety.

### Temperature adjustment range

The mixed water temperature can be adjusted from cold through to a top limit (which can be pre-set during installation – factory set at approximately 38°C) with full anti-scald protection throughout the range.

## ADJUSTING THE MAXIMUM TEMPERATURE SETTING (and fitting the knobs)

### Control knob assembly

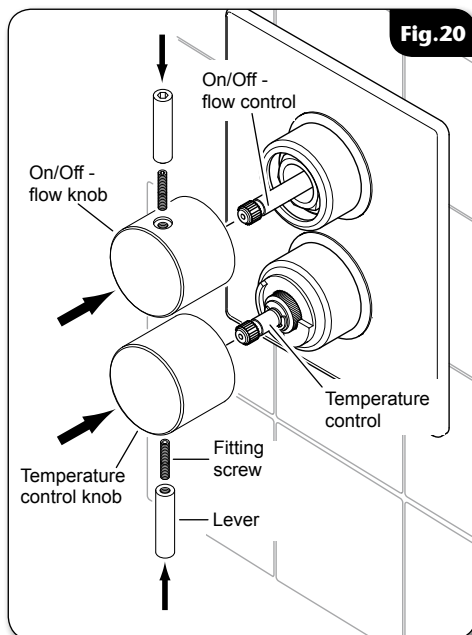
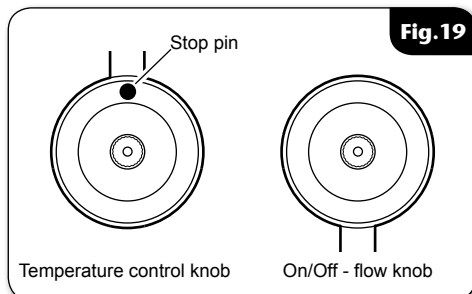
There are two knobs supplied, one is the

**On/Off - flow knob**

and the other is the

**Temperature control knob**.

- The knobs must be fitted in the correct order, failure to do so will cause incorrect operation of the shower. The temperature control knob has a metal “stop pin” on the inside (**fig.19**).
- Fit the On/Off - flow knob onto the correct spindle (**fig.20**), secure to the spindle using the screw supplied and fit the trim.

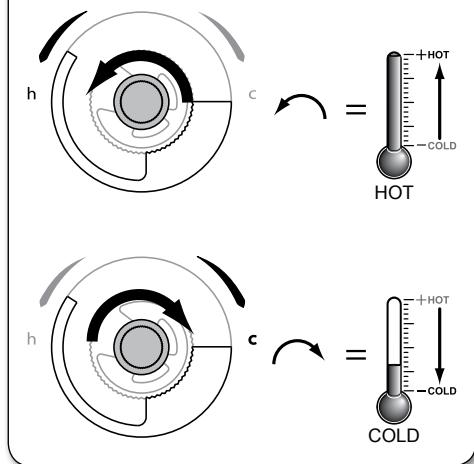


**Note:** If ‘Tamper proof’ lever fitting is required, tighten the levers into the controls using a suitable Allen key placed into the recessed ‘hex’ end of the lever.

**DO NOT OVERTIGHTEN THE LEVERS.**

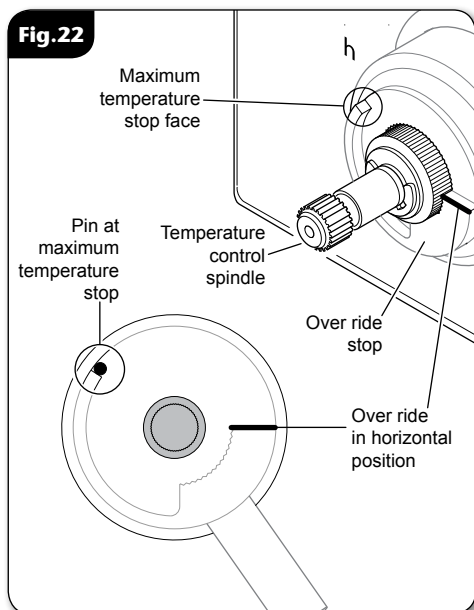


Fig.21



- See the correct position to fit the temperature stop in **(fig.21)**.
- The temperature control knob is fitted in the same way, but **Do not** secure with the fitting screw until the commissioning procedure is complete.
- With a steady flow running, allow the unit time to stabilise at its maximum set temperature, if required adjust the temperature control spindle by hand **(fig.21)**.
- When the showering temperature is satisfactory turn off the shower.
- Fit the temperature control knob, making sure the maximum temperature stop pin is as close to the flat edge of the over ride stop as possible **(fig.22)**.

Fig.22



## OPERATING THE SHOWER

### (Diverter) (fig.23)

When the ON/OFF Diverter control knob is at 12 o'clock, it is in the OFF position.

To use the Left outlet turn the Diverter control to the left. As the lever is moved towards the water droplet symbol the flow will increase. To decrease the flow, turn the Diverter control knob back towards the OFF setting.

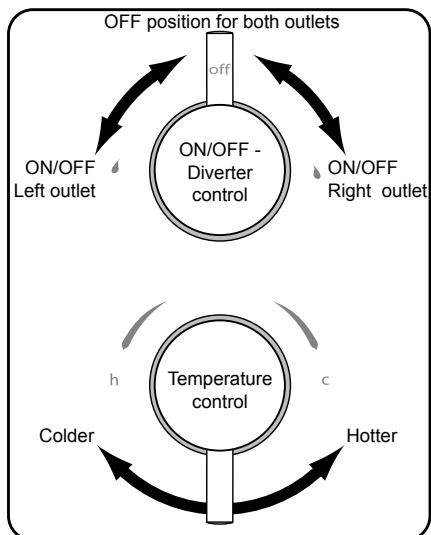
To use the Right outlet turn the Diverter control to the right. As the lever is moved towards the water droplet symbol the flow will increase. To decrease the flow, turn the Diverter control knob back towards the OFF setting.

To stop the water flow reposition the Diverter control knob to the 12 o'clock position.

To adjust the water temperature, rotate the temperature control clockwise for a cooler shower or anti-clockwise for a hotter shower.

**CAUTION:** Exposed metal and chromed surfaces may become hot during use.

Fig.23



## APPROVALS

This mixer valve is approved to the requirements of:

\*On pressures above 0.5 bar.

Designation:

\*BS EN 1111

\*WRAS

HP-S (high pressure shower only)

### TMV2 REQUIREMENTS (12 MONTHLY VERIFICATION)

It is a requirement that all TMV2 approved valves shall be verified against the original set temperature results once a year.

On installation and on a yearly basis please perform the following checks:

#### 1. Cold water supply isolation test

Isolating the cold water supply to the TMV, wait for five seconds if water is still flowing check that the temperature is below **46C**.

If there is no significant change to the set outlet temperature ( $\pm 2^{\circ}\text{C}$  or less change from the original settings) and the fail-safe shut off is functioning, then the valve is working correctly and no further service work is required.

If there is a residual flow during the commissioning or the annual check this is acceptable providing the temperature of the water seeping from the valve is no more than **2C** above the designated maximum mixed water outlet temperature setting of the valve.

#### Note:

Temperature readings should be taken at the normal flow rate after allowing for the system to stabilise.

The sensing part of the thermometer probe must be fully submerged in the water that is to be tested.

## FLOW CHART

Flow Rate (l/m)	5.4	7.0	8.5	10.5	11.5	21.0	23.0	28.5	33.0	37.0
Pressure (bar)	0.1	0.2	0.3	0.4	0.5	1.0	2.0	3.0	4.0	5.0

#### Conditions for test

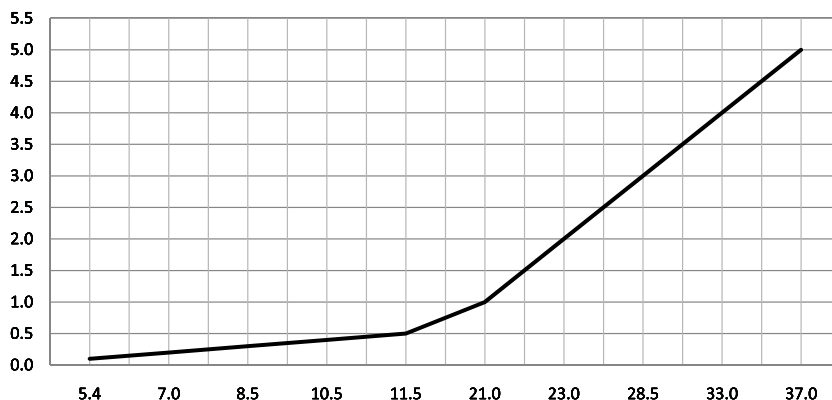
Inlet temperatures comply with EN1111 requirements

Outlet temperature 38°C

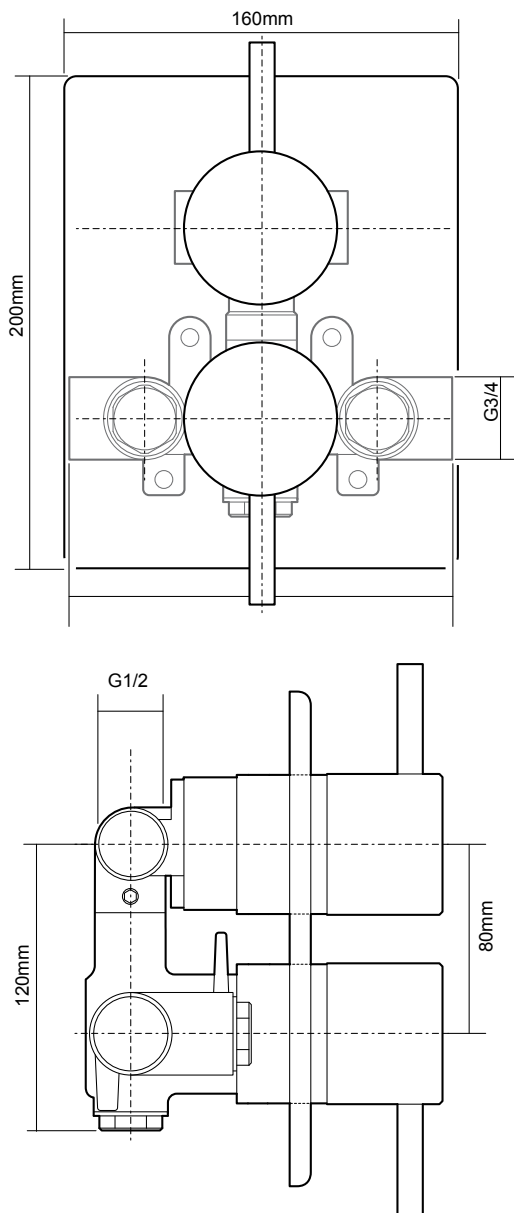
Flow Control Fully Open

Open Outlet - No hose or showerhead connected

### Flow Rate (l/m)

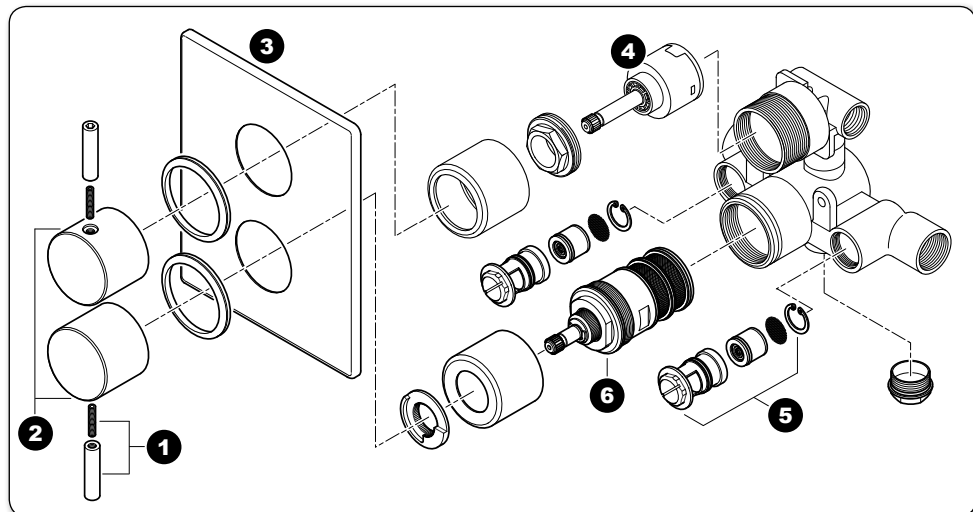


## DIMENSIONS



All dimensions listed in this fitting book regarding the product and installation are approximate.

## SPARE PARTS



<b>Ref.</b>	<b>Description</b>	<b>Part No.</b>
1.	Lever pack X2	83312820
2.	Handle set	86002530
3.	Cover plate & seals	86002610
4.	Diverter outlet	83312920
5.	Check valve assembly	83312900
6.	Thermostatic valve	83312910

## MAINTENANCE

The following maintenance procedure must be carried out for commercial and health care premises, but is not necessarily required for domestic installations.

Maintenance of the unit is required to give continued performance after installation and that it continues to provide scald prevention.

**NOTE:** *A thermostatic mixing valve in need of maintenance can be undetectable in normal use and only becomes apparent when a disruption occurs in the hot or cold water supply temperatures or pressures.*

It is a requirement that all **TMV2** approved valves shall be verified against the original set temperature results **once every 12 months**.

- a) Initially check the filters for debris once every three months and clean if necessary.
- b) Perform a thermal shut off test every three months, and check the maximum temperature setting. See the 'Commissioning' section for the details of this test and readjustment of the maximum temperature setting if required.
- c) If the maximum water temperature varies by more than 2°C from the commissioned setting then carry out the following checks
  - Check the isolating valves are fully open.
  - Check the internal surface for scaling.

If the body requires descaling then it should be removed from the pipework to carry this work out (all rubber parts **MUST** be removed before descaling).

- Check the function of the non-return valves.

The non-return valves (NRVs) prevent cross-flow between hot and cold supplies under unequal pressure conditions. They are designed for long life with no maintenance.

**NOTE:** *the (NRV's) will only operate in one direction - water should be able to flow into the unit from the inlets, but **NOT** back out through the inlets.*

If these checks do not highlight the reason for the temperature variation, then internal components will require replacement - *please see the spare parts list.*

## Cleaning

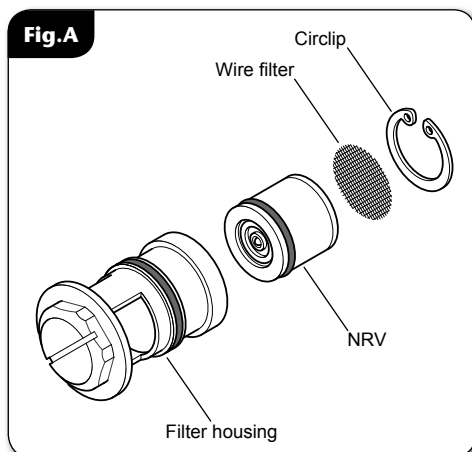
It is recommended that all products are cleaned using warm, soapy water.

Do not use abrasive or aggressive chemical cleaning products as this may affect the product surface finish and invalidate your guarantee.

## Cleaning the filters (fig.A)

It is advised that this should be carried out by a qualified person.

- Turn off the water supplies before starting.
- To gain access to the filters remove the filter housings from the front of the unit.
- Remove the retaining clip and filter.
- Wash the filter thoroughly under running water, use a suitable brush to remove all debris.
- Reassemble in reverse order.



## Disinfection

Where chlorine is used for the disinfection of water systems all relevant guidelines and approved codes of practice must be strictly followed. Failure to comply with the relevant guidelines and approved codes of practice may invalidate your guarantee.

**WARNING!**  
**DO NOT use 'powerful' abrasive or solvent cleaning fluids when cleaning the shower as they may damage the fittings.**

## FAULT FINDING

The following can be carried out by a competent person

<b>Problem/Symptom</b>	<b>Cause</b>	<b>Action/Cure</b>
<b>1</b> Water too hot.	<b>1.1</b> Temperature control incorrectly commissioned.	<b>1.1.1</b> Refer to commissioning section.
	<b>1.2</b> Not enough cold water flowing through shower.	<b>1.2.1</b> Reposition the temperature control.
	<b>1.3</b> Increase in the ambient cold water temperature.	<b>1.3.1</b> Reposition the temperature control.
	<b>1.4</b> Cold water supply blocked.	<b>1.4.1</b> Turn off shower and consult a competent plumber or contact Customer Service.
	<b>1.5</b> High volume of cold water drawn off elsewhere.	<b>1.5.1</b> Reduce the simultaneous demand from the mains supply.
<b>2</b> Water too cold.	<b>2.1</b> Temperature control incorrectly commissioned.	<b>2.1.1</b> Refer to commissioning section.
	<b>2.2</b> Not enough hot water flowing through shower.	<b>2.2.1</b> Reposition the temperature control.
	<b>2.3</b> Decrease in the ambient cold water temperature.	<b>2.3.1</b> Reposition the temperature control.
	<b>2.4</b> Insufficient hot water supplies from the heating system.	<b>2.4.1</b> Make sure heating appliance is set to maximum or has sufficient stored hot water.
		<b>2.4.2</b> Make sure heating appliance is igniting by trying a hot water tap elsewhere.
<b>2.5</b> Hot water supply blocked or restricted.	<b>2.5.1</b> Turn off shower and consult a competent plumber or contact Customer Service.	
<b>3</b> High water flow and/or poor performance on a mains fed system.	<b>3.1</b> Flow regulators not fitted.	<b>3.1.1</b> Fit the supplied flow regulators in the inlet elbows (see 'To fit a flow regulator' on page 13).

## FAULT FINDING

<b>Problem/Symptom</b>	<b>Cause</b>	<b>Action/Cure</b>
<b>4</b> Water does not flow or shower pattern collapses when another outlet is turned on.	<b>4.1</b> Water supplies cut off.	<b>4.1.1</b> Check water elsewhere in house and if necessary contact local water company.
	<b>4.2</b> Shower unit blocked.	<b>4.2.1</b> Inspect the filters. Clean if necessary.
	<b>4.3</b> Blockage in pipework.	<b>4.3.1</b> Turn off the shower and consult a suitably competent plumber.
	<b>4.4</b> Showerhead blocked.	<b>4.4.1</b> Clean the showerhead.
	<b>4.5</b> System not capable of supplying multiple outlets at the same time.	
		<b>4.5.3</b> Check if there is sufficient water pressure.

**The following is recommended for a professional qualified installer only**

<b>5</b> Water too cold.	<b>5.1</b> Running pressure is excess of maximum recommended.	<b>5.1.1</b> Fit a pressure reducing valve.
<b>6</b> Shower controls noisy when in use.	<b>6.1</b> Running pressure in excess of maximum recommended.	<b>6.1.1</b> Fit a pressure reducing valve.
<b>7</b> Shower will not shut off.	<b>7.1.</b> Pipework not flushed out before connecting to the unit. Internal components damaged.	<b>7.1.1</b> Service valve.



**COMMISSIONING, MAINTENANCE and IN-SERVICE TESTING RECORD**

Where installed: \_\_\_\_\_

Mixer valve location: \_\_\_\_\_

Date installed: \_\_\_\_\_ Installed by: \_\_\_\_\_

**Commissioning details:** Hot water - Temp: \_\_\_\_\_ °C Pressure: \_\_\_\_\_ Bar

Cold water - Temp: \_\_\_\_\_ °C Pressure: \_\_\_\_\_ Bar

Maximum temperature setting - Temp: \_\_\_\_\_ °C Pressure: \_\_\_\_\_ Bar

**Equipment used:**

\_\_\_\_\_  
\_\_\_\_\_  
\_\_\_\_\_

**Inspection and maintenance record:**

\_\_\_\_\_  
\_\_\_\_\_  
\_\_\_\_\_  
\_\_\_\_\_  
\_\_\_\_\_  
\_\_\_\_\_  
\_\_\_\_\_  
\_\_\_\_\_  
\_\_\_\_\_  
\_\_\_\_\_  
\_\_\_\_\_





## UK SERVICE POLICY

In the event of a product fault or complaint occurring, the following procedure should be followed:

1. Telephone Customer Service on **024 7637 2222** having available, your details including post code, the model number and power rating of the product, together with the date of purchase and, where applicable, details of the particular fault.
2. If required, the Customer Service Advisor will arrange for a qualified engineer to call.
3. All products attended to by a Triton service engineer must be installed in full accordance with the Triton installation guide applicable to the product. (Every product pack contains an installation guide, however, they can also be downloaded free at [www.tritonshowers.co.uk](http://www.tritonshowers.co.uk)).
4. Our engineer will require local parking and if a permit is required this must be available to the engineer on arrival at the call.
5. It is essential that you or an appointed representative (*who must be over 18 years of age*) is present for the duration of the service engineer's visit. If the product is in guarantee you must produce proof of purchase.
6. Where a call under the terms of guarantee has been booked and the failure is not product related (*i.e. scaling and furring, incorrect water pressure, pressure relief device operation or electrical/plumbing installation fault*) a charge will be made. A charge will also be issued if nobody is at home when the service engineer calls or adequate parking/permit is not available.
7. If the product is no longer covered by the guarantee an up front fixed fee will be charged before the site visit.
8. Should proof of purchase not be available on an "in-guarantee" call, or should the service engineer find that the product is no longer under guarantee, the engineer will charge the same fixed price and the customer will be expected to pay the engineer before he leaves. If payment is not made on the day an administration charge will be added to the fixed charge.
9. If a debt is outstanding from a previous visit, or from any other Triton purchase, Triton reserves the right to withhold service until the debt has been settled.
10. Triton takes the health, safety and wellbeing of its employees very seriously and expects customers to treat all staff members with respect. Should any employee feel threatened or receive abuse, either verbally or physically, Triton reserves the right to withhold service and will support the employee with a legal prosecution.

### Replacement parts policy

1.1. It is the policy of Triton Showers to maintain parts availability for the duration of production and a period of 5 years thereafter in accordance with industry standards. Spare parts can be ordered via our online spare parts store, or by telephoning Triton Customer Service Spares Department on 024 7637 2222. Payment should be made by credit / debit card (excluding American Express or Diners Card). Payment can also be made by pre-payment of a pro-forma invoice, by cheque or postal order.

**1.2. Telephone orders are based on information given during the call. Before contacting Triton, please verify your requirements using the information contained in the user guide. Triton cannot accept liability for incorrect part identification.**

## TRITON COMMERCIAL GUARANTEE

With the exception of accessories, Triton guarantee the product against all manufacturing defects for a period of **3 years** (from the date of purchase) provided that it has been installed by a competent person in full accordance with the fitting instructions.

All accessories such as shower heads, hoses and riser rails carry a **1 year** parts only guarantee against manufacturing defects.

Any part found to be defective during this guarantee period we undertake to repair or replace at our option without charge so long as it has been properly maintained and operated in accordance with the operating instructions, and has not been subject to misuse or damage.

This product must not be taken apart, modified or repaired except by a person authorised by Triton. This guarantee applies only to products installed within the United Kingdom and does not affect your statutory rights.

### What is not covered:

1. Breakdown due to: **a)** use other than domestic use by you or your resident family; **b)** wilful act or neglect; **c)** any malfunction resulting from the incorrect use or quality of electricity, gas or water or incorrect setting of controls; **d)** failure to install in accordance with this installation guide
2. Claims for missing parts once the product has been installed.
3. Repair costs for damage caused by foreign objects or substances.
4. Total loss of the product due to non-availability of parts.
5. Compensation for loss of use of the product or consequential loss of any kind.
6. Call out charges where no fault has been found with the appliance.
7. The cost of repair or replacement of pressure relief devices, showerheads, hoses, riser rails and/or wall brackets, isolating switches, electrical cable, fuses and/or circuit breakers or any other accessories installed at the same time.
8. The cost of routine maintenance, adjustments, overhaul modifications or loss or damage arising therefrom, including the cost of repairing damage, breakdown, malfunction caused by corrosion, furring,
9. Call out charges where the water supply cannot be isolated, this includes consequential losses arising from unserviceable supply valves.

**For the latest Terms & Conditions, please see:  
[www.tritonshowers.co.uk](http://www.tritonshowers.co.uk)**

Triton Showers  
Triton Road  
Nuneaton  
Warwickshire  
CV11 4NR

*Triton is a division of Norcross Group (Holdings) Limited*

**Customer Service: 024 7637 2222**  
**Trade Installer Hotline: 024 7637 8344**  
**Fax: 024 7632 4504**

**[www.tritonshowers.co.uk](http://www.tritonshowers.co.uk)**  
**E-mail: [serviceninquiries@tritonshowers.co.uk](mailto:serviceninquiries@tritonshowers.co.uk)**  
**[technical@tritonshowers.co.uk](mailto:technical@tritonshowers.co.uk)**