

AX310 / AX311 Shower Handbook

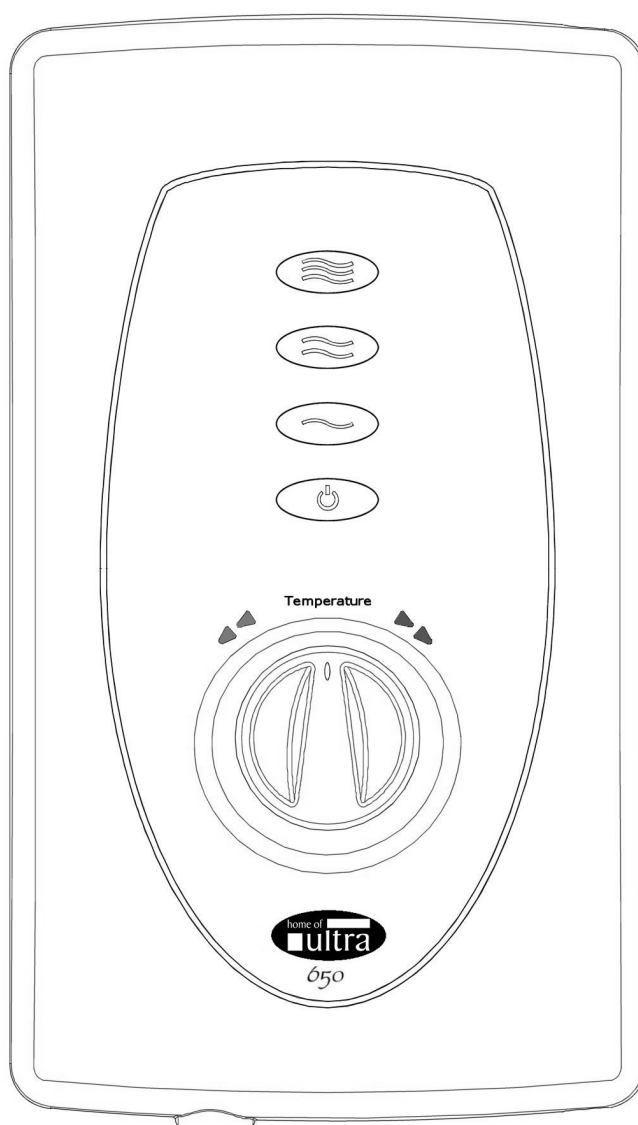

IMPORTANT:
Please retain this booklet for future reference

CONTENTS

	Page
How to use your shower	2
How your shower works	3
What to do if things go wrong	5
Installation instructions	6
How to maintain your shower	10
Guarantee	12

How to use your shower

Diagram 1

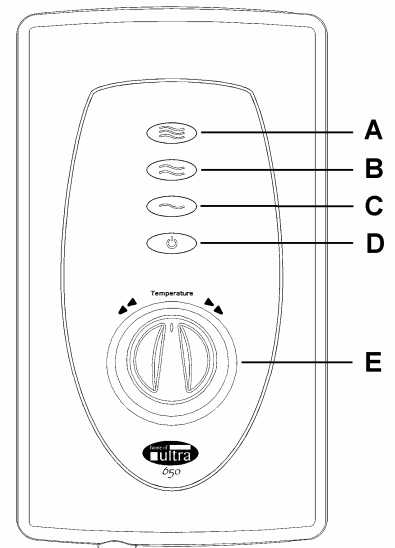

1. Ensure the electricity and water are turned on to the unit
2. Function of buttons: -
 - Button 'A'** – Starts shower on '**HIGH**' giving maximum power.
 - Button 'B'** - Starts shower on '**MEDIUM**' giving economy setting.
 - Button 'C'** - Starts shower on '**COLD**' giving water with no heating.
 - Button 'D'** – '**Shutdown**' switches the shower off and cools the water automatically.

Your shower has 3 power settings selected by pushing the corresponding button on the front cover.

It can be started by pressing 'A', 'B' or 'C' buttons. Once pressed, a light will illuminate above the button confirming that power selection has been made.
3. Once either '**A (HIGH)**' or '**B (MEDIUM)**' have been pressed you will need to adjust the temperature of the water. This is done by rotating knob 'E'.
If this is **too low then turn the knob anti clockwise** and allow 20 seconds for the temperature to settle. Repeat this procedure until the temperature is to your liking.
4. If the temperature is **too high then turn knob 'E' clockwise** allowing 20 seconds between adjustments. See diagram 3 for relationship of flow to temperature.
The final adjustment can be anywhere on the scale.
5. Once a temperature setting to your liking has been achieved knob 'E' will rarely need adjusting.
e.g. Adjust for variations of incoming mains water temperature between summer and winter.
6. When you have **finished** showering, **push button 'D' only**. The electricity to the elements is then disconnected and the adjacent light will flash, water will continue to flow for approximately 5 seconds before switching off. This reduces the temperature of the water in the unit. Switch the electricity off at the ceiling switch or local isolator.
7. Your shower is designed to stabilise temperature changes caused by water pressure fluctuations. These can result from toilets being flushed or taps being turned on or off. When this happens your showering temperature will be held within a controlled band, provided that the minimum pressure required by the shower is maintained.
8. Your shower requires a minimum operating pressure of 100 kPa (1.0 bar, 14.5 p.s.i.).
At pressures above 100 kPa (1.0 bar, 14.5 p.s.i.) it will minimise temperature fluctuations as detailed in note 7.
If the water pressure falls below 100 kPa (1.0 bar, 14.5 p.s.i.), it is likely that the pressure switch will turn off the power to the heating elements, resulting in a cold shower.
9. During normal operation if the shower senses an overheated water temperature then the thermal cutout will switch off the heating elements. Water will continue to flow and as the water temperature falls the heating elements will be turned back on. If the unit continues to cycle then increase the flow rate by turning knob 'E' clockwise and check that the handset does not require de-scaling. If it still continues to cycle then press button 'B' to the '**MEDIUM**' power setting. (Knob 'E' will need adjusting).
10. Note that knob '**E IS NOT A TAP**' and does not turn the water off.

**WARNING! DO NOT SWITCH THE SHOWER ON IF YOU SUSPECT IT OF BEING FROZEN.
WAIT UNTIL YOU ARE SURE IT HAS THAWED OUT.**

After Sales Service

Remember to quote the exact type of shower, as written on the front face. The model and serial number are located on the bottom face of the shower. Make a note of those numbers, and quote them if you call for advice.

Model No: 53-..... / Serial No:.....

Note: You may be charged for a service call if you do not have a serial number.

How your shower works

Your shower is designed for convenience, economy and safety of use

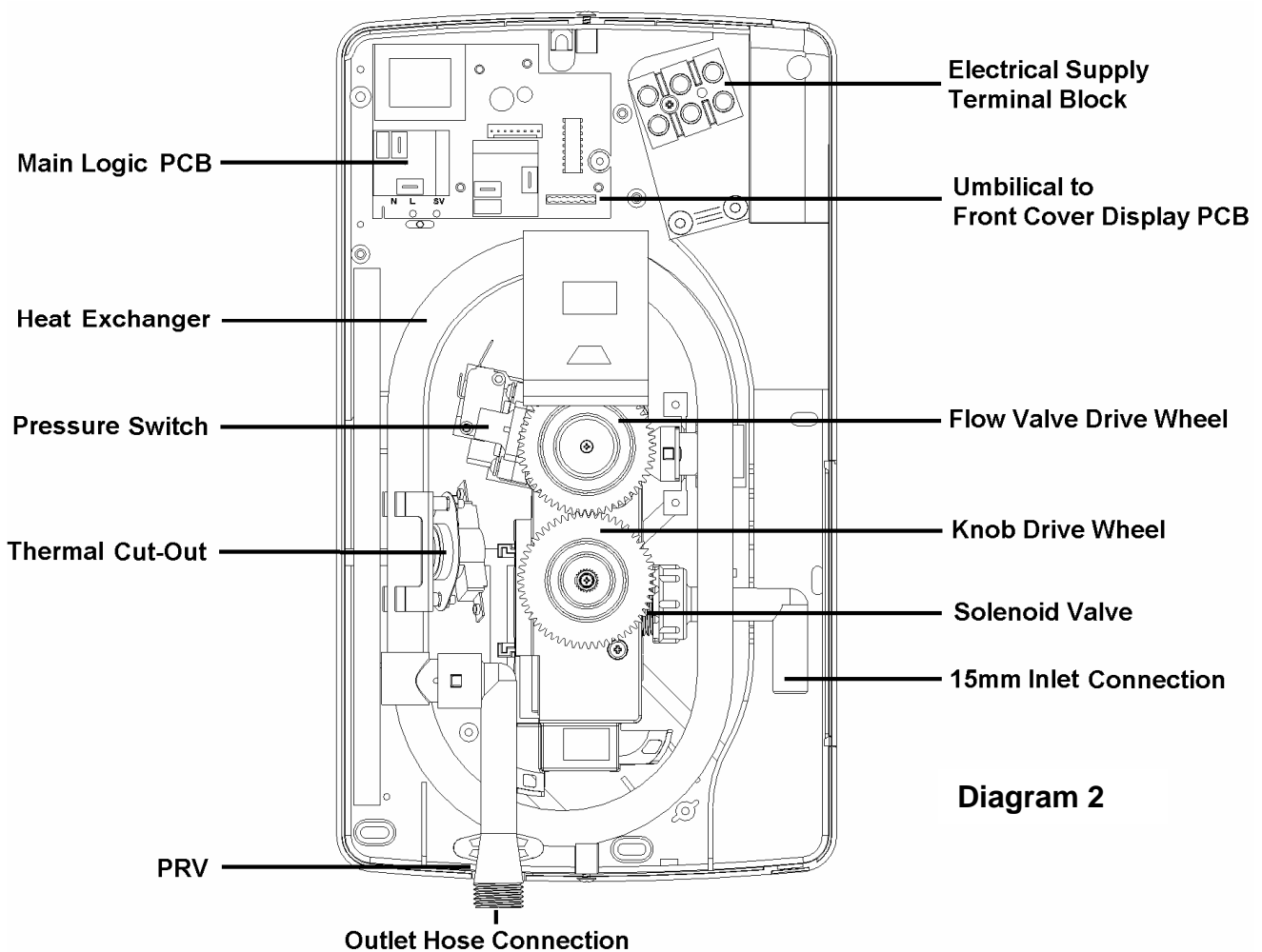
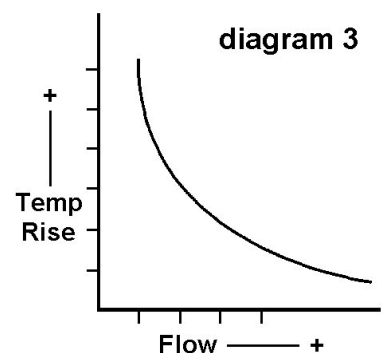

Diagram 2

1. Water is heated instantaneously as it flows over the heating elements in the copper heating tube. (Diagram 2).

2. The required water temperature is achieved by adjusting the rate of water flow. Diagram 3 shows the principle involved in relating temperature rise to flow rate. The higher the water flow the lower the temperature rise, and vice versa. The temperature of the water supplied from the mains can vary considerably throughout the year from 5 to 20°C. This means that in Winter, the flow rate will be less than in the Summer to achieve the same outlet temperature. In Summer the 'MEDIUM' power setting may give adequate hot water.



3. The heaters are only switched on when sufficient water is flowing.
This is done automatically with a switch, which works on water pressure.
4. The water is turned on and off by the solenoid valve built into the shower.
This is switched on by button 'A', 'B' or 'C'. (diagram. 2)
5. The flow of water is automatically held at the level set by the user even though the supply pressure may vary. (See 'How to use your shower' note 7).
6. If the water supply falls below a set limit, the pressure switch will operate and switch off the power to the elements.
7. As a further safeguard, a thermal cutout switches the power off if the water temperature climbs above a set limit. The cutout gives an audible click when it switches off, but will reset itself if water is run through the shower for 10 to 20 seconds.
8. The pressure relief device is to safeguard against extreme abuse conditions and provides a level of appliance protection should an excessive build of pressure occur within the shower.
9. There are a number of defined spray plate settings modes (patterns) adjustable by rotating the spray plate (see diagram 4).
The modes (patterns) have a positive "click" to identify them.
The spray plate rotates through a full circle (360°) in either direction.

IN ORDER TO MAINTAIN THE PERFORMANCE OF YOUR SHOWER YOU MUST CLEAN THE SHOWERHEAD.

All water contains particles of lime-scale, which build up in the showerhead and unit reducing the performance.

It is therefore important to regularly clean the showerhead by simply rubbing the rubber nozzles, or soaking in proprietary lime-scale remover and rinsing thoroughly before use.

The frequency of this will vary from weekly to quarterly depending on the water hardness and experience.

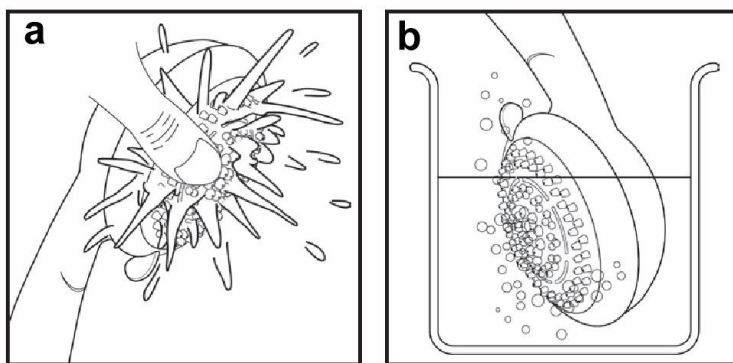

In some winter conditions, when the incoming mains water is particularly cold it may be necessary to select the inner or outer spray pattern only. This will ensure correct operation of the shower with a slightly lower water flow rate

Note: After use it is normal for some water to drip from the showerhead for a few moments, this inhibits scale build up over prolonged use.

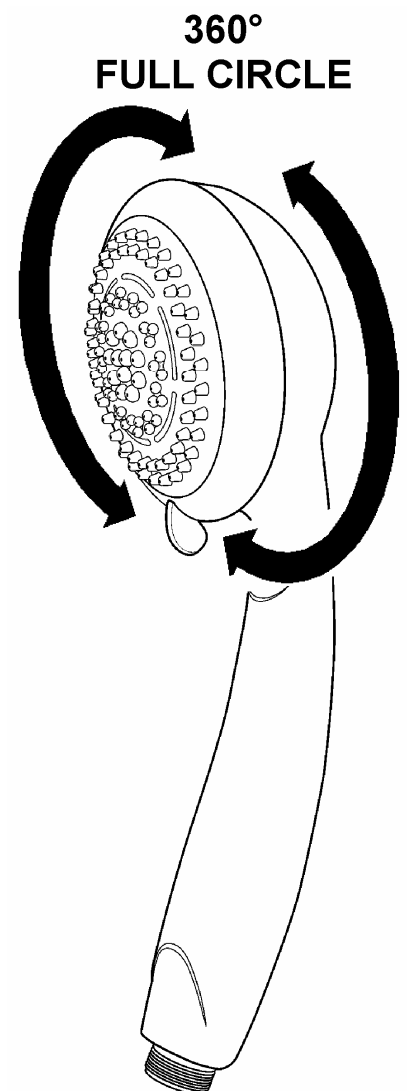

What to do if things go wrong

SELF HELP

If the shower is not working satisfactorily, make the following checks before calling out the contractor. Any of these adjustments could restore the performance

a) The shower cycles from HOT to COLD	The shower temperature is set too hot causing the thermal cut-out (safety device) to operate. Turn the temperature knob fully clockwise to increase the water flow. MEDIUM setting may need to be selected. Slowly increase the water temperature by turning knob anti-clockwise until a comfortable showering temperature has been reached. You MUST WAIT approximately 20 seconds for each adjustment to affect the water temperature.
b) Water too HOT	Increase water flow by adjusting the temperature control clockwise. Clean spray plate holes. Select outer or combination spray patterns. Switch power to MEDIUM setting. Increase pressure of water supply e.g. fully open service valve or stop cock. Check hose is not kinked restricting the water flow.
c) Water too COLD	Decrease water flow by adjusting the temperature control anti-clockwise. Select inner or outer spray patterns only. Switch power to HIGH setting.
d) Spray pattern poor	Clean spray plate and flush heater with handset removed. Select inner / outer spray pattern.
e) Water goes cold while using shower	Check power setting lights are on Check water pressure has not fallen so far as to let pressure switch cut out, e.g. another tap drawing water off. Raise position of handset.
f) Broken parts	Please contact our spares department on 0844 372 7750. Fitting instructions are provided with spares.

PROFESSIONAL SERVICE

If the previous checks fail to restore the performance, you should either contact the Technical Advisory Service or seek the assistance of a qualified plumber and / or electrician.

The person who installed the shower is probably the best one to repair it and is certainly the person to contact if you have a problem in the guarantee period.

The following additional checklist is provided for the benefit of the qualified serviceman.

WARNING – SWITCH OFF THE ELECTRICITY AT THE ISOLATING SWITCH BEFORE REMOVING THE COVER TO MAKE CHECKS.

a) Water too HOT	Water flow restricted by blockage in filter of solenoid valve. Switch off water and undo plastic nut on elbow, loosen brass nut to swing elbow away from solenoid. Remove filter in solenoid with long nosed pliers and flush clean.
b) Water too COLD	Check circuit through thermal cut-out Check circuit through microswitch on the pressure switch Check each element circuit. Check tightness of electrical connections.
c) Water discharge from pressure relief valve	Check for cause of high pressure and remove it. Blockage on outlet i.e. blocked spray plate. Replace the pressure relief disc (not covered by guarantee).
d) Water does not flow when button 'A', 'B' or 'C' is pressed	Ensure flying lead from the PCB has been connected to the front cover. Check the circuit through the solenoid coil. Check circuit through microswitch Possible PCB fault, if defective, then replace. Power supply not reaching shower.

Installation instructions

Check that the electrical rating shown on the showers matches the mains supply.

A competent installer must undertake all installations.

If in any doubt, advice and assistance should be sought from a qualified plumber and/or electrician.

Installations and wiring must conform to current BS7671 (IEE regulations - UK) and "Part P" of the Building Regulations.

WARNING! DO NOT INSTALL THIS SHOWER IN A ROOM WHERE IT MAY BE SUBJECT TO FREEZING

We recommend that the installation be done in the following sequence.

- a) Fixing the shower to the wall
- b) Plumbing
- c) Electrical connections

a) Fixing the shower to the wall

1. Position the riser rail at a convenient height for majority of users as recommended in diagram 5 and mark its position.
2. Position the heater so the sides of the unit are vertical and the top is level with, or up to 0.6 metres (2ft) maximum below the top of the riser rail. Choose a flat piece of wall to avoid the possibility of distorting the back plate thus making the front cover a poor fit.
3. Adjust the positions to get the most convenient arrangement taking the following into account.
 - a) The possible need to use the handset over the sink for hair washing etc.

Diagram 5

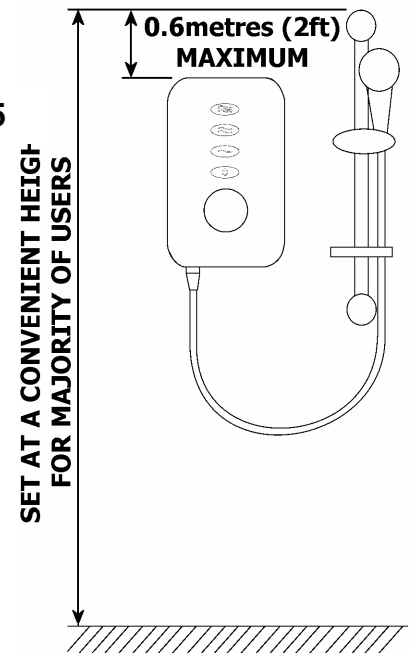

b) The heater must not be mounted in the direct spray from the showerhead.

- c) The handset must not be able to come into contact with any used water in the bath or basin. If it can, even after the hose has been retained by the hose retainer (see diagram 13), then a vacuum breaker must be fitted. It should be noted that these devices are liable to minor leakage so they must be positioned so that any drips are not detrimental.
4. Fix the riser rail with screws provided. The fixing holes at the base of the brackets will be disclosed by removing the plastic fronts. Assemble as shown in diagram 13.

Diagram 6

5. Decide the position of the electrical cable inside the unit. If top or bottom entry is chosen (according to diagram 6), cut away the walls of the back-plate as shown in diagram 8. There is also the option to fit the cable from the rear in the channel provided.
6. Decide the cut away position of entry of the cold water pipe into the unit. Cut away the back-plate and front cover as shown in diagram 7 or 8.

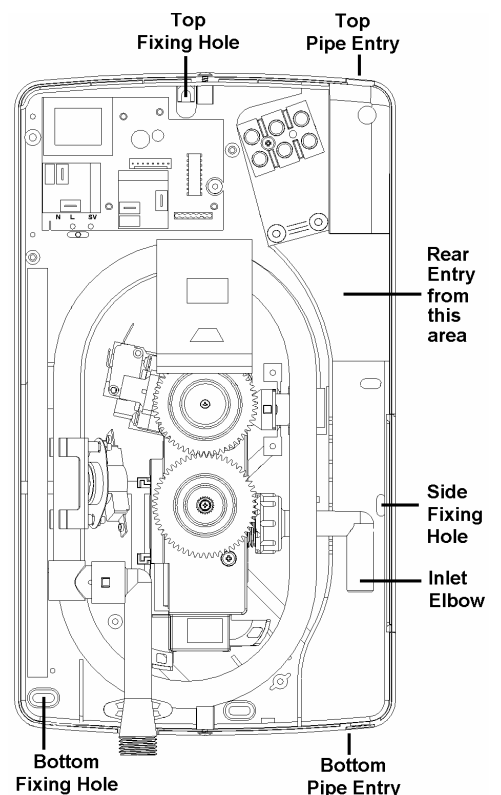

There is also the option to have rear entry (see later section on plumbing).

- If you have not yet done so, remove the front cover (complete with control knob) of the unit by undoing the retaining screws at the top and bottom of the unit and lifting the cover off. The top-fixing hole is a keyhole slot, and should be marked and drilled first. Tighten top screw with head protruding about 10mm from wall and hook the back-plate over the screw head. This allows for correct and accurate alignment of your shower before marking and fixing the bottom/side position. You may not wish to tighten up all 3 screws at this stage as the holes are elongated to allow for adjustment after other connections have taken place.

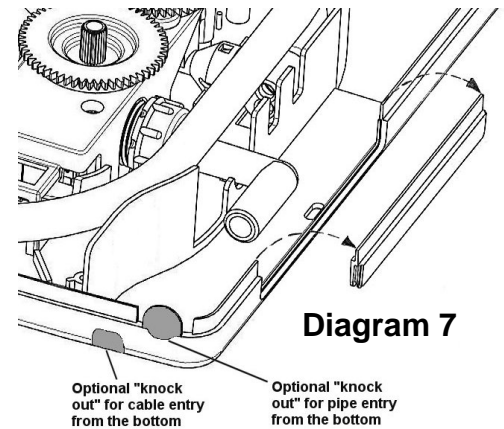

WARNING! TAKE CARE NOT TO DAMAGE THE PRINTED CIRCUIT BOARD IN ANY WAY. DURING INSTALLATION AVOID DUST AND DEBRIS GETTING ON IT.

Diagram 8

- Do not obstruct the pressure relief device found in the back-plate slot underneath the outlet connection (see diagram 3). Especially if silicone sealant or similar materials are used around the edges of the back-plate.
- There are a number of clearly marked shields in the shower unit. These are important for the correct operation of this shower and **MUST NOT** be removed under any circumstances.

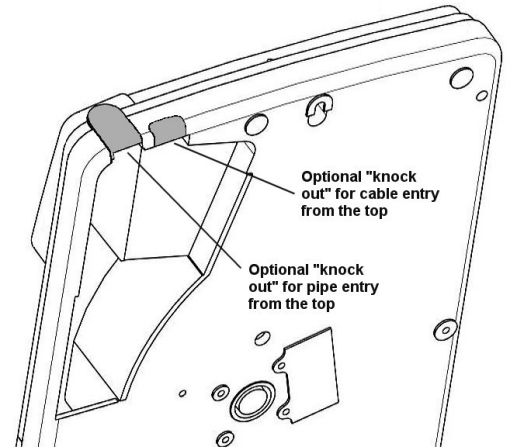

b) Plumbing (see diagram 9)

The heater should be connected to the mains cold water supply.

This must have a minimum running pressure of 100kPa (1.0 bar, 4.5 p.s.i) and a maximum pressure of 1000kPa (10 bar, 145 p.s.i).

Before connecting the pipe-work to the shower ensure that pipe-work is flushed out.

- It is recommended that a WRAS (Water Regulations Advisory Scheme) listed isolating valve is fitted between the rising main and the unit. This will allow the unit to be serviced without turning off the cold water or exchanged without having to turn off the water at the water mains stop valve.
- The heater can be fed from a header tank provided this has a minimum head height of 10.5 metres (35ft).
- Ø15mm copper or stainless steel pipe should be used with a standard compression fitting. In multiple shower installations correct pipe-work sizes should be calculated to maintain adequate flow to each shower.
- If top entry is chosen, turn the elbow 180° into the required position and fit a standard 15mm in line compression fitting. There is a removable side section, which will aid you with this (diagram.7).
 - If rear entry is chosen, turn the elbow 180° and treat it as top entry except for the fitting of a 'Yorkshire' elbow in the rear channel. The removable side section will again be an aid.
- It is permissible to use a WRAS (Water Regulations Advisory Scheme) approved sealant sparingly whilst avoiding excess finding its way into shower operating parts.

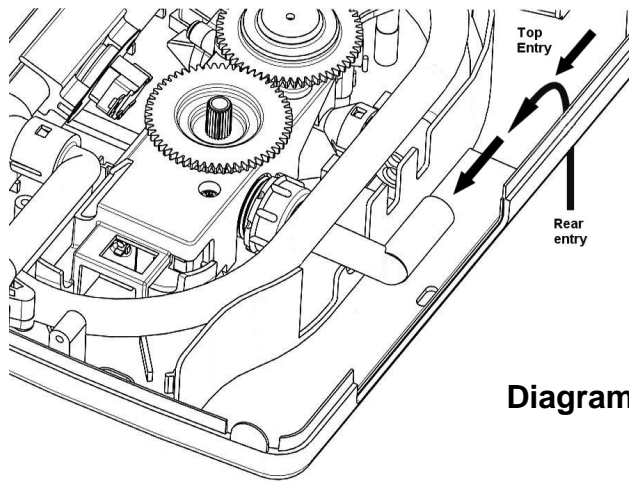
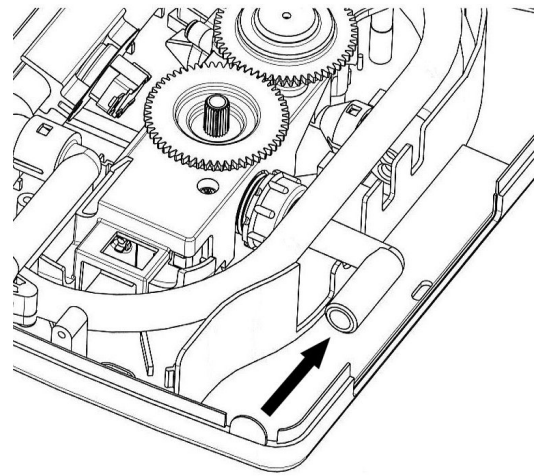

Diagram 9



6. With the stop valve connected, **flush the pipe-work through to remove any particles etc.**, before making the final connection to the shower. Blockage in the waterways (particularly the handset and solenoid valve) will prevent the heater working properly.
7. The shower is designed to have an open outlet and should only be used with fittings recommended by the manufacturer. Do not connect the showerhead until after the shower front cover and removable side section are fitted.

**WARNING - DO NOT FIT A TAP ON THE SHOWER OUTLET.
TAKE CARE TO AVOID RESTRICTING THE OUTLET AND FLOW
FROM THE SHOWERHEAD OR THE PRESSURE RELIEF DEVICE.**

d) Electrical Connections

The electrical installation must be in accordance with the current BS. 7671 (IEE regulations) and "Part P" of the Building Regulations. If in doubt consult a qualified electrician.

1. The shower is designed for a single-phase A.C. electrical supply. Please check the rating plate on the unit to see what details apply.
2. The table is to be used as a guide only. Please refer to the current wiring regulations

Rating	Cable Sizes	Fuse/ MCB
9.5 / 8.7kW 240 / 230V	10mm ²	40 or 45A Cartridge fuse /MCB
10.5 / 9.6kW 240 / 230V	10mm ²	45A Cartridge fuse / MCB

For the 9.5kW you may be able to use 6mm² cable if Method 1 (clipped direct) is used. Remember to uprate the cable if it runs in thermal insulation in a loft, or for longer distance

3. A means for disconnection in all poles must be incorporated in the fixed wiring in accordance with the wiring rules. We recommend a ceiling switch mounted in a convenient position.
4. Cut back cable as in diagram 10. Connect cable to terminal block making sure that ALL the retaining screws are VERY tight and that no cable insulation is trapped in the block.

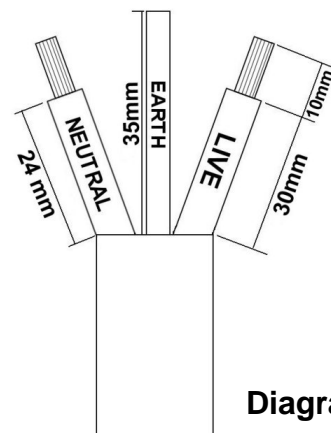
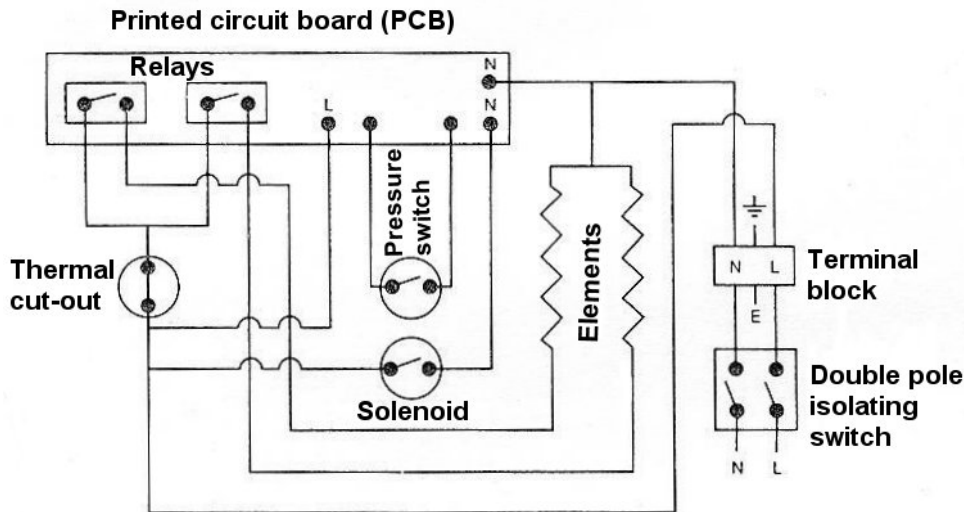

Diagram 10



Schematic Wiring Diagram

WARNING - FAILURE TO COMPLY WITH THESE INSTRUCTIONS COULD RESULT IN A FAILURE OF THE TERMINAL BLOCK AND CABLING.

5. **WARNING - THIS APPLIANCE MUST BE EARTHED.**
6. Ensure that the removable side section is fitted securely into the back-plate.
7. Re- connect cable to front cover PCB (one way fit) see diagram 11.
8. Fit the front cover back into position making sure the knob is aligned correctly with the flow valve (see diagram 12).

WARNING - TAKE CARE WHEN REPLACING THE FRONT COVER TO AVOID DAMAGING ANY COMPONENTS.

9. Operate the shower first without the handset to flush out particles, fit handset and then operate the shower as explained previously and check:
 - a) That the water gets to a satisfactory temperature.
 - b) Power selection does give a change in water temperature.
 - c) Check again for leaks.
 - d) That the holes in the spray plate are not blocked.
 - e) Water flow can be adjusted by knob E

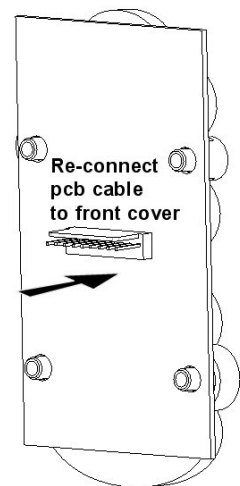

Diagram 11

10. DEMONSTRATE OPERATION TO USER
11. LEAVE THESE INSTRUCTIONS WITH THE USER FOR FUTURE REFERENCE.

This appliance is not intended for use by persons (including children and the infirm) with reduced physical, sensory or mental capabilities, or lack of experience and knowledge, unless they have been given supervision or instruction concerning use of the appliance by a person responsible for their safety.

Children should be supervised to ensure that they do not play with the appliance.

How to maintain your shower

It is recommended that the shower unit, riser rail, hose etc. can be cleaned using a soft cloth and that the use of an abrasive or solvent based cleaning fluid be avoided. This is especially the case on any plated finishes. Micro fibre clothes are recommended for cleaning the chrome.

We recommend that before cleaning, the isolating switch be turned off, thus avoiding accidentally switching on the shower.

The showerhead should be periodically cleaned as previously detailed.

WARNING - YOU MUST REGULARLY INSPECT THE SHOWER HOSE FOR WEAR AND DAMAGE. REPLACE IF NECESSARY, OR EVERY TWO YEARS, WITH OUR APPROVED PART.

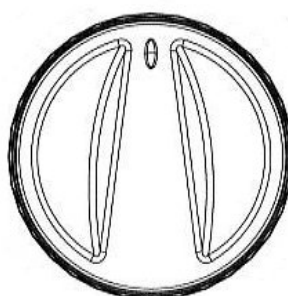

Rotate knob so pointer is as shown

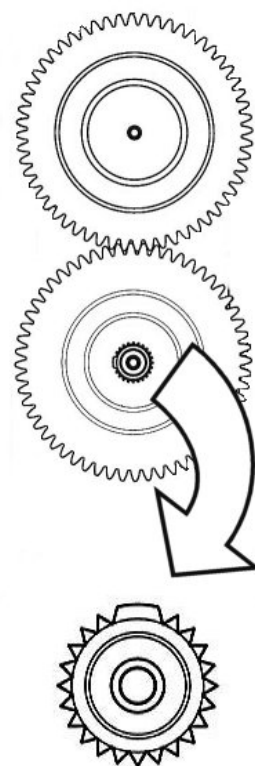

Rotate lower gear so drive is as shown

Diagram 12

Additional Accessories

White 2 metre Shower hose
WRAS Listed Water Isolating Valve
Shower de-scaling powder
Curtain and rail pack
Curtain and rail pack with non-slip Bath mat

Catalogue Number

83-792578
93-792452
95-711015
83-792802
83-792801

Spares *(The fitting of Spare Parts should be supervised by a suitably qualified person)*

Chrome 1.25m Shower Hose 93-797641
Plated control knob (plated version) 93-593590
Gear drive 93-593591
Outlet elbow assembly complete. 93-593592
Removable side section (grey) 93-593593
Removable side section (white) 93-591819

Spares / accessories can be supplied against any Visa or Access cards from the Sales Hotline: Tel 0844 372 7750 / Fax 0844 372 7760.

Diagram 13

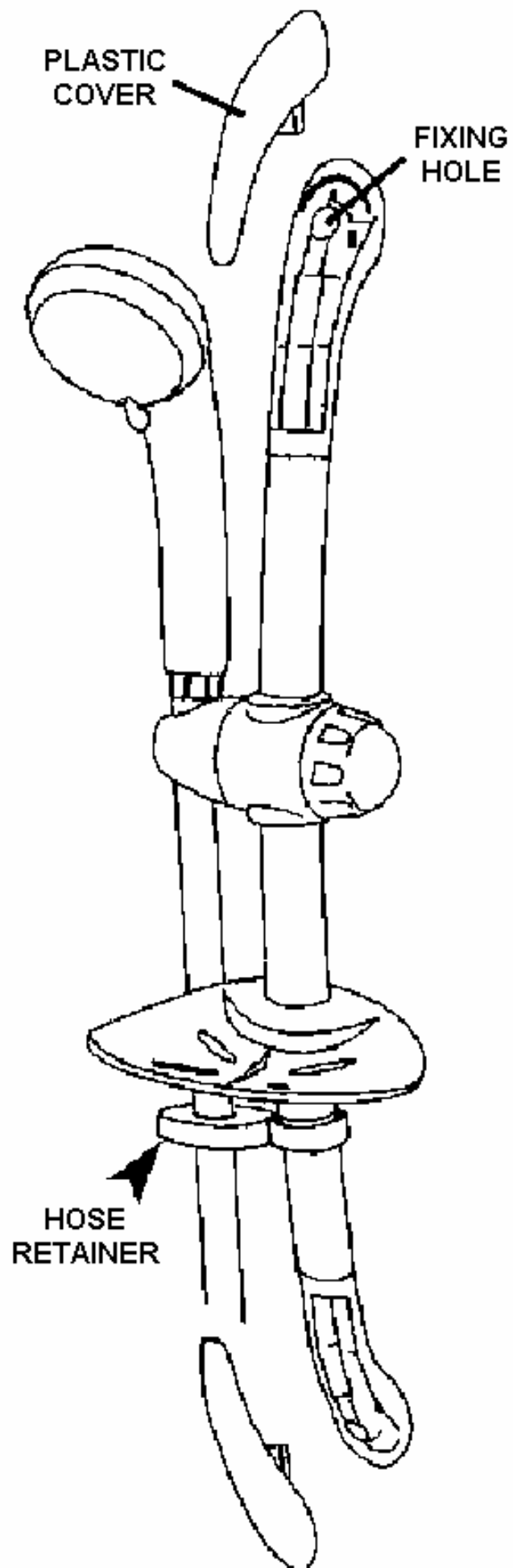

GUARANTEE

We, Ultra Finishings Limited, guarantee this product **for domestic use only**, for the period of 24 months from date of purchase.

Within the guarantee period we will resolve, **free of charge**, any manufacturing defects in the product resulting from faulty workmanship or material on the condition that:-

- a) The appliance has been correctly installed in accordance with our instructions and is being used on the supply circuit or voltage printed on the rating plate.
- b) The appliance has been used in accordance with these instructions and has not been tampered with or otherwise subject, neglect or accident.
- c) The appliance has not been taken apart, modified or repaired except by a person authorised by us.
- d) Evidence of the date of purchase in the form of an invoice or receipt will be required in order to qualify for an in-guarantee repair.
- e) The guarantee period for the products used in commercial applications will be limited to 12 months.
- f) For the service work to be undertaken free of charge, the work must only be undertaken by Ultra Finishings Limited, or our approved agents.
- g) Service under guarantee has no effect on the expiry date. The guarantee of any exchanged parts or product ends when the original guarantee period ends.

EXCLUSIONS

This guarantee **DOES NOT** cover damage or defects arising from poor or incorrect installation, improper use or lack of maintenance, including build-up of limescale. It is the responsibility of the installer to check that the installation parameters meet the requirements of the product, and any relevant regulations.

If we are called out to a fault, which is subsequently identified as being an installation fault, we will make a charge. It is important that the routine checks are completed before calling us out, as many issues can be simply diagnosed and resolved.

We make no guarantees as to response times for repairs. We will endeavour to achieve the most timely response possible but while we indicate an average response time, this should not be taken as a guarantee.

The guarantee applies to a repair or replacement (at our discretion) of the product subject to the conditions above, and **DOES NOT** cover compensation for the loss of the product or consequential loss of any kind.

The guarantee does not apply to the repair or replacement of pressure relief devices, sprayheads, hoses, accessories, isolating switches, electrical cable, fuses and/or circuit breakers.

This guarantee does not affect your statutory rights.

Manufactured in England for:-

ULTRA FINISHING LIMITED
WIDOW HILL ROAD, HEASANDFORD INDUSTRIAL ESTATE, BURNLEY, LANCS, BB10 2BE
TEL: 01282 436934 / FAX: 01282 428915
Technical Advice Line: 0844 372 7766
Website: www.ultra-group.co.uk



(A4 Leaflet No. 555-2066-47A)