



500 / 600 W.C. UNIT

PLEASE READ. Carefully open the packs supplied and check the contents against the Panels and Fittings Checklist before discarding any packaging. Lay panels on smooth level surface using outer packaging to protect the finish. To maintain the appearance of the units dust regularly with a soft cloth. For grime stains wipe with soft damp cloth using a mild detergent.



NOTE: Any additional components left after assembly maybe required for installation-do not discard.

CAUTION: Some Fittings are small enough to choke a child.

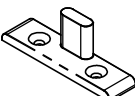
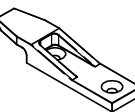
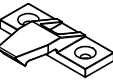
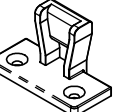
1.	End Panel (Right)	1
2.	End Panel (Left)	1
3.	Top Panel	1
4.	Plinth	1
5.	Back Rail	2
6.	Bottom Fascia	1
7.	Top Fascia	1

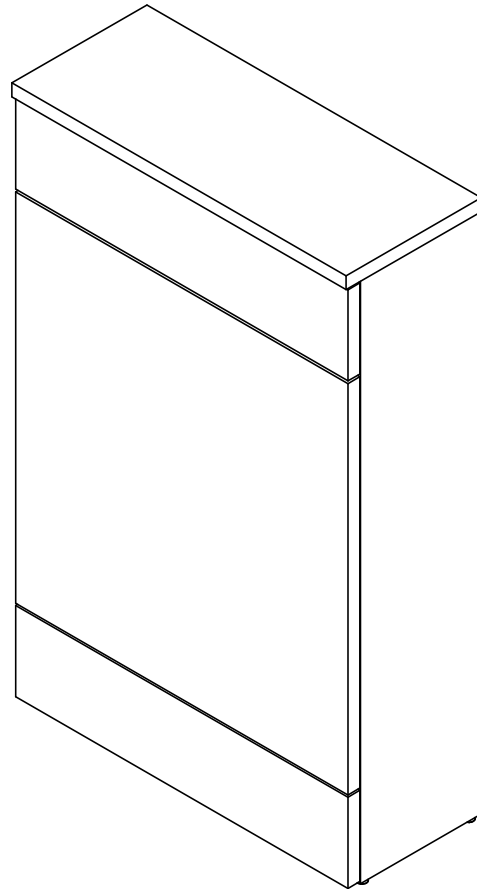
8.		Cam	6
9.		Cam Pin	6
10.		5mm Dowel	12
		8mm Dowel	4
11.		Fascia Bracket (Male)	4
12.		Fascia Bracket (Female)	4
13.		Front Access Bracket (Male)	2
14.		Front Access Bracket (Female)	2



15.		16mm C/Sunk Screw	24
16.		Foot	4

1. Attaching Cam Pins, Dowels & Fascia Brackets

Insert all Cam Pins (9) and 5mm Dowels (10). Attach the Fascia Brackets (11/13) as shown using the 16mm screw (15). Knock the Feet (16) into the bottom of the End Panels (1/2) using a hammer.

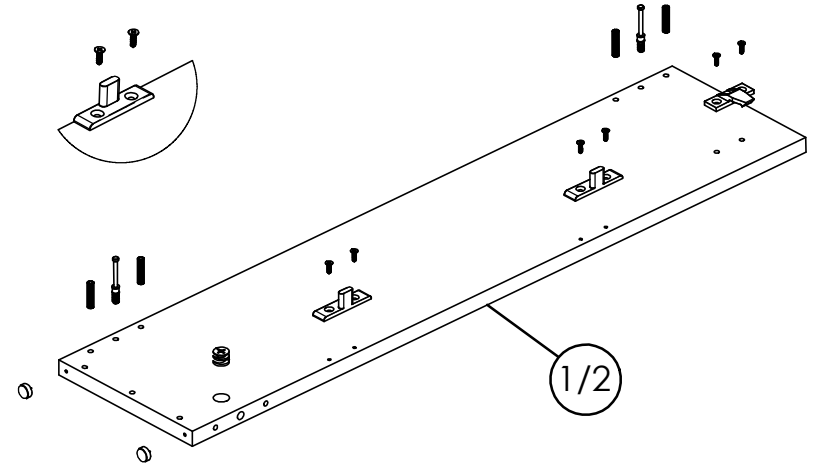

2. Inserting Cams

Insert all Cams (8). Point Cam Arrow towards the intersecting Cam hole.

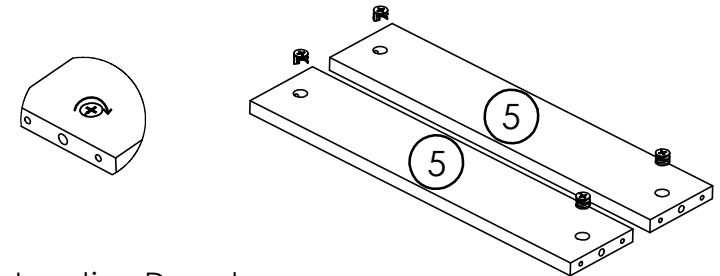

3. Inserting Dowels

Insert four of the 8mm Dowels (10) into the Top Panel (3).

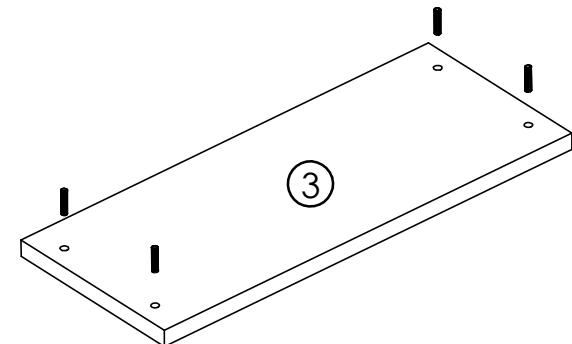

4. Assembling the Unit

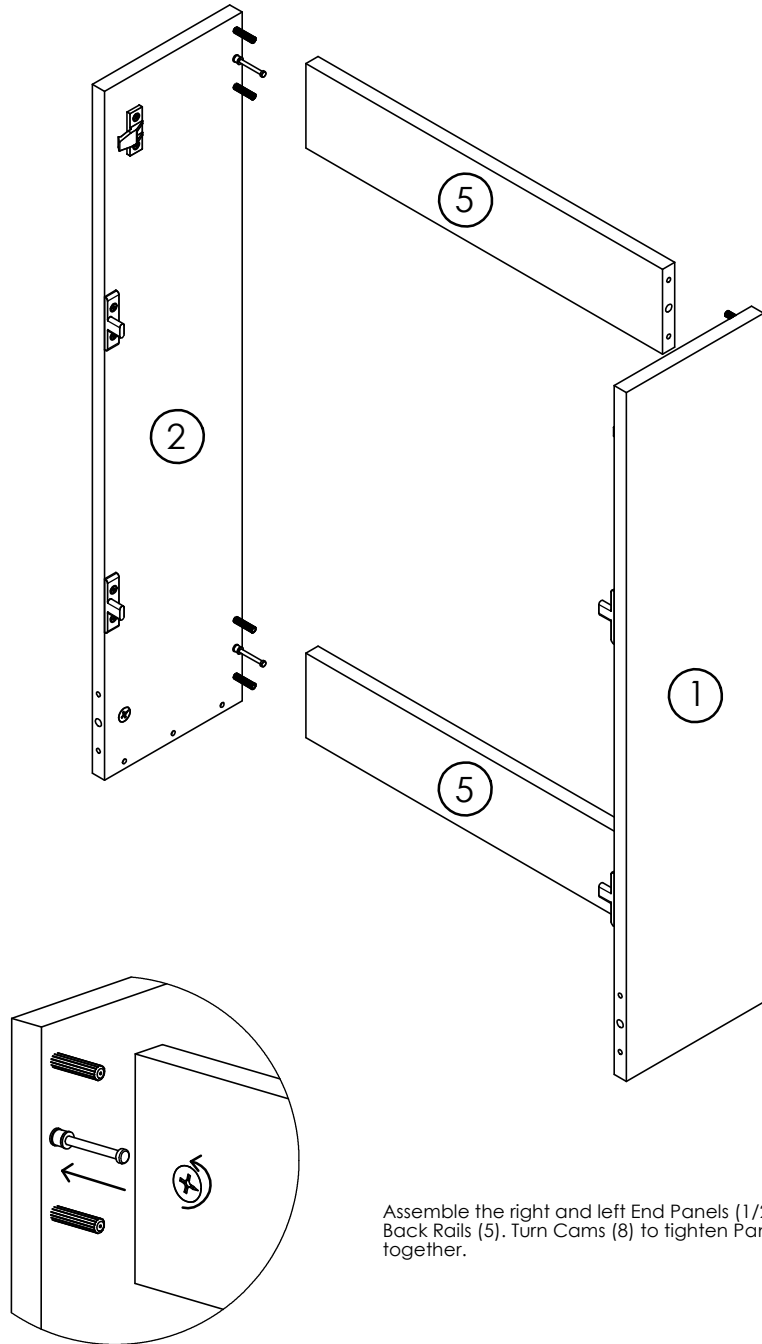

Assemble the right and left End Panels (1/2) with the Back Rails (5). Turn Cams (8) to tighten Panels together.

5. Pan Cut Out

Refer to separate instruction for cut-out.

NOTE: After cutting or drilling ensure all raw edges are sealed. (Cut-out shown is an example).

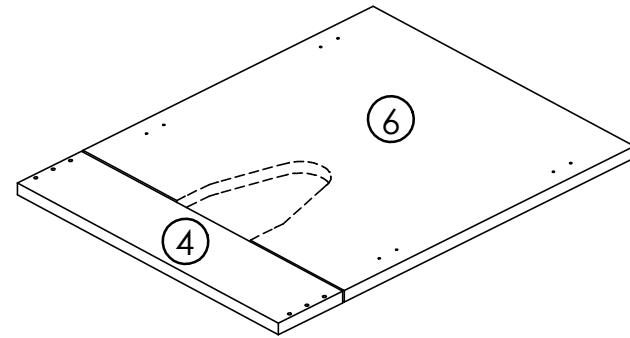

5. Fascia Attachment

Attach Fascia Brackets (12/14) with 16mm screws (15). Clip the Fascias to the unit, attaching the Bottom Fascia first. Insert the Dowels and Cam Pins into the Plinth (4). Fit the panels to the front of the Unit.

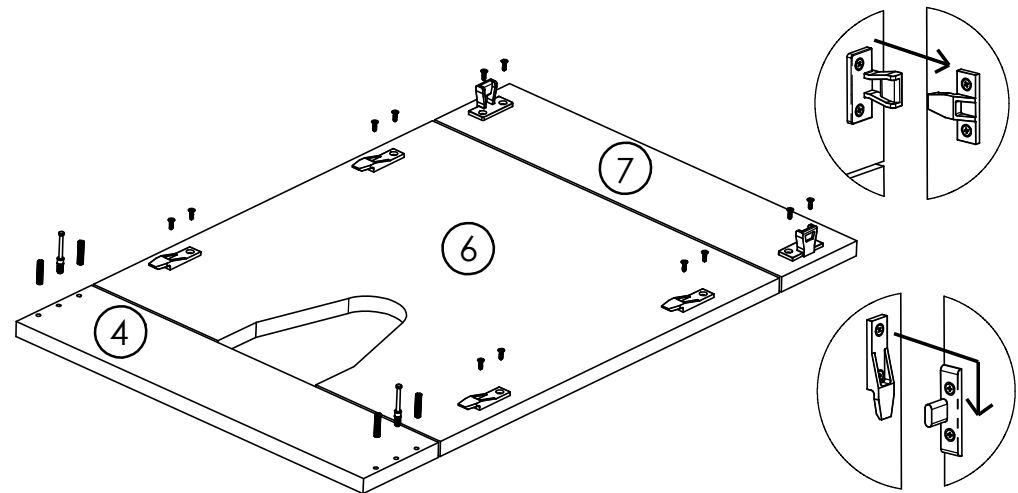

6. Top Panel

Place the Top Panel (3) on top of the unit with the dowels aligned inside.

