

PT	Instruções para uso / Manual de Instalação	2
ES	Modo de empleo / Instrucciones de montaje	3
EN	Instructions for use / assembly instructions	4
DE	Gebrauchsanleitung / Montageanleitung	5

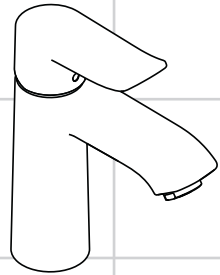

Metris 110
31084010

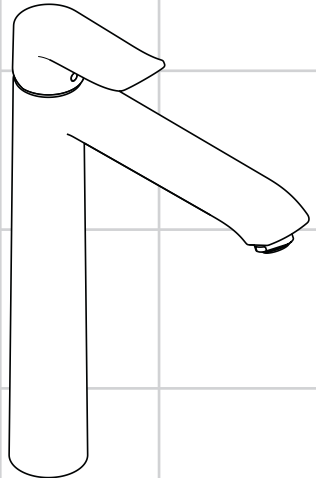

Metris 260
31082010



Avisos de segurança

- ⚠ Durante a montagem devem ser utilizadas luvas de protecção, de modo a evitar ferimentos resultantes de entalamentos e de cortes.
- ⚠ O sistema de duche só pode ser utilizado para fins de higiene pessoal.
- ⚠ Grandes diferenças entre as pressões das águas quente e fria devem ser compensadas.

Avisos de montagem

- Antes da montagem deve-se controlar o produto relativamente a danos de transporte. Após a montagem não são aceites quaisquer danos de transporte ou de superfície.
- As tubagens e a torneira têm que ser montadas, enxaguadas e verificadas de acordo com as normas em vigor.
- A prescrições de instalação válidas nos respetivos países devem ser respeitadas.
- **31082010:** Em caso de problemas com o esquentador de água ou se desejar maior débito de água, é possível retirar o EcoSmart® (limitador de caudal), situado por trás do emulsor.

Dados Técnicos

Pressão de funcionamento:	max. 1 MPa
Pressão de func. recomendada:	0,1 - 0,5 MPa
Pressão testada:	1,6 MPa
(1 MPa = 10 bar = 147 PSI)	
Temperatura da água quente:	max. 80 °C
Temp. água quente recomendada:	65 °C
Desinfecção térmica:	max. 70 °C / 4 min

Este produto foi única e exclusivamente concebido para água potável!

31082010: Misturadoras produzidas em série com EcoSmart® (limitador de caudal)

Descrição do símbolo



Não utilizar silicone que contenha ácido acético!



Afinação (ver página [11](#))

Ajuste do limitador de água quente. Em combinação com um esquentador, não é recomendável o uso de um bloqueio de água quente.

Medidas (ver página [11](#))



Caudal

(ver página [11](#))

- ① com EcoSmart®
- ② sem EcoSmart®



Peças de substituição (ver página [11](#))



Funcionamento (ver página [12](#))

A Hansgrohe recomenda a não utilização do primeiro meio litro de água, de manhã ou após longas paragens, para fins de consumo.



Limpeza

consultar a seguinte brochura.





Marca de controlo (ver página [12](#))



Montagem ver página [6](#)



Indicaciones de seguridad

-  Durante el montaje deben utilizarse guantes para evitar heridas por aplastamiento o corte.
-  La grifería solo debe ser utilizada para fines de baño, higiene y limpieza corporal.
-  Grandes diferencias de presión en servicio entre agua fría y agua caliente deben equilibrarse.

Indicaciones para el montaje

- Antes del montaje se debe examinarse el producto contra daños de transporte. Después de la instalación so se reconoce ningún daño de transporte o de superficie.
- Los conductos y la grifería deben montarse, lavarse y comprobarse según las normas vigentes.
- Es obligatorio el cumplimiento de las directrices de instalación vigentes en el país respectivo.
- **31082010:** En caso de problemas con el calentador instantáneo o cuando se desee más caudal de agua puede quitarse el EcoSmart® (limitador de caudal), situado detrás del aireador.

Datos técnicos

Presión en servicio:	max. 1 MPa
Presión recomendada en servicio:	0,1 - 0,5 MPa
Presión de prueba:	1,6 MPa
(1 MPa = 10 bar = 147 PSI)	
Temperatura del agua caliente:	max. 80 °C
Temp. recomendada del agua caliente:	65 °C
Desinfección térmica:	max. 70 °C / 4 min

El producto ha sido concebido exclusivamente para agua potable.

31082010: Grifo, desde fábrica equipado con EcoSmart® (limitador de caudal)

Descripción de símbolos



No utilizar silicona que contiene ácido acético!



Ajuste (ver página [11](#))

Ajuste del límite de agua caliente. En combinación con calentadores continuos no es recomendable utilizar un bloqueo de agua caliente.

Dimensiones (ver página [11](#))



Caudal máximo

(ver página [11](#))

① con EcoSmart®

② sin EcoSmart®



Repuestos (ver página)



Manejo (ver página [12](#))

Hansgrohe recomienda no utilizar el primer medio litro como agua potable por las mañanas o tras un largo periodo de inactividad.



Limpiar

ver el folleto adjunto.





Marca de verificación (ver página [12](#))



Montaje ver página [6](#)



Safety Notes

-  Gloves should be worn during installation to prevent crushing and cutting injuries.
-  The shower system may only be used for bathing, hygienic and body cleaning purposes.
-  The hot and cold supplies must be of equal pressures.

Installation Instructions

- Prior to installation, inspect the product for transport damages. After it has been installed, no transport or surface damage will be honoured.
- The pipes and the fixture must be installed, flushed and tested as per the applicable standards.
- The plumbing codes applicable in the respective countries must be observed.
- **31082010:** If the instantaneous water heater causes problems or if you wish to increase the water flow, the EcoSmart® (flow limiter) located behind the aerator can be removed.

Technical Data

Operating pressure:	max. 1 MPa
Recommended operating pressure:	0,1 - 0,5 MPa
Test pressure:	1,6 MPa
(1 MPa = 10 bar = 147 PSI)	
Hot water temperature:	max. 80 °C
Recommended hot water temp.:	65 °C
Thermal disinfection:	max. 70 °C / 4 min

The product is exclusively designed for drinking water!

31082010: This mixer series-produced with EcoSmart® (flow limiter)

Symbol description



Do not use silicone containing acetic acid!



Adjustment (see page [11](#))

To adjust the hot water limiter. Using a hot water limiter in combination with a continuous flow water heater is not recommended.

Dimensions (see page [11](#))



Rate of flow

(see page [11](#))

① with EcoSmart®

② without EcoSmart®



Spare parts (see page)



Operation (see page [12](#))

Hansgrohe recommends not to use as drinking water the first half liter of water drawn in the morning or after a prolonged period of non-use.



Cleaning

see enclosed brochure.



Test certificate (see page [12](#))



Assembly see page [6](#)



Sicherheitshinweise

- ⚠ Bei der Montage müssen zur Vermeidung von Quetsch- und Schnittverletzungen Handschuhe getragen werden.
- ⚠ Das Produkt darf nur zu Bade-, Hygiene- und Körperreinigungszwecken eingesetzt werden.
- ⚠ Große Druckunterschiede zwischen den Kalt- und Warmwasseranschlüssen müssen ausgeglichen werden.

Montagehinweise

- Vor der Montage muss das Produkt auf Transportschäden untersucht werden. Nach dem Einbau werden keine Transport- oder Oberflächenschäden anerkannt.
- Die Leitungen und die Armatur müssen nach den gültigen Normen montiert, gespült und geprüft werden.
- Die in den Ländern jeweils gültigen Installationsrichtlinien sind einzuhalten.
- **31082010:** Bei Problemen mit dem Durchlauferhitzer oder wenn mehr Wasserdurchsatz gewünscht wird, kann der EcoSmart® (Durchflussbegrenzer), der hinter dem Luftsprudler sitzt, entfernt werden.

Technische Daten

Betriebsdruck:	max. 1 MPa
Empfohlener Betriebsdruck:	0,1 - 0,5 MPa
Prüfdruck:	1,6 MPa
(1 MPa = 10 bar = 147 PSI)	
Heißwassertemperatur:	max. 80 °C
Empfohlene Heißwassertemperatur:	65 °C
Thermische Desinfektion:	max. 70 °C / 4 min

Das Produkt ist ausschließlich für Trinkwasser konzipiert!

31082010: Armatur serienmäßig mit EcoSmart® (Durchflussbegrenzer)

Symbolerklärung



Kein essigsäurehaltiges Silikon verwenden!



Justierung (siehe Seite [11](#))

Einstellen der Warmwasserbegrenzung. In Verbindung mit Durchlauferhitzern ist eine Warmwassersperre nicht zu empfehlen.

Maße (siehe Seite [11](#))

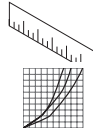

Durchflussleistung

(siehe Seite [11](#))

- ① mit EcoSmart®
- ② ohne EcoSmart®



Serviceteile (siehe Seite [12](#))



Bedienung (siehe Seite [12](#))

Hansgrohe empfiehlt, morgens oder nach längeren Stagnationszeiten den ersten halben Liter nicht als Trinkwasser zu verwenden.



Reinigung

siehe beiliegende Broschüre.



Prüfzeichen (siehe Seite [12](#))



Montage siehe Seite [6](#)

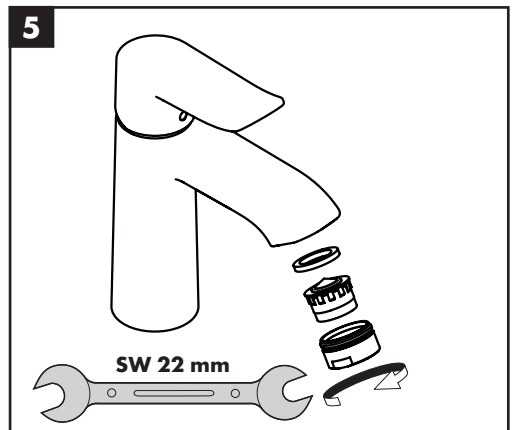
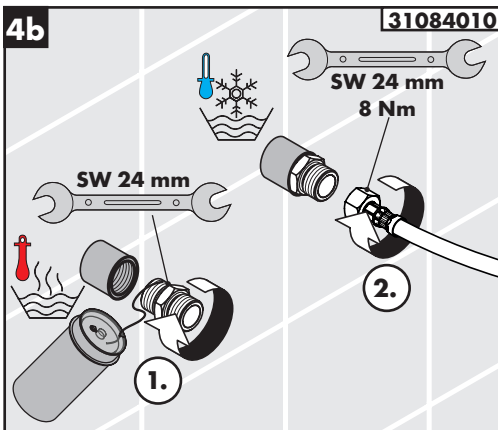
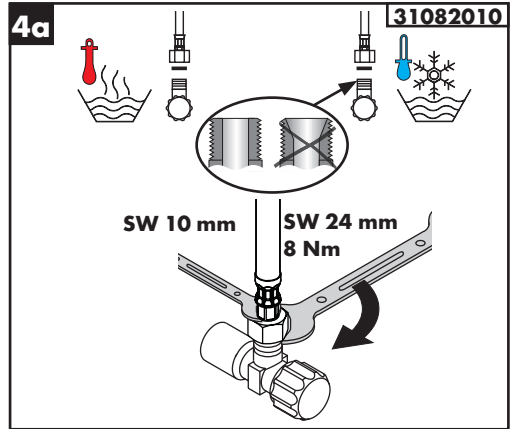
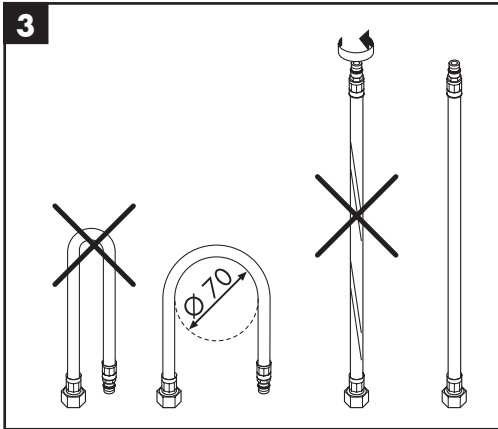
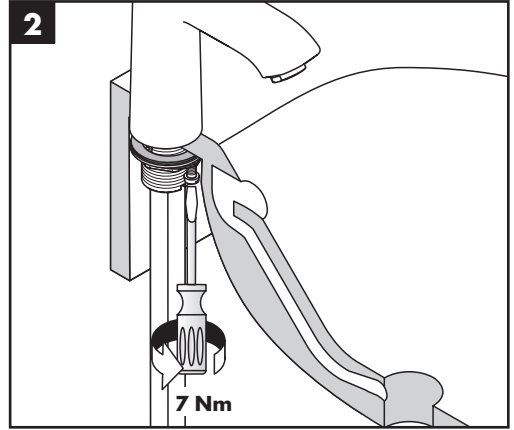
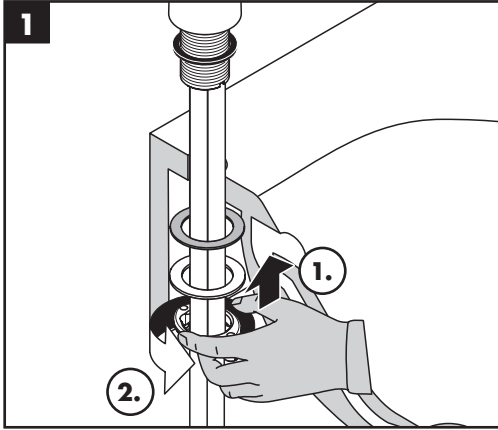

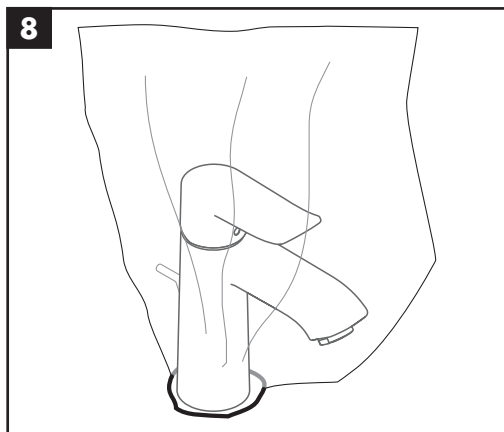
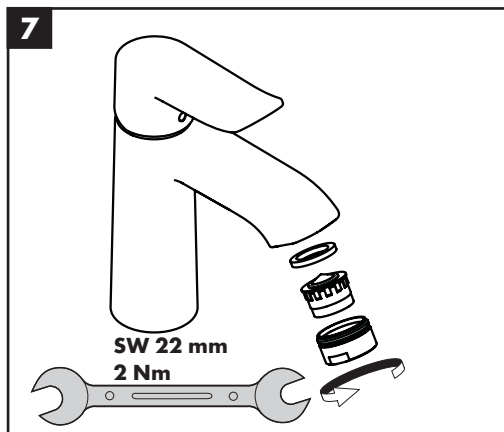
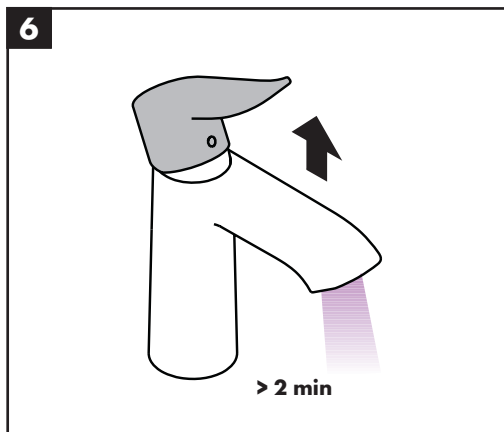

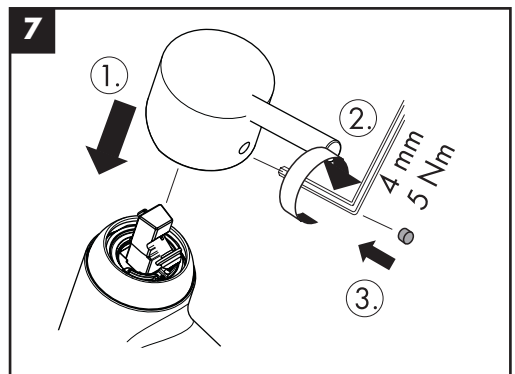
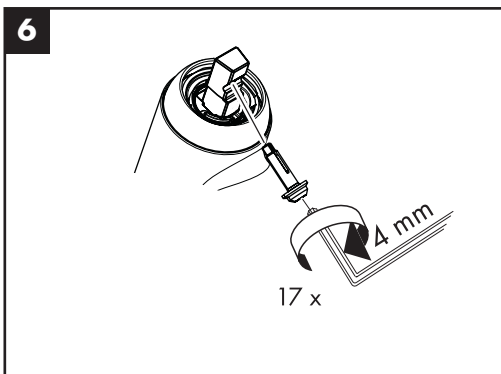
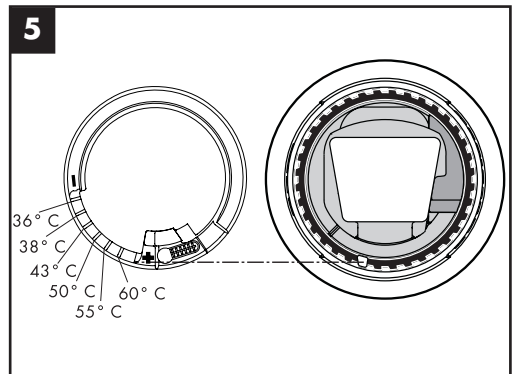
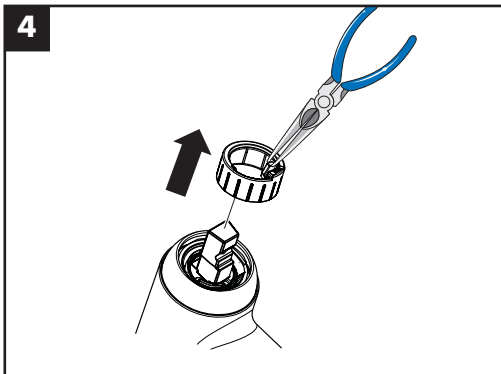
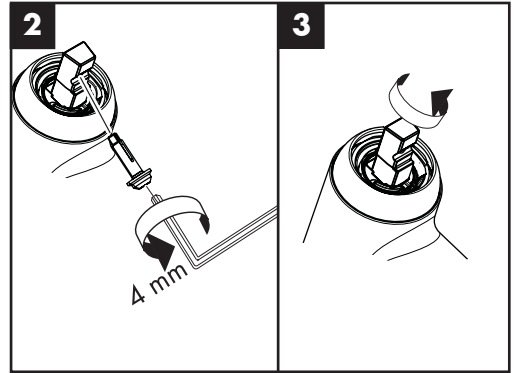
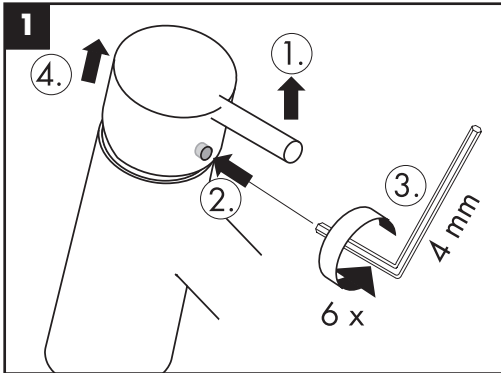



Metris
31082010

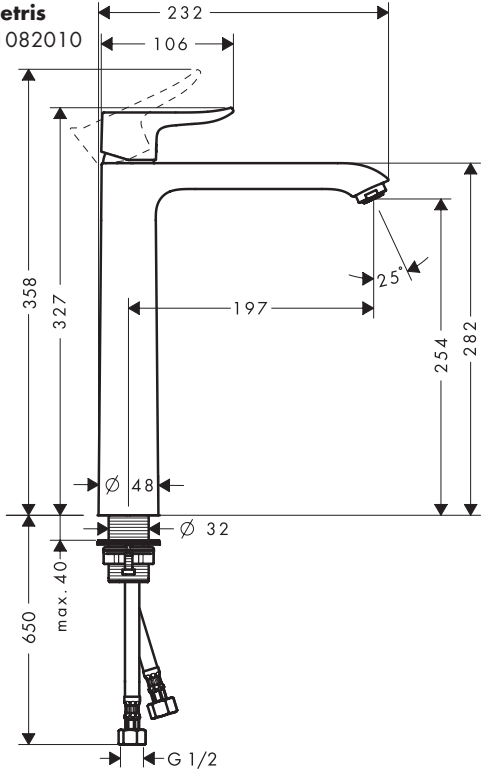

Metris
31084010

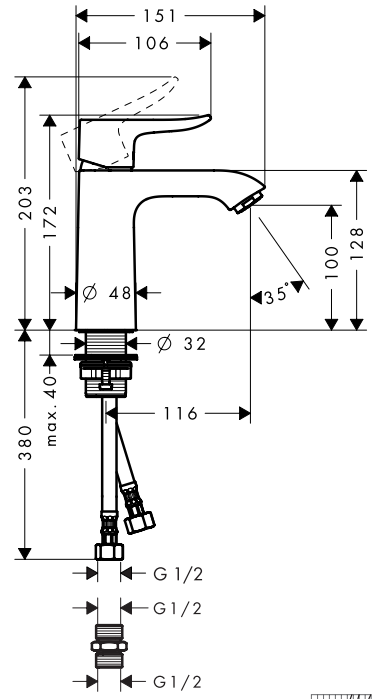

Metris
31082010

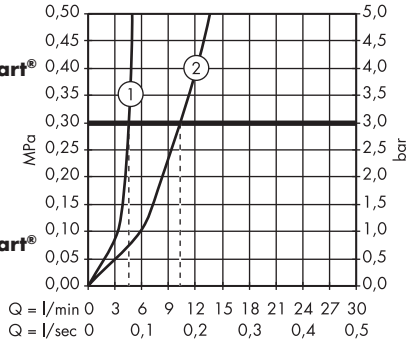
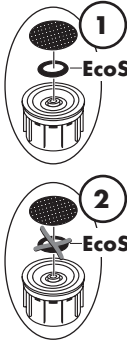

Metris
31084010

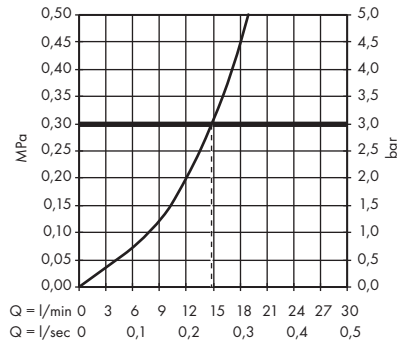



Metris 260
31082010

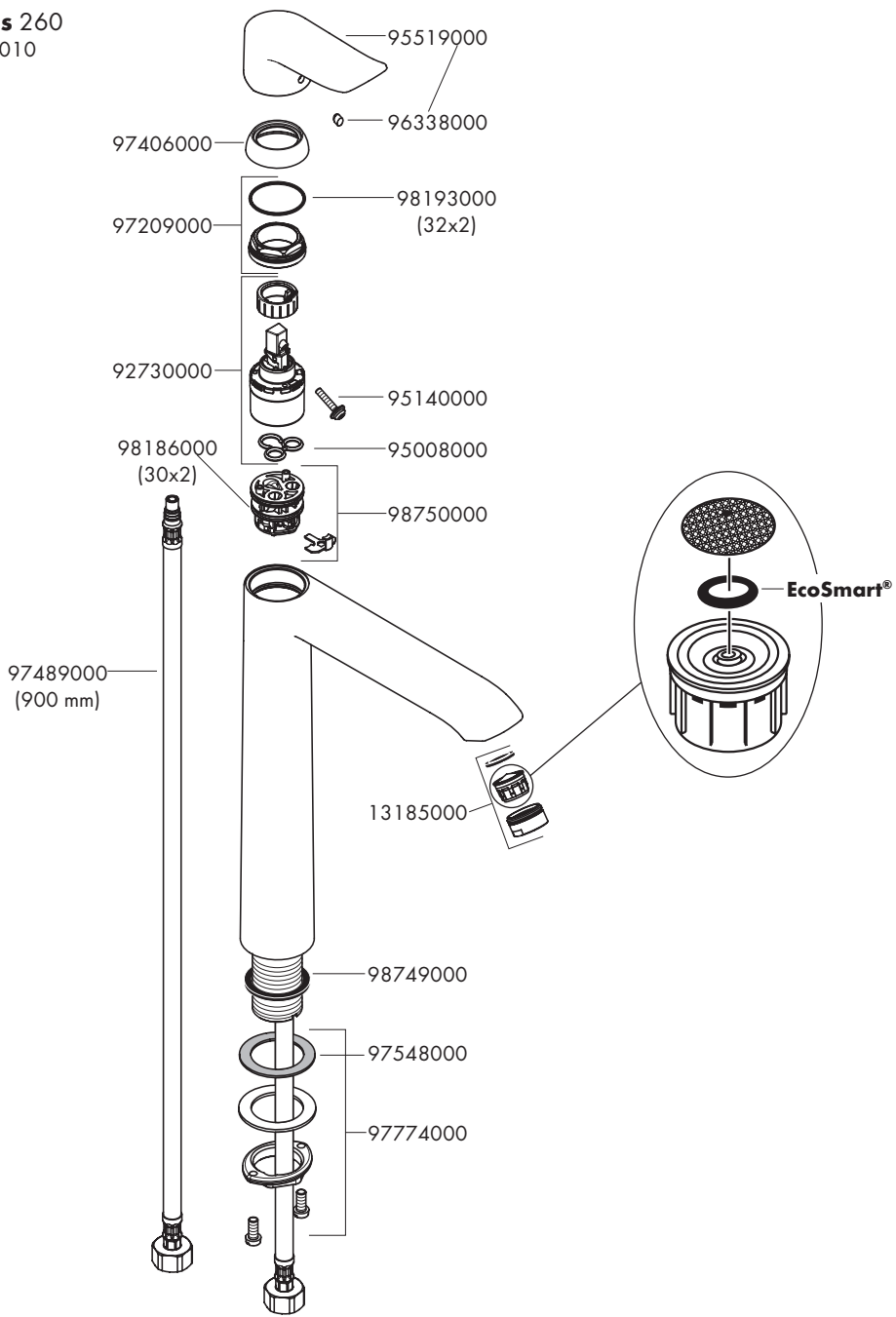



Metris 110
31084010

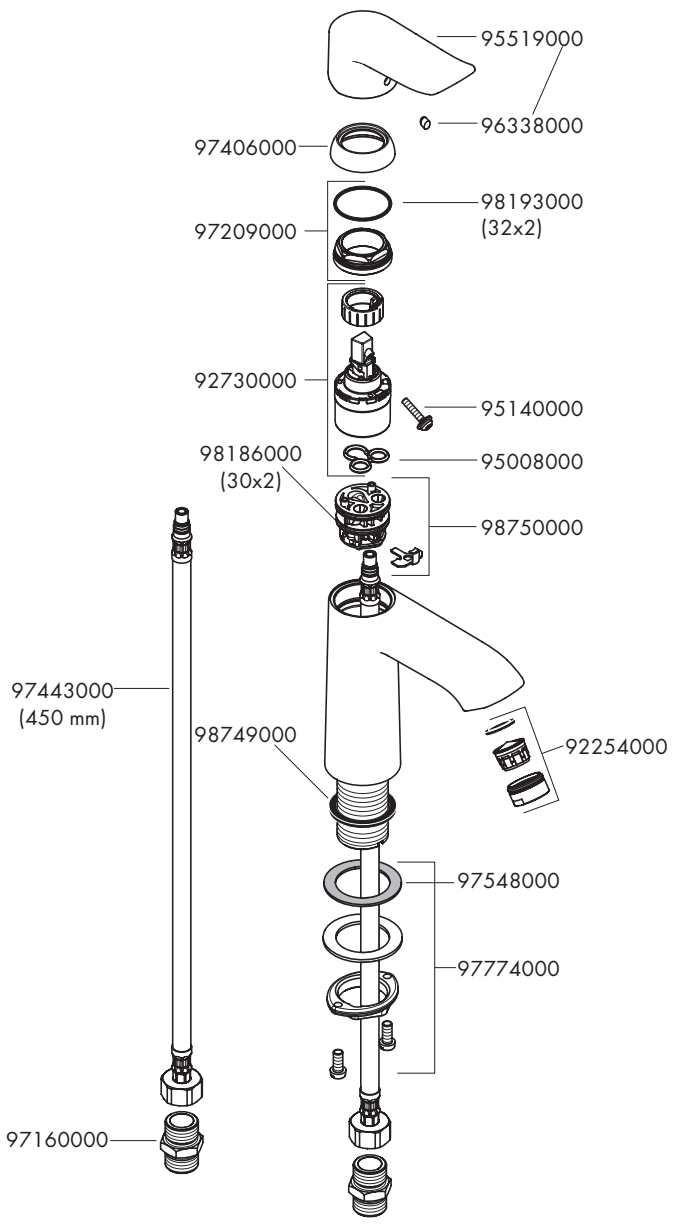

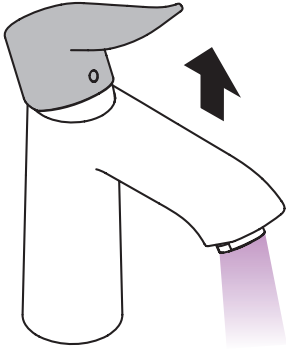

abrir / abierto / open / öffnen

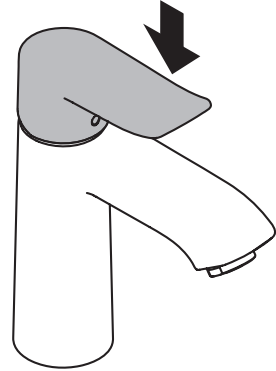

fechar / cerrar / close / schließen

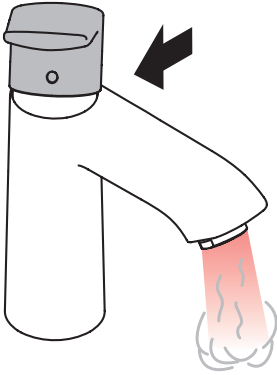

quente / caliente / hot / warm

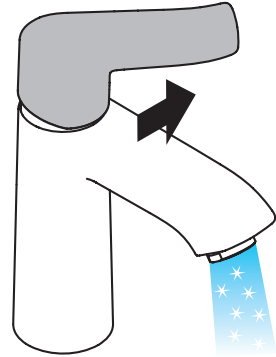

fria / frío / cold / kalt



P-IX

DVGW

SVGW

ACS

WRAS

ETA

31082010

31084010

X

DE /Gebrauchsanleitung / Montageanleitung

EN /Instructions for use / assembly instructions

2

4

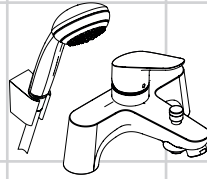

Focus
31521000

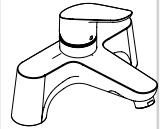

Focus
31523000

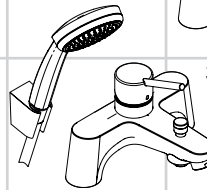

Talis
31426000

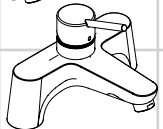

Talis
31427000

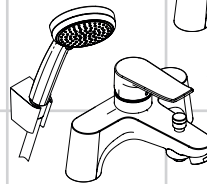

Metris
31422000

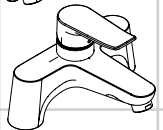

Metris
31423000

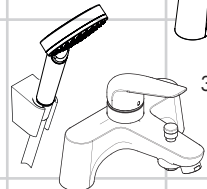

Novus
71044000

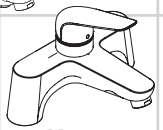

Novus
71043000



Sicherheitshinweise

- Bei der Montage müssen zur Vermeidung von Quetsch- und Schnittverletzungen Handschuhe getragen werden.
- Das Produkt darf nur zu Bade-, Hygiene- und Körperreinigungszwecken eingesetzt werden.
- Große Druckunterschiede zwischen den Kalt- und Warmwasseranschlüssen müssen ausgeglichen werden.

Montagehinweise

- Vor der Montage muss das Produkt auf Transportschäden untersucht werden. Nach dem Einbau werden keine Transport- oder Oberflächenschäden anerkannt.
- Die Leitungen und die Armatur müssen nach den gültigen Normen montiert, gespült und geprüft werden.
- Die in den Ländern jeweils gültigen Installationsrichtlinien sind einzuhalten.
- Für Wartungsarbeiten muss unbedingt eine Revisionsöffnung vorgesehen werden! Der vormontierte Filtereinsatz muss verwendet werden, um den Normdurchfluss der Handbrause zu gewährleisten und um Schmutzeinspülungen aus dem Leitungsnetz zu vermeiden. Schmutzeinspülungen können die Funktion beeinträchtigen und/oder zu Beschädigungen an Funktionsteilen der Handbrause führen, für hieraus ergebende Schäden haftet Hansgrohe nicht
- Die der Brause beige packte Siebdichtung muss eingebaut werden, um Schmutzeinspülungen aus dem Leitungsnetz zu vermeiden. Schmutzeinspülungen können die Funktion beeinträchtigen und/oder zu Beschädigungen an Funktionsteilen der Brause führen, für hieraus ergebende Schäden haftet Hansgrohe nicht.

Technische Daten

Betriebsdruck:	max. 1 MPa
Empfohlener Betriebsdruck:	0,1 - 0,5 MPa
Prüfdruck:	1,6 MPa
(1 MPa = 10 bar = 147 PSI)	
Heißwassertemperatur:	max. 70 °C
Empfohlene Heißwassertemperatur:	65 °C
Thermische Desinfektion:	max. 70 °C/4 min

Das Produkt ist ausschließlich für Trinkwasser konzipiert!

Symbolbeschreibung



Kein essigsäurehaltiges Silikon verwenden!



Justierung (siehe Seite [14](#))

Einstellen der Warmwasserbegrenzung. In Verbindung mit Durchlauferhitzern ist eine Warmwassersperre nicht zu empfehlen.



Masse
(siehe Seite [14](#))



Durchflussdiagramm
(siehe Seite [14](#))

- Abgang Wanne
- Abgang Brause



Bedienung
(siehe Seite [15](#))



Reinigung
(siehe Seite [19](#))



Serviceteile
(siehe Seite [16](#))



Wartung (siehe Seite [16](#))

Rückflussverhinderer müssen gemäß DIN EN 1717 regelmäßig in Übereinstimmung mit nationalen oder regionalen Bestimmungen auf ihre Funktion geprüft werden (mindestens einmal jährlich).



Prüfzeichen
(siehe Seite [20](#))



Montage siehe Seite [6](#)



Störung	Ursache	Abhilfe
Wenig Wasser	<ul style="list-style-type: none">- Rückflussverhinderer sitzt fest- Filtereinsatz der Brause verschmutzt- Siebdichtung der Brause verschmutzt	<ul style="list-style-type: none">- Rückflussverhinderer austauschen- Filtereinsatz zwischen Brause und Schlauch reinigen- Siebdichtung zwischen Brause und Schlauch reinigen
Armatur schwergängig	<ul style="list-style-type: none">- Kartusche defekt, verkalkt	<ul style="list-style-type: none">- Kartusche austauschen
Armatur tropft	<ul style="list-style-type: none">- Kartusche defekt	<ul style="list-style-type: none">- Kartusche austauschen
Durchlauferhitzer schaltet nicht ein	<ul style="list-style-type: none">- Rückflussverhinderer sitzt fest	<ul style="list-style-type: none">- Rückflussverhinderer austauschen
Zu niedrige Warmwassertemperatur	<ul style="list-style-type: none">- Warmwasserbegrenzung falsch eingestellt	<ul style="list-style-type: none">- Warmwasserbegrenzung einstellen



Safety Notes

- △ Gloves should be worn during installation to prevent crushing and cutting injuries.
- △ The product may only be used for bathing, hygienic and body cleaning purposes.
- △ The hot and cold supplies must be of equal pressures.

Installation Instructions

- Prior to installation, inspect the product for transport damages. After it has been installed, no transport or surface damage will be honoured.
- The pipes and the fixture must be installed, flushed and tested as per the applicable standards.
- The plumbing codes applicable in the respective countries must be observed.
- There must be an access door for maintenance. The premounted filter insert must be used to ensure a normal flow of the shower and to prevent dirt from entering through the pipes. Dirt entering can affect the function and/or lead to damages to the shower. Hansgrohe will not be held liable for this type of damage.
- The mesh washer must be insert to protect the shower against incoming dirt by pipework. Incoming dirt leads to defects or/and can damage parts of the shower; such caused faults voids all liability and guarantee claims.

Technical Data

Operating pressure:	max. 1 MPa
Recommended operating pressure:	0,1 - 0,5 MPa
Test pressure:	1,6 MPa
(1 MPa = 10 bar = 147 PSI)	
Hot water temperature:	max. 70°C
Recommended hot water temp.:	65°C
Thermal disinfection:	max. 70°C / 4 min

The product is exclusively designed for drinking water!

Symbol description



Do not use silicone containing acetic acid!



Adjustment (see page [14](#))

To adjust the hot water limiter. Using a hot water limiter in combination with a continuous flow water heater is not recommended.



Dimensions

(see page [8](#))



Flow diagram

(see page [12](#))

- ① Tub outlet
- ② Shower outlet



Operation

(see page [15](#))



Cleaning

(see page [19](#))



Spare parts

(see page [16](#))



Maintenance (see page [18](#))

The check valves must be checked regularly according to DIN EN 1717 in accordance with national or regional regulations (at least once a year).



Test certificate

(see page [20](#))





Fault	Cause	Remedy
Insufficient water	<ul style="list-style-type: none">- check valve hasn't moved back- filter insert shower dirty	<ul style="list-style-type: none">- Exchange check valves- Clean filter insert between shower and hose
	<ul style="list-style-type: none">- Shower filter seal dirty	<ul style="list-style-type: none">- Clean filter seal between shower and hose
Mixer stiff	<ul style="list-style-type: none">- Cartridge defective, calcified	<ul style="list-style-type: none">- Exchange cartridge
Mixer dripping	<ul style="list-style-type: none">- Cartridge defective	<ul style="list-style-type: none">- Kartusche austauschen
Instantaneous heater didn't work	<ul style="list-style-type: none">- check valve hasn't moved back	<ul style="list-style-type: none">- Exchange check valves
Hot water temperature too low	<ul style="list-style-type: none">- Hot water limiter incorrectly set	<ul style="list-style-type: none">- Set hot water limiter

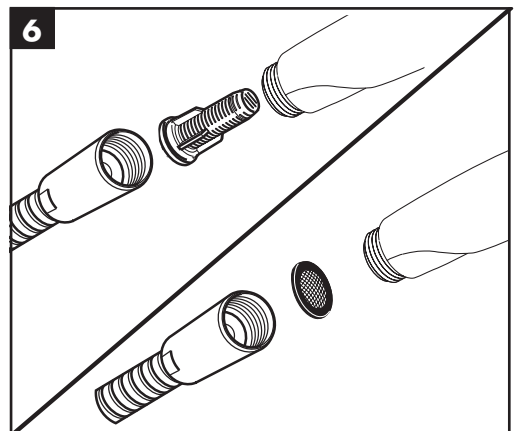
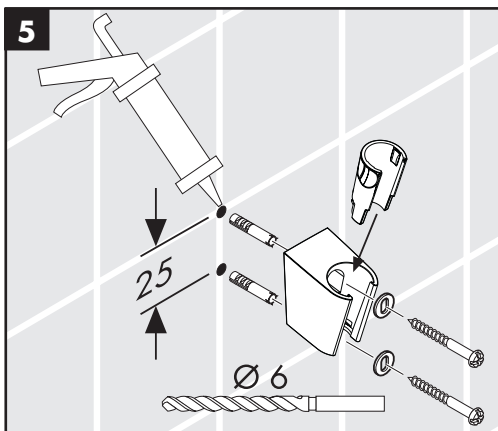
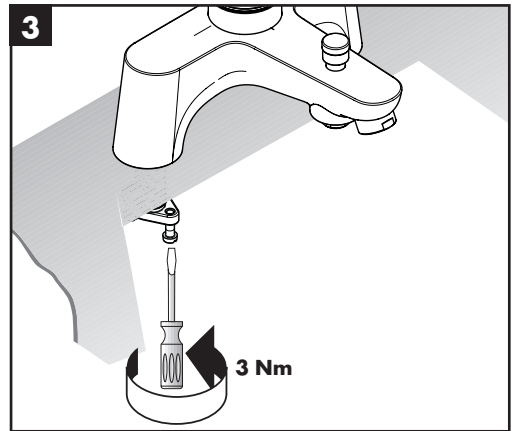
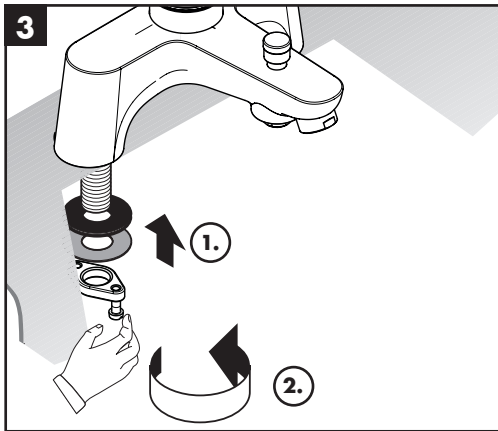
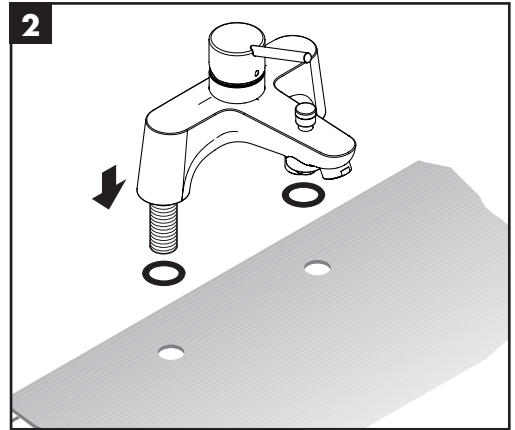
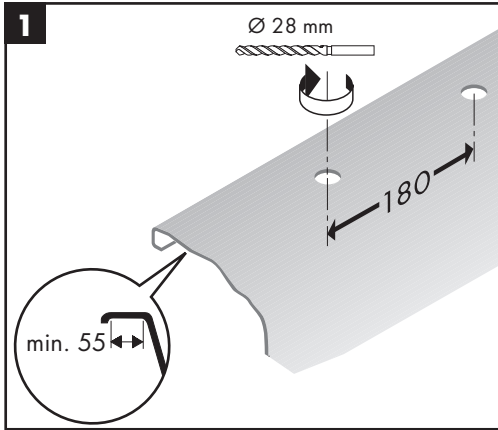

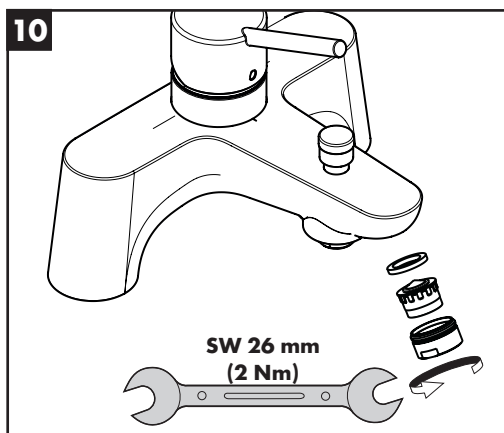
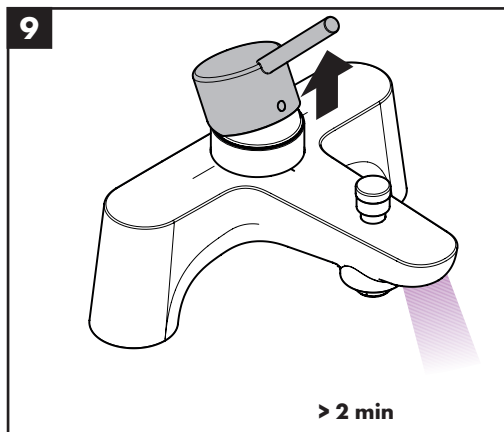
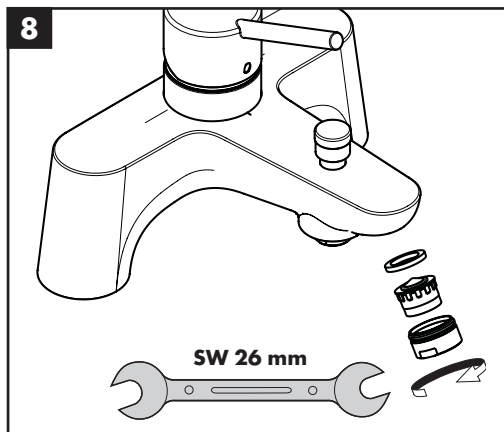
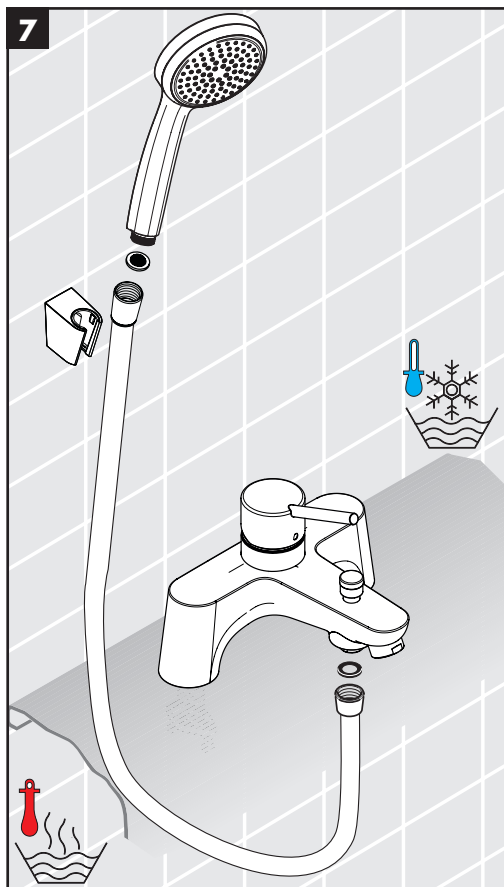



Focus
31521000

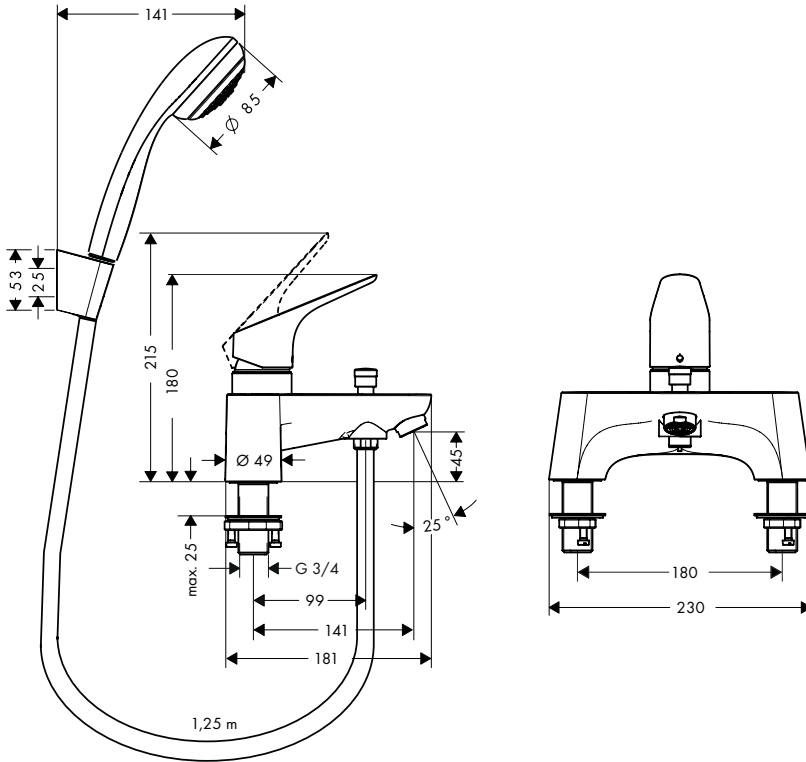

Focus
31523000

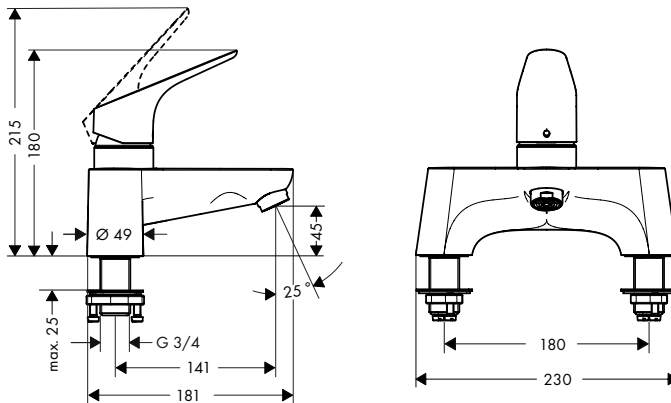

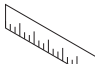

Talis
31426000

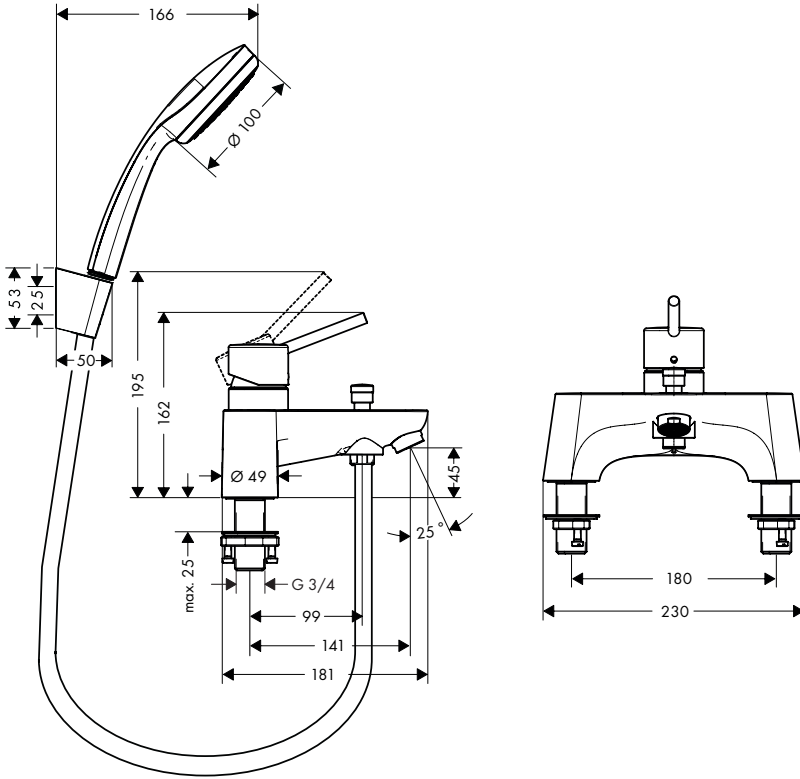

Talis
31427000

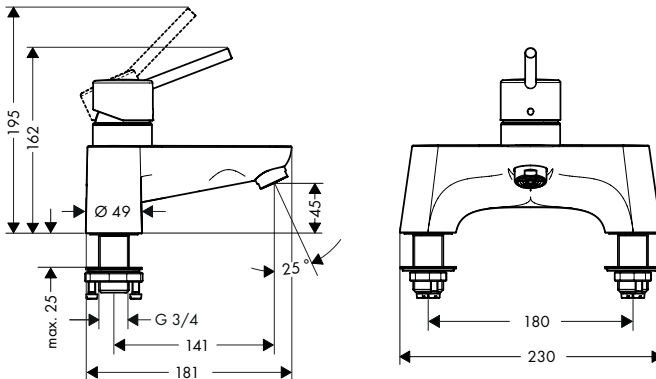



Metris
31422000

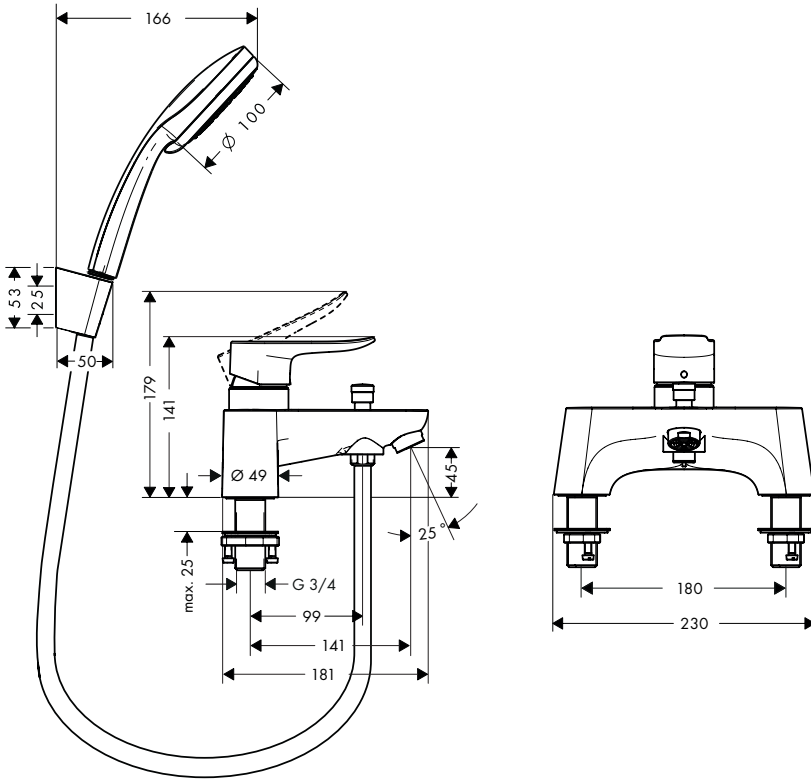

Metris
31423000

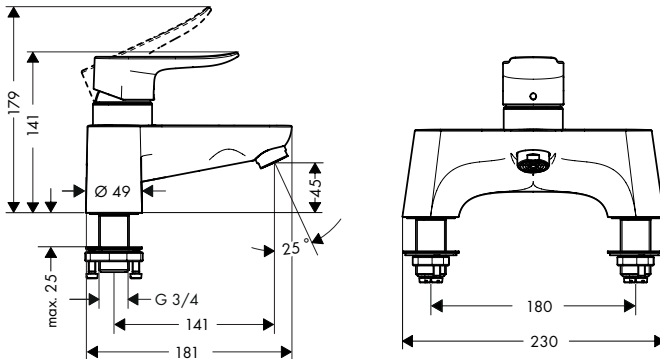

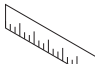

Novus
71044000

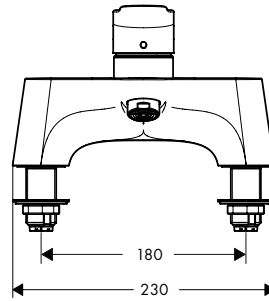
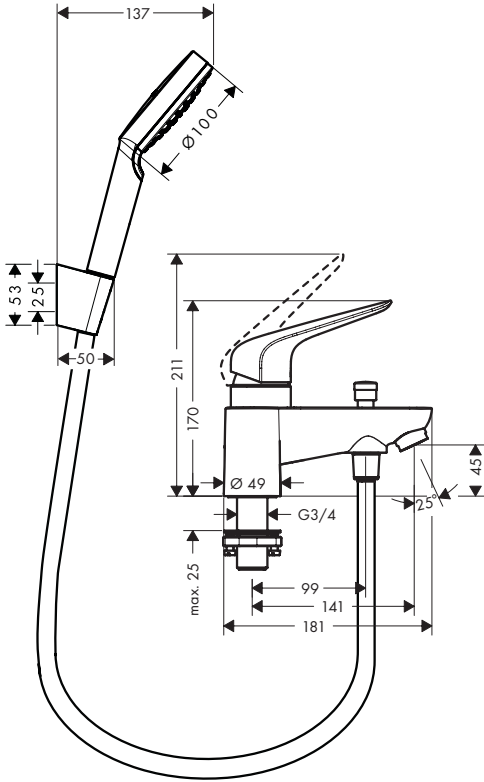

Novus
71043000

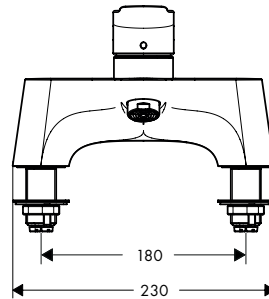
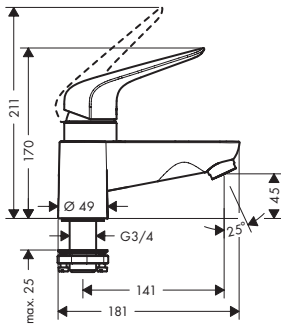



Focus

31521000/31523000

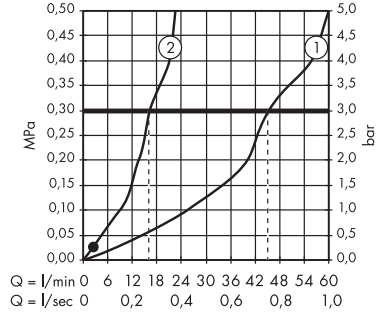
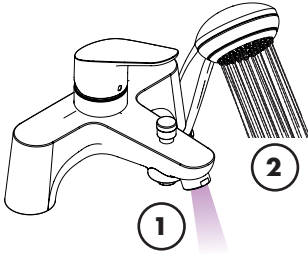

Talis

31426000/31427000

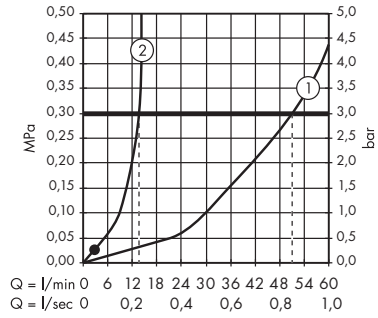
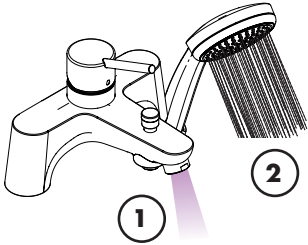

Metris

31422000/31423000

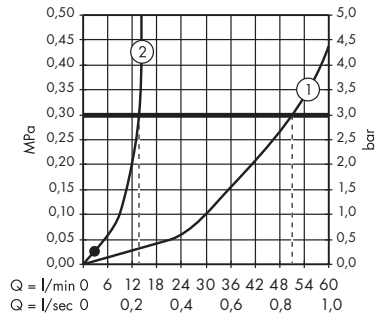



Novus
71043000/71044000

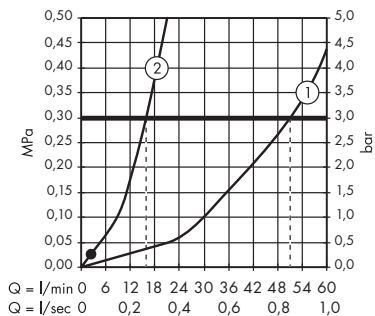
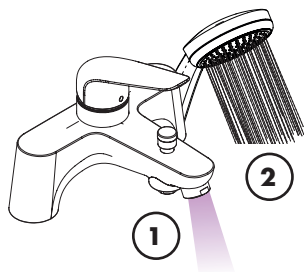

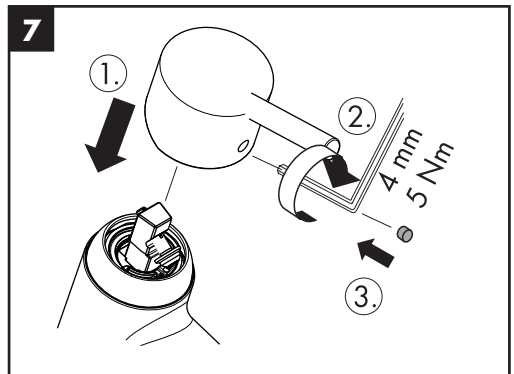
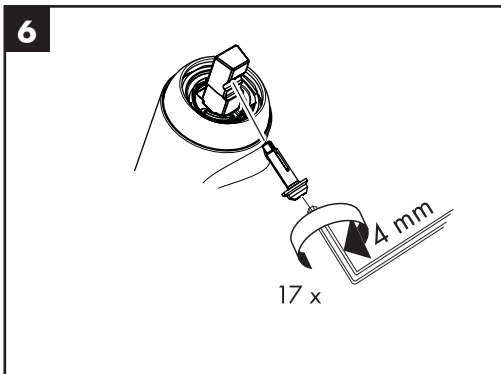
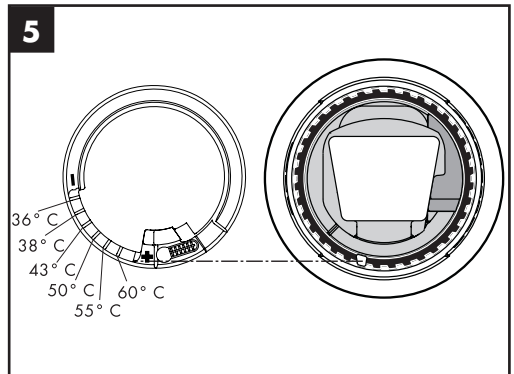
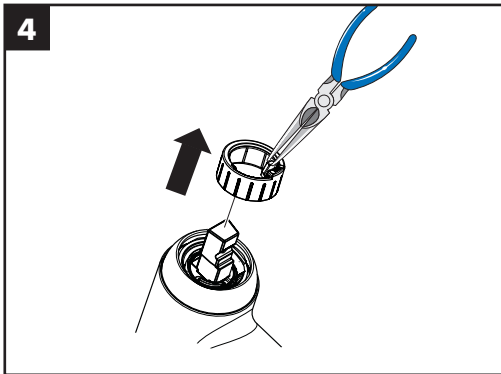
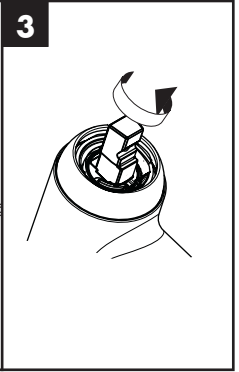
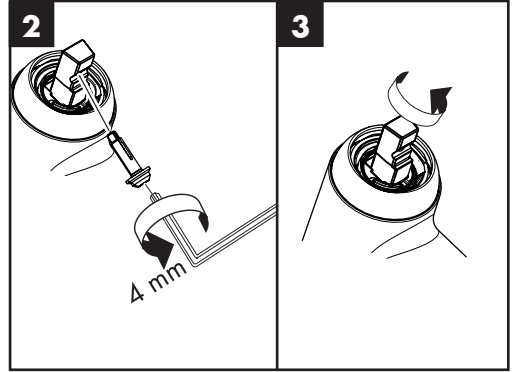
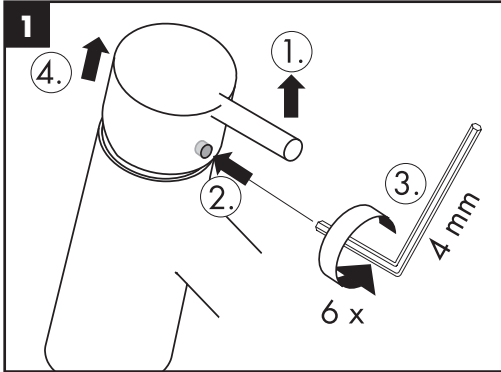
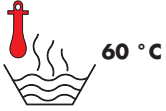

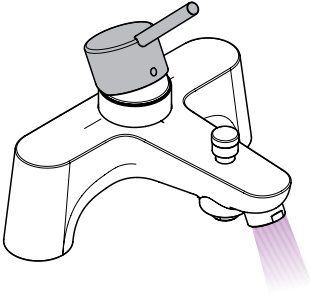

öffnen / open

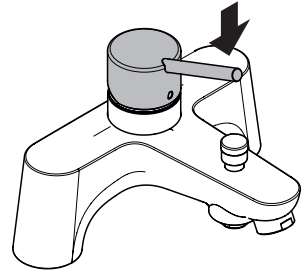

schließen / close

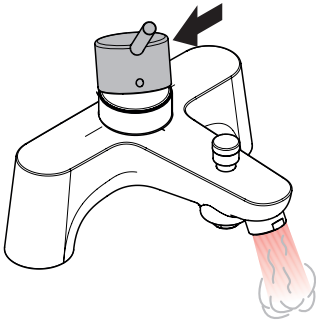

warm / hot

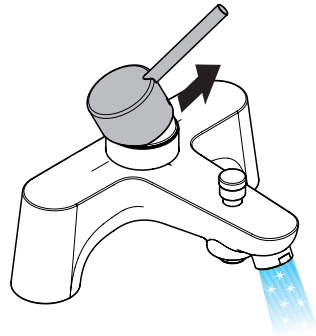

kalt / cold

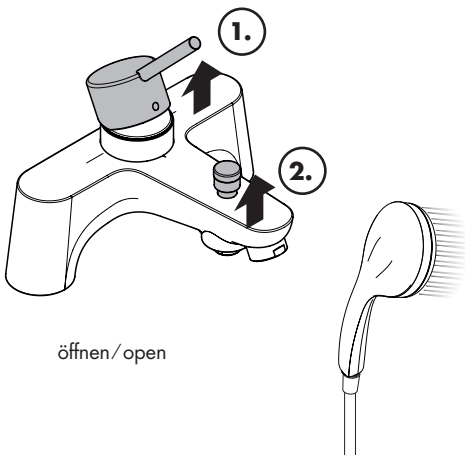

öffnen / open

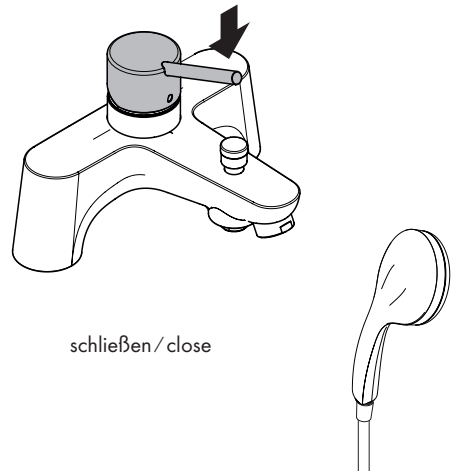

schließen / close



Focus
31521000

Talis
31426000

Metris
31422000

Novus
71044000

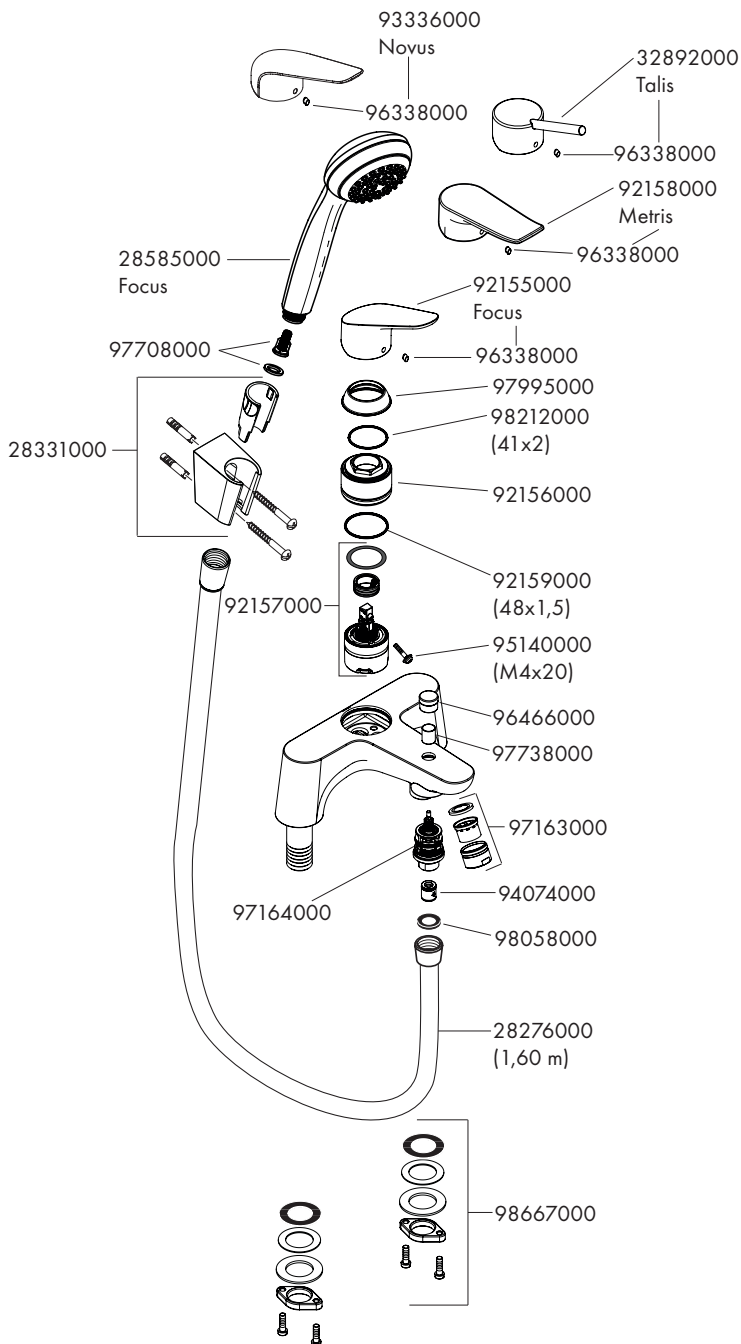
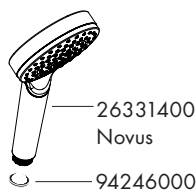



Focus
31523000

Talis
31427000

Metris
31423000

Novus
71043000

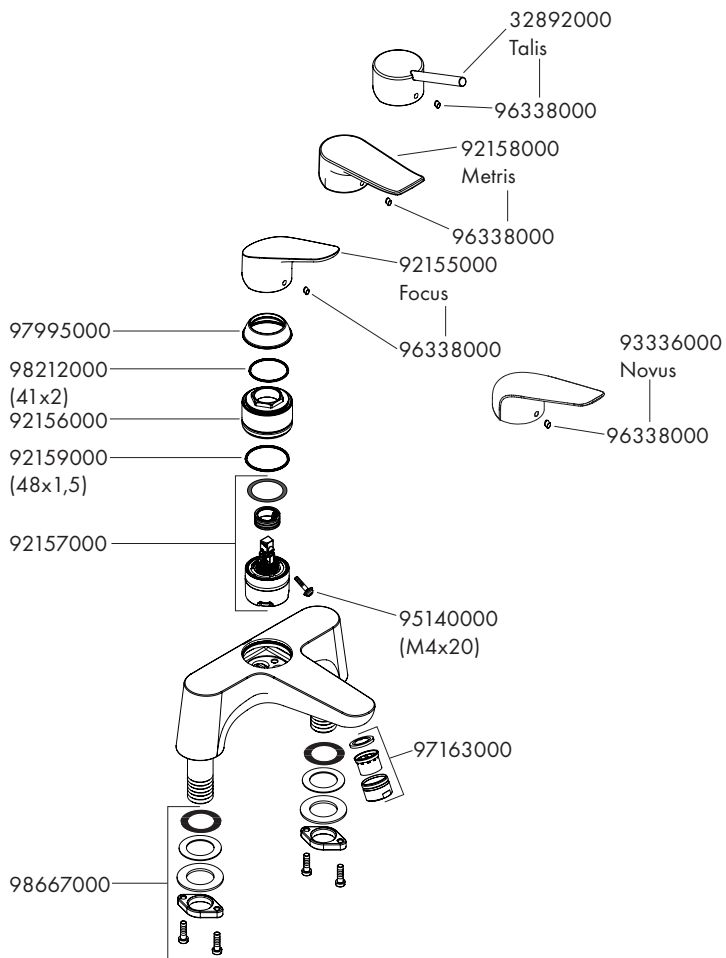

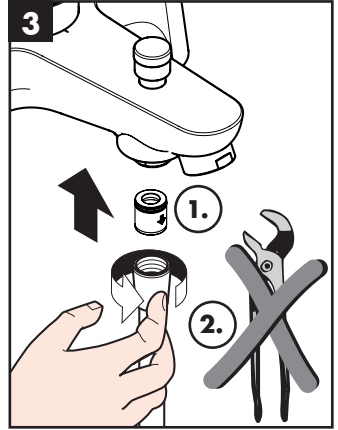
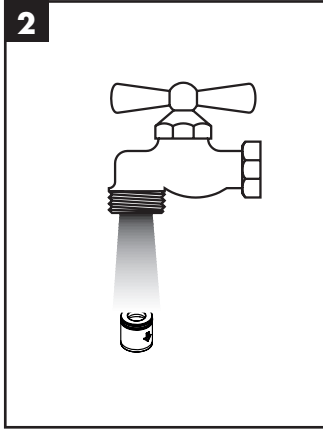
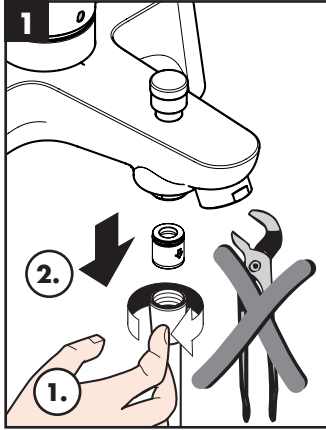

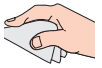

DE Reinigungsempfehlung / Garantie / Kontakt

EN Cleaning recommendation / Warranty / Contact



[www.hansgrohe.com/
cleaning-recommendation](http://www.hansgrohe.com/cleaning-recommendation)

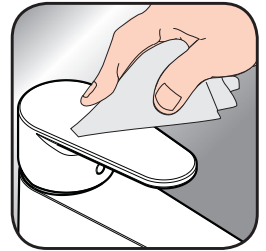

[www.hansgrohe.com/
cleaning-recommendation](http://www.hansgrohe.com/cleaning-recommendation)



[www.hansgrohe.com/
cleaning-recommendation](http://www.hansgrohe.com/cleaning-recommendation)



[www.hansgrohe.com/
cleaning-recommendation](http://www.hansgrohe.com/cleaning-recommendation)



P-IX

DVGW SVGW WRAS KIWA ACS

ETA



GODKENDT
TIL DRIKKEVAND



31521XXX

31523XXX

31426XXX

31427XXX

31422XXX

31423XXX

71044XXX

X

71043XXX

X